

**2008
Mazda3 MAZDASPEED3
Mazda5
Mazda MX-5
Mazda6
Mazda CX-7
Mazda RX-8
Mazda CX-9**

Service Highlights

FOREWORD

This manual explains components, system operations and functions for the Mazda3, MAZDASPEED3, Mazda5, Mazda MX-5, Mazda6, Mazda CX-7, Mazda RX-8, Mazda CX-9.

For proper repair and maintenance, a thorough familiarization with this manual is important, and it should always be kept in a handy place for quick and easy reference.

All the contents of this manual, including drawings and specifications, are the latest available at the time of printing. As modifications affecting repair or maintenance occur, relevant information supplementary to this volume will be made available at Mazda dealers. This manual should be kept up-to-date.

Mazda Motor Corporation reserves the right to alter the specifications and contents of this manual without obligation or advance notice.

All rights reserved. No part of this book may be reproduced or used in any form or by any means, electronic or mechanical—including photocopying and recording and the use of any kind of information storage and retrieval system—without permission in writing.

**Mazda Motor Corporation
HIROSHIMA, JAPAN**

APPLICATION:

This manual is applicable to vehicles beginning with the Vehicle Identification Numbers (VIN), and related materials shown on the following page.

**Mazda3
MAZDASPEED3**

Mazda5

Mazda MX-5

Mazda6

Mazda CX-7

Mazda RX-8

Mazda CX-9

© 2007 Mazda Motor Corporation
PRINTED IN U.S.A., SEPTEMBER 2007
Form No. 3431-1U-07I
Part No. 9999-95-010F-08

Mazda MX-5

CONTENTS

TITLE	SECTION
ENGINE	01

ENGINE

01

SECTION

OUTLINE[LF]01-00
ON-BOARD DIAGNOSTIC
[LF]01-02

INTAKE-AIR SYSTEM[LF]. . . . 01-13
CONTROL SYSTEM[LF] 01-40

01-00 OUTLINE [LF]

ENGINE ABBREVIATIONS [LF]01-00-1
ENGINE FEATURES [LF].01-00-1
 On-board Diagnostic01-00-1
 Intake-air System01-00-1

Control System01-00-1
ENGINE SPECIFICATIONS [LF].01-00-2
 Specification01-00-2

ENGINE ABBREVIATIONS [LF]

id0100e1100100

ABDC	After Bottom Dead Center
ABS	Antilock Brake System
AT	Automatic Transmission
ATDC	After Top Dead Center
BBDC	Before Bottom Dead Center
BTDC	Before Top Dead Center
CAN	Controller Area Network
CCM	Comprehensive Component Monitor
CM	Control Module
DC	Drive Cycle
DSC	Dynamic Stability Control
EX	Exhaust
HU	Hydraulic Unit
IN	Intake
KOEO	Key On Engine Off
KOER	Key On Engine Running
MT	Manual Transmission
PID	Parameter Identification
RAM	Random Access Memory

ENGINE FEATURES [LF]

id0100e1100200

On-board Diagnostic

To meet OBD-II regulations	<ul style="list-style-type: none">• Diagnostic monitoring system test results changed
Improved serviceability	<ul style="list-style-type: none">• DTC changed• PID/DATA monitor function changed• Simulation test function changed

Intake-air System

Improved emission gas purification	<ul style="list-style-type: none">• Variable tumble system adopted (AT)
------------------------------------	---

Control System

Improved emission gas purification	<ul style="list-style-type: none">• Variable tumble control adopted (AT)
------------------------------------	--

OUTLINE [LF]

ENGINE SPECIFICATIONS [LF]

id0100e1100300

Specification

Item		Specification	
		2008MY	2007MY
		LF (2.0L)	LF (2.0L)
MECHANICAL			
Type		DOHC-16 valves in-line, 4-cylinder	←
Combustion chamber		Pentroof	←
Displacement (ml {cc, cu in})		1,999 {1,999, 122.0}	←
Bore × stroke (mm {in})		87.5 × 83.1 {3.44 × 3.27}	←
Compression ratio		10:8	←
Compression pressure (kPa {kgf/cm ² , psi} [rpm])		1,720 {17.54, 249.5} [300]	←
Valve timing	IN	Open BTDC (°)	0—30
		Close ABDC (°)	32—62
	EX	Open BBDC (°)	42
		Close ATDC (°)	5
Valve clearance (mm {in})	IN	0.22—0.28 {0.0087—0.011} [Engine cold]	←
	EX	0.27—0.33 {0.0107—0.0129} [Engine cold]	←
LUBRICATION SYSTEM			
Type		Force-fed type	←
Oil pressure (reference value) [oil temperature: 100°C {212°F}] (kPa {kgf/cm ² , psi} [rpm])		337—591 {3.44—6.03, 49.0—85.8} [3,000]	←
Oil pump	Type	Trochoid gear type	←
	Relief valve opening pressure (reference value) (kPa {kgf/cm ² , psi})	420—520 {4.28—5.30, 60.9—75.4}	←
Oil filter	Type	Full-flow, paper element	←
	Bypass pressure (kPa {kgf/cm ² , psi})	80—120 {0.82—1.22, 11.6—17.4}	←
Engine oil capacity (approx. quantity) (AT, 5MT)	Total (dry engine) (L {US qt, Imp qt})	4.75 {5.02, 4.18}	4.6 {4.9, 4.0} ^{*1} 4.75 {5.02, 4.18} ^{*2}
	Oil replacement (L {US qt, Imp qt})	4.05 {4.28, 3.56}	3.9 {4.1, 3.4} ^{*1} 4.05 {4.28, 3.56} ^{*2}
	Oil and oil filter replacement (L {US qt, Imp qt})	4.45 {4.70, 3.92}	4.3 {4.5, 3.8} ^{*1} 4.45 {4.70, 3.92} ^{*2}
Engine oil capacity (approx. quantity) (6MT)	Total (dry engine) (L {US qt, Imp qt})	4.85 {5.12, 4.27}	←
	Oil replacement (L {US qt, Imp qt})	4.05 {4.28, 3.56}	←
	Oil and oil filter replacement (L {US qt, Imp qt})	4.55 {4.81, 4.00}	←
COOLING SYSTEM			
Type		Water-cooled, Electromotive	←
Coolant capacity (approx. quantity) (L {US qt, Imp qt})		7.5 {7.9, 6.6}	←
Water pump	Type	Centrifugal, V-ribbed belt-driven	←

OUTLINE [LF]

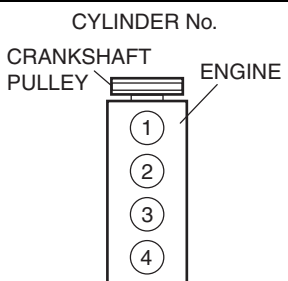
Item		Specification	
		2008MY	2007MY
		LF (2.0L)	LF (2.0L)
Thermostat	Type	Wax, bottom-bypass	←
	Opening temperature (°C {°F})	80—84 {176—183}	←
	Full-open temperature (°C {°F})	97 {207}	←
	Full-open lift (mm {in})	8.0 {0.31} or more	←
Radiator	Type	Corrugated fin	←
Cooling system cap	Cap valve opening pressure (kPa {kgf/cm ² , psi})	93.2—122.6 {0.95—1.25, 13.5—17.8}	←
Cooling fan	Type	Electric	←
	Number of blades	5	←
	Outer diameter (mm {in})	360 {14.2}	←
	Fan motor output (W)	120	←
FUEL SYSTEM			
Injector	Type	Hi-ohmic	←
	Type of fuel delivery	Top-feed	←
	Type of drive	Voltage	←
Pressure regulator control pressure (kPa {kgf/cm ² , psi})		Approx. 390 {3.98, 56.6}	←
Fuel pump type		Electric	←
Fuel tank capacity (L {US gal, Imp gal})		48 {12, 10}	←
Fuel type (Anti-knock index)		Premium unleaded fuel 91 [(R+M)/2 method] or above (96 RON or more)	←
EMISSION SYSTEM			
EGR type		Stepping motor	←
Catalyst form		WU-TWC (monolith), TWC (monolith)	←
Evaporative emission (EVAP) control system		Charcoal canister type	←
Positive crankcase ventilation (PCV) system		Closed type	←
CHARGING SYSTEM			
Battery	Voltage (V)	12	←
	Type and capacity (5-hour rate) (A·h)	46B24L (36)	←
Generator	Output (V·A)	12-100	←
	Regulated voltage	Controlled by PCM	←
	Self diagnosis function		←
IGNITION SYSTEM			
Ignition system	Type	SEI (Single Electronic Ignition)	←
	Spark advance	Electronic	←
	Firing order	1—3—4—2 (all cylinders independent firing)	←
		<div style="text-align: center;"> CYLINDER No.  </div>	←
Spark plug	Type	L3G2 18 110, L3Y1 18 110	←
STARTING SYSTEM			

OUTLINE [LF]

Item		Specification	
		2008MY	2007MY
		LF (2.0L)	LF (2.0L)
Starter	Type	Coaxial reduction	←
	Output (kW)	1.4	←

*1 : Applied VIN (Assumed)

JM1 NC15F*7# 100001—130613

JM1 NC16F*7# 100001—130613

JM1 NC25F*7# 100001—130613

JM1 NC26F*7# 100001—130613

*2 : Applied VIN (Assumed)



JM1 NC15F*7# 130614—

JM1 NC16F*7# 130614—

JM1 NC25F*7# 130614—

JM1 NC26F*7# 130614—

Engine oil specification

Item	U.S.A. and CANADA	Except U.S.A. and CANADA
Engine oil grade	 (ILSAC)	  (ILSAC) API SM or ILSAC
Engine oil viscosity	5W-20	5W-20 (If SAE 5W-20 engine oil is not available in your market, use SAE 5W-30 engine oil.)

ON-BOARD DIAGNOSTIC [LF]

01-02 ON-BOARD DIAGNOSTIC [LF]

ON-BOARD DIAGNOSTIC OUTLINE

[LF] 01-02-1
 Features 01-02-1

ON-BOARD DIAGNOSTIC SYSTEM

TEST MODE [LF] 01-02-1
 Sending Emission-related Malfunction
 Code 01-02-1
 Sending Intermittent Monitoring System
 Test Results 01-02-5

DTC DETECTION LOGIC AND

CONDITIONS [LF] 01-02-5
KOEO/KOER SELF-TEST [LF] 01-02-6
 KOEO (Key ON, Engine Off)
 Self-test 01-02-6
 KOER (Key ON, Engine Running)
 Self-test 01-02-6

PID/DATA MONITOR AND RECORD

[LF] 01-02-9
SIMULATION TEST [LF] 01-02-11

ON-BOARD DIAGNOSTIC OUTLINE [LF]

id010245100100

Features

To meet OBD-II regulations	<ul style="list-style-type: none"> Diagnostic monitoring system test results changed
Improved serviceability	<ul style="list-style-type: none"> DTC changed PID/DATA monitor function changed Simulation test function changed

ON-BOARD DIAGNOSTIC SYSTEM TEST MODE [LF]

id010245100200

Sending Emission-related Malfunction Code

- The DTCs are shown below.

×: Applicable
 N/A: Not applicable

DTC No.		Condition	MIL	DC	Monitor item	Self-test type*3	Memory function
2008MY	2007MY						
B1342	←	PCM malfunction	OFF	N/A	N/A	C, O	N/A
P0011	←	CMP timing over-advanced	ON	1	CCM	C, R	×
P0012	←	CMP timing over-retarded	ON	2	CCM	C, R	×
P0016	←	CKP-CMP correlation	ON	2	CCM	C	×
P0030	←	Front HO2S heater control circuit problem	ON	2	HO2S heater	C, O, R	×
P0031	←	Front HO2S heater circuit low input	ON	2	HO2S heater	C, O, R	×
P0032	←	Front HO2S heater circuit high input	ON	2	HO2S heater	C, O, R	×
P0037	←	Rear HO2S heater circuit low input	ON	2	HO2S heater	C, O, R	×
P0038	←	Rear HO2S heater circuit high input	ON	2	HO2S heater	C, O, R	×
P0069	←	Manifold absolute pressure/atmospheric pressure correlation	ON	2	CCM	C	×
P0101	←	MAF sensor circuit range/performance problem	ON	2	CCM	C	×
P0102	←	MAF sensor circuit low input	ON	1	CCM	C, O, R	×
P0103	←	MAF sensor circuit high input	ON	1	CCM	C, O, R	×
P0107	←	MAP sensor circuit low input	ON	1	CCM	C, O, R	×
P0108	←	MAP sensor circuit high input	ON	1	CCM	C, O, R	×
P0111	←	IAT sensor circuit range/performance problem	ON	2	CCM	C	×
P0112	←	IAT sensor circuit low input	ON	1	CCM	C, O, R	×
P0113	←	IAT sensor circuit high input	ON	1	CCM	C, O, R	×
P0116	←	Engine coolant temperature circuit range/performance	ON	1	Engine cooling system	C	×
P0117	←	ECT sensor circuit low input	ON	1	Engine cooling system	C, O, R	×
P0118	←	ECT sensor circuit high input	ON	1	Engine cooling system	C, O, R	×

ON-BOARD DIAGNOSTIC [LF]

DTC No.		Condition	MIL	DC	Monitor item	Self-test type ^{*3}	Memory function
2008MY	2007MY						
P0122	←	TP sensor No.1 circuit low input	ON	1	CCM	C, O, R	×
P0123	←	TP sensor No.1 circuit high input	ON	1	CCM	C, O, R	×
P0125	←	Excessive time to enter closed loop fuel control	ON	2	Engine cooling system	C	×
P0126	←	Coolant thermostat stuck open	ON	2	Engine cooling system	C	×
P0128	←		ON	2	Engine cooling system	C	×
P0130	←	Front HO2S circuit problem	ON	2	HO2S	C, O, R	×
P0131	←	Front HO2S circuit low input	ON	2	HO2S	C, O, R	×
P0132	←	Front HO2S circuit high input	ON	2	HO2S	C, O, R	×
P0133	←	Front HO2S circuit problem	ON	2	HO2S	C	×
P0134	←	Front HO2S no activity detected	ON	2	HO2S	C, R	×
P0137	←	Rear HO2S circuit low input	ON	2	HO2S	C, O, R	×
P0138	←	Rear HO2S circuit high input	ON	2	HO2S	C, O, R	×
P0139	←	Rear HO2S circuit problem	ON	2	HO2S	C	×
P0140	←	Rear HO2S no activity detected	ON	2	HO2S	C, R	×
P0222	←	TP sensor No.2 circuit low input	ON	1	CCM	C, O, R	×
P0223	←	TP sensor No.2 circuit high input	ON	1	CCM	C, O, R	×
P0300	←	Random misfire detected	Flash/ ON	1 or 2	Misfire	C, R	×
P0301	←	Cylinder No.1 misfire detected	Flash/ ON	1 or 2	Misfire	C, R	×
P0302	←	Cylinder No.2 misfire detected	Flash/ ON	1 or 2	Misfire	C, R	×
P0303	←	Cylinder No.3 misfire detected	Flash/ ON	1 or 2	Misfire	C, R	×
P0304	←	Cylinder No.4 misfire detected	Flash/ ON	1 or 2	Misfire	C, R	×
P0327	←	KS circuit low input	ON	1	CCM	C, O, R	×
P0328	←	KS circuit high input	ON	1	CCM	C, O, R	×
P0335	←	CKP sensor circuit problem	ON	1	CCM	C	×
P0340	←	CMP sensor circuit problem	ON	1	CCM	C	×
P0401	←	EGR flow insufficient detected	ON	2	EGR system	C, R	×
P0403	←	EGR valve (stepping motor) circuit problem	ON	2	CCM	C, O, R	×
P0421	←	Warm up catalyst system efficiency below threshold	ON	2	Catalyst	C	×
P0441	←	Evaporative emission control system incorrect purge flow	ON	2	Evaporative system	C, R	×
P0442	←	Evaporative emission control system leak detected (small leak)	ON	2	Evaporative system	C, R	×
P0443	←	Purge solenoid valve circuit problem	ON	2	CCM	C, O, R	×
P0446	←	Change over valve (COV) (EVAP system leak detection pump) stuck close	ON	2	CCM	C, R	×
P0455	←	Evaporative emission control system leak detected (gross leak)	ON	2	Evaporative system	C, R	×
P0456 ^{*1}	←	Evaporative emission control system leak detected (very small leak)	ON	2	Evaporative system	C, R	×
P0461	←	Fuel gauge sender unit range/performance problem	ON	2	CCM	C	×
P0462	←	Fuel gauge sender unit circuit low input	ON	2	CCM	C, O, R	×
P0463	←	Fuel gauge sender unit circuit high input	ON	2	CCM	C, O, R	×
P0480	←	Cooling fan relay No.1 control circuit malfunction	OFF	1	Other	C, O, R	×
P0481	←	Cooling fan relay No.2 control circuit malfunction	OFF	1	Other	C, O, R	×

ON-BOARD DIAGNOSTIC [LF]

DTC No.		Condition	MIL	DC	Monitor item	Self-test type*3	Memory function
2008MY	2007MY						
P0482	←	Cooling fan relay No.3 control circuit malfunction	OFF	1	Other	C, O, R	×
P0500*4	←	VSS circuit problem	ON	2	CCM	C	×
P0505	←	Idle speed control system problem	OFF	N/A	N/A	R	N/A
P0506	←	Idle speed control system RPM lower than expected	ON	2	CCM	C	×
P0507	←	Idle speed control system RPM higher than expected	ON	2	CCM	C	×
P050A	←	Cold start idle air control system performance	ON	2	Cold start emission reduction strategy monitoring	C, R	×
P050B	←	Cold start ignition timing performance	ON	2	Cold start emission reduction strategy monitoring	C, R	×
P0550	←	PSP switch circuit malfunction	ON	2	CCM	C	×
P0564	←	Cruise control switch circuit malfunction	OFF	1	Other	C	×
P0571	←	Brake switch circuit problem	OFF	1	Other	C	×
P0601	←	PCM memory check sum error	ON	1	CCM	C, O, R	×
P0602	←	PCM programming error	ON	1	CCM	C, O, R	×
P0604	←	PCM random access memory (RAM) error	ON	1	CCM	C, O, R	×
P0606	←	PCM processor	ON	1	CCM	C, O, R	×
P0610	←	PCM vehicle options error	ON	1	CCM	C, O, R	×
P0638	←	Throttle actuator control circuit range/performance problem	ON	1	CCM	C	×
P0661	←	Variable intake air solenoid valve circuit low input	OFF	1	Other	C, O, R	×
P0662	←	Variable intake air solenoid valve circuit high input	OFF	1	Other	C, O, R	×
P0703	←	Brake switch input circuit problem	ON	2	CCM	C	×
P0704*2	←	Clutch pedal position (CPP) switch input circuit problem	ON	2	CCM	C	×
P0850*2	←	Neutral switch input circuit problem	ON	2	CCM	C	×
P1260	←	Immobilizer system problem	OFF	1	Other	C, O	N/A
P2004*5	N/A	Variable tumble shutter valve stuck open	ON	2	CCM	C, R	×
P2006*5	N/A	Variable tumble shutter valve stuck closed	ON	2	CCM	C, R	×
P2009*5	N/A	Variable tumble solenoid valve circuit low input	ON	2	CCM	C, O, R	×
P2010*5	N/A	Variable tumble solenoid valve circuit high input	ON	2	CCM	C, O, R	×
P2088	←	Oil control valve (OCV) circuit low	ON	1	CCM	C, O, R	×
P2089	←	Oil control valve (OCV) circuit high	ON	1	CCM	C, O, R	×
P2096	←	Target A/F feedback system too lean	ON	2	Fuel system	C	×
P2097	←	Target A/F feedback system too rich	ON	2	Fuel system	C	×
P2101	←	Throttle actuator circuit range/performance	ON	1	CCM	C, R	×
P2107	←	Throttle actuator control module processor error	ON	1	CCM	C, R	×
P2108	←	Throttle actuator control module performance error	ON	1	CCM	C, R	×
P2109	←	TP sensor minimum stop range/performance problem	ON	1	CCM	C, R	×

ON-BOARD DIAGNOSTIC [LF]

DTC No.		Condition	MIL	DC	Monitor item	Self-test type*3	Memory function
2008MY	2007MY						
P2112	←	Throttle actuator control system range/performance problem	ON	1	CCM	C, R	×
P2119	←	Throttle actuator control throttle body range/performance problem	ON	2	CCM	C, R	×
P2122	←	APP sensor No.1 circuit low input	ON	1	CCM	C, O, R	×
P2123	←	APP sensor No.1 circuit high input	ON	1	CCM	C, O, R	×
P2127	←	APP sensor No.2 circuit low input	ON	1	CCM	C, O, R	×
P2128	←	APP sensor No.2 circuit high input	ON	1	CCM	C, O, R	×
P2135	←	TP sensor No.1/No.2 voltage correlation problem	ON	1	CCM	C, O, R	×
P2138	←	APP sensor No.1/No.2 voltage correlation problem	ON	1	CCM	C, O, R	×
P2177	←	Fuel system too lean at off idle	ON	2	Fuel system	C, R	×
P2178	←	Fuel system too rich at off idle	ON	2	Fuel system	C, R	×
P2187	←	Fuel system too lean at idle	ON	2	Fuel system	C, R	×
P2188	←	Fuel system too rich at idle	ON	2	Fuel system	C, R	×
P2195	←	Front HO2S signal stuck lean	ON	2	HO2S	C	×
P2196	←	Front HO2S signal stuck rich	ON	2	HO2S	C	×
P2228	←	BARO sensor circuit low input	ON	1	CCM	C, O, R	×
P2229	←	BARO sensor circuit high input	ON	1	CCM	C, O, R	×
P2401	←	EVAP system leak detection pump motor circuit low	ON	2	CCM	C, R	×
P2402	←	EVAP system leak detection pump motor circuit high	ON	2	CCM	C, R	×
P2404	←	EVAP system leak detection pump sense circuit problem	ON	2	CCM	C, R	×
P2405	←	EVAP system leak detection pump sense circuit low input	ON	2	CCM	C, R	×
P2407	←	EVAP system leak detection pump sense circuit intermittent	ON	2	CCM	C, R	×
P2502	←	Charging system voltage problem	OFF	1	Other	C, R	×
P2503	←	Charging system voltage low	OFF	1	Other	C, R	×
P2504	←	Charging system voltage high	OFF	1	Other	C, R	×
P2507	←	PCM B+ voltage low	ON	1	CCM	C, O, R	×
P2610	←	PCM internal engine off timer performance	ON	2	CCM	C	×

*1 : California emission regulation applicable model

*2 : MT

*3 : C: CMDTC self-test, O: KOEO self-test, R: KOER self-test

*4 : With ABS/DSC or MT without ABS/DSC

*5 : AT

ON-BOARD DIAGNOSTIC [LF]

Sending Intermittent Monitoring System Test Results

- The items supported by the sending intermittent monitoring system are shown below.

N/A: Not applicable

2008MY		2007MY		Description	Related system
OBD Monitor ID	Test ID	OBD Monitor ID	Test ID		
01	80	←		HO2S (Front) lean-to-rich response time (calculated)	HO2S
01	81	←		HO2S (Front) rich-to-lean response time (calculated)	
01	82	←		HO2S (Front) lean-to-rich response time (calculated)	
01	83	←		HO2S (Front) rich-to-lean response time (calculated)	
02	03	←		Low HO2S (Rear) voltage for switch time calculation (constant)	
02	04	←		High HO2S (Rear) voltage for switch time calculation (constant)	
02	05	←		HO2S (Rear) rich-to-lean response time (calculated)	
21	80	←		HO2S (Front) and HO2S (Rear) switching time ratio	
31	83	←		EGR pressure variation	EGR
3A	80	←		EVAP system leak detection pump large leak check	EVAP
3B	80	←		EVAP system leak detection pump small leak check	
3C	80 ^{*1}	←		EVAP system leak detection pump very small leak check	
3D	80	←		Purge flow monitor	
A2	0B	←		Cylinder No.1 average misfire counts for last 10 DC	Misfire
A2	0C	←		Cylinder No.1 misfire counts for last/current DC	
A3	0B	←		Cylinder No.2 average misfire counts for last 10 DC	
A3	0C	←		Cylinder No.2 misfire counts for last/current DC	
A4	0B	←		Cylinder No.3 average misfire counts for last 10 DC	
A4	0C	←		Cylinder No.3 misfire counts for last/current DC	
A5	0B	←		Cylinder No.4 average misfire counts for last 10 DC	
A5	0C	←		Cylinder No.4 misfire counts for last/current DC	
N/A		E1	80	Heat radiation ratio	Thermostat
N/A		E1	81	Engine coolant temperature	

*1 : California emission regulation applicable model

DTC DETECTION LOGIC AND CONDITIONS [LF]

id010245100300

- The detection condition of the following DTC has been changed from 2007MY.

P2004 Variable tumble shutter valve stuck open

- PCM monitors variable tumble shutter valve position using variable tumble shutter valve switch. If PCM turns the variable tumble solenoid valve on but variable tumble shutter valve position still remain open (variable tumble shutter valve switch off), PCM determines that variable tumble shutter valve has been stuck open.

P2006 Variable tumble shutter valve stuck closed

- PCM monitors variable tumble shutter valve position using variable tumble shutter valve switch. If variable tumble turns variable tumble solenoid valve off but variable tumble shutter valve position still remain close (variable tumble shutter valve position sensor on), PCM determines that variable tumble shutter valve has been stuck closed.

P2009 Variable tumble solenoid valve circuit low input

- The PCM monitors variable tumble solenoid valve control signal. If the PCM turns variable tumble solenoid valve off but voltage still remains low, the PCM determines that variable tumble solenoid valve circuit has a malfunction.

P2010 Variable tumble solenoid valve circuit high input

- The PCM monitors the variable tumble solenoid valve control signal. If the PCM turns variable tumble solenoid valve on but the voltage still remains high, the PCM determines that the variable tumble solenoid valve circuit has a malfunction.

ON-BOARD DIAGNOSTIC [LF]

KOEO/KOER SELF-TEST [LF]

id010245100400

- The self-test function consists of the KOEO (Key On Engine Off) self-test, performed when the ignition switch is turned to the ON position and the engine is stopped; and the KOER (Key On Engine Running) self-test, performed when idling. If a malfunction is detected when either self-test is executed, a DTC is displayed on the Mazda Modular Diagnostic System (M-MDS). Using the self-test function, the present malfunction or a successful repair is readily confirmed. Refer to the self-test function table for the corresponding DTCs.

KOEO (Key ON, Engine Off) Self-test

- The KOEO self-test is a powertrain control system self-diagnosis, performed when the ignition switch is turned to the ON position and the engine is stopped. A KOEO self-test begins when the connected Mazda Modular Diagnostic System (M-MDS) sends an execute command to the PCM.
- As the KOEO self-test is performed, the PCM performs the inspection for set DTCs and if a malfunction is detected the DTC is displayed on the Mazda Modular Diagnostic System (M-MDS).

KOER (Key ON, Engine Running) Self-test

- The KOER self-test is a powertrain control system self-diagnosis, performed when the ignition switch is turned to the ON position and the engine is idling. A KOER self-test begins when the connected Mazda Modular Diagnostic System (M-MDS) sends an execute command to the PCM.
- As the KOER self-test is performed, the PCM performs the inspection for set DTCs and if a malfunction is detected the DTC is displayed on the Mazda Modular Diagnostic System (M-MDS).

KOEO/KOER self-test table

×: Applicable
N/A: Not applicable

DTC No.		Condition	Test condition	
2008MY	2007MY		KOEO	KOER
B1342	←	PCM malfunction	×	N/A
P0011	←	CMP timing over-advanced	N/A	×
P0012	←	CMP timing over-retarded	N/A	×
P0016	←	CKP-CMP correlation	N/A	N/A
P0030	←	Front HO2S heater control circuit problem	×	×
P0031	←	Front HO2S heater circuit low input	×	×
P0032	←	Front HO2S heater circuit high input	×	×
P0037	←	Rear HO2S heater circuit low input	×	×
P0038	←	Rear HO2S heater circuit high input	×	×
P0069	←	Manifold absolute pressure/atmospheric pressure correlation	N/A	N/A
P0101	←	MAF sensor circuit range/performance problem	N/A	N/A
P0102	←	MAF sensor circuit low input	×	×
P0103	←	MAF sensor circuit high input	×	×
P0107	←	MAP sensor circuit low input	×	×
P0108	←	MAP sensor circuit high input	×	×
P0111	←	IAT sensor circuit range/performance problem	N/A	N/A
P0112	←	IAT sensor circuit low input	×	×
P0113	←	IAT sensor circuit high input	×	×
P0116	←	Engine coolant temperature circuit range/performance	N/A	N/A
P0117	←	ECT sensor circuit low input	×	×
P0118	←	ECT sensor circuit high input	×	×
P0122	←	TP sensor No.1 circuit low input	×	×
P0123	←	TP sensor No.1 circuit high input	×	×
P0125	←	Excessive time to enter closed loop fuel control	N/A	N/A
P0126	←	Coolant thermostat stuck open	N/A	N/A
P0128	←		N/A	N/A
P0130	←	Front HO2S circuit problem	×	×
P0131	←	Front HO2S circuit low input	×	×
P0132	←	Front HO2S circuit high input	×	×
P0133	←	Front HO2S circuit problem	N/A	N/A
P0134	←	Front HO2S no activity detected	N/A	×
P0137	←	Rear HO2S circuit low input	×	×
P0138	←	Rear HO2S circuit high input	×	×

ON-BOARD DIAGNOSTIC [LF]

DTC No.		Condition	Test condition	
2008MY	2007MY		KOEO	KOER
P0139	←	Rear HO2S circuit problem	N/A	N/A
P0140	←	Rear HO2S no activity detected	N/A	×
P0222	←	TP sensor No.2 circuit low input	×	×
P0223	←	TP sensor No.2 circuit high input	×	×
P0300	←	Random misfire detected	N/A	×
P0301	←	Cylinder No.1 misfire detected	N/A	×
P0302	←	Cylinder No.2 misfire detected	N/A	×
P0303	←	Cylinder No.3 misfire detected	N/A	×
P0304	←	Cylinder No.4 misfire detected	N/A	×
P0327	←	KS circuit low input	×	×
P0328	←	KS circuit high input	×	×
P0335	←	CKP sensor circuit problem	N/A	N/A
P0340	←	CMP sensor circuit problem	N/A	N/A
P0401	←	EGR flow insufficient detected	N/A	×
P0403	←	EGR valve (stepping motor) circuit problem	×	×
P0421	←	Warm up catalyst system efficiency below threshold	N/A	N/A
P0441	←	Evaporative emission control system incorrect purge flow	N/A	×
P0442	←	Evaporative emission control system leak detected (small leak)	N/A	×
P0443	←	Purge solenoid valve circuit problem	×	×
P0446	←	Change over valve (COV) (EVAP system leak detection pump) stuck close	N/A	×
P0455	←	Evaporative emission control system leak detected (gross leak)	N/A	×
P0456 ^{*1}	←	Evaporative emission control system leak detected (very small leak)	N/A	×
P0461	←	Fuel gauge sender unit range/performance problem	N/A	N/A
P0462	←	Fuel gauge sender unit circuit low input	×	×
P0463	←	Fuel gauge sender unit circuit high input	×	×
P0480	←	Cooling fan relay No.1 control circuit malfunction	×	×
P0481	←	Cooling fan relay No.2 control circuit malfunction	×	×
P0482	←	Cooling fan relay No.3 control circuit malfunction	×	×
P0500 ^{*4}	←	VSS circuit problem	N/A	N/A
P0505	←	Idle speed control system problem	N/A	×
P0506	←	Idle speed control system RPM lower than expected	N/A	N/A
P0507	←	Idle speed control system RPM higher than expected	N/A	×
P050A	←	Cold start idle air control system performance	×	×
P050B	←	Cold start ignition timing performance	×	×
P0550	←	PSP switch circuit malfunction	N/A	N/A
P0564	←	Cruise control switch circuit malfunction	N/A	N/A
P0571	←	Brake switch circuit problem	N/A	N/A
P0601	←	PCM memory check sum error	×	×
P0602	←	PCM programming error	×	×
P0604	←	PCM random access memory (RAM) error	×	×
P0606	←	PCM processor	×	×
P0610	←	PCM vehicle options error	×	×
P0638	←	Throttle actuator control circuit range/performance problem	N/A	N/A
P0661	←	Variable intake air solenoid valve circuit low input	×	×
P0662	←	Variable intake air solenoid valve circuit high input	×	×
P0703	←	Brake switch input circuit problem	N/A	N/A
P0704 ^{*2}	←	Clutch pedal position (CPP) switch input circuit problem	N/A	N/A
P0850 ^{*2}	←	Neutral switch input circuit problem	N/A	N/A
P1260	←	Immobilizer system problem	×	N/A
P2004 ^{*5}	N/A	Variable tumble shutter valve stuck open	×	×
P2006 ^{*5}	N/A	Variable tumble shutter valve stuck closed	×	×
P2009 ^{*5}	N/A	Variable tumble solenoid valve circuit low input	×	×

ON-BOARD DIAGNOSTIC [LF]

DTC No.		Condition	Test condition	
2008MY	2007MY		KOEO	KOER
P2010 ^{*5}	N/A	Variable tumble solenoid valve circuit high input	×	×
P2088	←	Oil control valve (OCV) circuit low	×	×
P2089	←	Oil control valve (OCV) circuit high	×	×
P2096	←	Target A/F feedback system too lean	N/A	N/A
P2097	←	Target A/F feedback system too rich	N/A	N/A
P2101	←	Throttle actuator circuit range/performance	N/A	×
P2107	←	Throttle actuator control module processor error	N/A	×
P2108	←	Throttle actuator control module performance error	N/A	×
P2109	←	TP sensor minimum stop range/performance problem	N/A	×
P2112	←	Throttle actuator control system range/performance problem	N/A	×
P2119	←	Throttle actuator control throttle body range/performance problem	N/A	×
P2122	←	APP sensor No.1 circuit low input	×	×
P2123	←	APP sensor No.1 circuit high input	×	×
P2127	←	APP sensor No.2 circuit low input	×	×
P2128	←	APP sensor No.2 circuit high input	×	×
P2135	←	TP sensor No.1/No.2 voltage correlation problem	×	×
P2138	←	APP sensor No.1/No.2 voltage correlation problem	×	×
P2177	←	Fuel system too lean at off idle	N/A	×
P2178	←	Fuel system too rich at off idle	N/A	×
P2187	←	Fuel system too lean at idle	N/A	×
P2188	←	Fuel system too rich at idle	N/A	×
P2195	←	Front HO2S signal stuck lean	N/A	N/A
P2196	←	Front HO2S signal stuck rich	N/A	N/A
P2228	←	BARO sensor circuit low input	×	×
P2229	←	BARO sensor circuit high input	×	×
P2401	←	EVAP system leak detection pump motor circuit low	N/A	×
P2402	←	EVAP system leak detection pump motor circuit high	N/A	×
P2404	←	EVAP system leak detection pump sense circuit problem	N/A	×
P2405	←	EVAP system leak detection pump sense circuit low input	N/A	×
P2407	←	EVAP system leak detection pump sense circuit intermittent	N/A	×
P2502	←	Charging system voltage problem	N/A	×
P2503	←	Charging system voltage low	N/A	×
P2504	←	Charging system voltage high	N/A	×
P2507	←	PCM B+ voltage low	×	×
P2610	←	PCM internal engine off timer performance	N/A	N/A

*1 : California emission regulation applicable model

*2 : MT

*3 : C: CMDTC self-test, O: KOEO self-test, R: KOER self-test

*4 : With ABS/DSC or MT without ABS/DSC

*5 : AT

ON-BOARD DIAGNOSTIC [LF]

PID/DATA MONITOR AND RECORD [LF]

id010245100500

- The PID/DATA monitor items are shown below.

PID/DATA monitor table (reference)

Item		definition	Unit/Condition			PCM terminal
2008MY	2007MY		°C	°F		
AAT	←	Ambient air temperature	°C	°F	—	
AC_REQ	←	Refrigerant pressure switch (high, low)	On/Off			1AU
ACCS	←	A/C relay	On/Off			1I
AFR	←	Air/fuel ratio	—			2AD
AFR_ACT	←	Actual air/fuel ratio	—			—
ALTF	←	Generator field coil control duty value	%			2AI
ALTT V	←	Generator output voltage	V			2AJ
APP	←	Accelerator pedal position	%			1AO, 1AP
APP1	←	APP sensor No.1	%			1AO
	←		V			
APP2	←	APP sensor No.2	%			1AP
	←		V			
ARPMDES	←	Target engine speed	RPM			—
BARO	←	Barometric pressure	Pa	Bar	psi	—
	←		V			
BOO	←	Brake switch	On/Off			1AB, 1AF
BPA	←	Brake pressure applied switch	On/Off			—
CATT11_D SD	←	Catalyst temperature	°C	°F	—	
CHRGLP	←	Generator warning light	On/Off			—
COLP	←	Refrigerant pressure switch (middle)	ON/OFF			1J
CPP*1	←	Clutch pedal position	On/Off			1D
CPP/PNP*1	←	Shift lever position	Drive/Neutral			1X
DTCCNT	←	Number of DTC detected	—			—
ECT	←	Engine coolant temperature	°C	°F	—	
	←		V			
EQ_RAT11	←	Actual lambda signal	—			—
EQ_RAT11_DSD	←	Target lambda	—			—
ETC_ACT	←	Throttle control	°			—
ETC_DSD	←	Throttle control desired	%			—
	←		°			
EVAPCP	←	Purge solenoid valve duty value	%			2C
FAN1	←	Cooling fan relay No.1 control signal	On/Off			1M
FAN2	←	Cooling fan relay No.2 control signal	On/Off			1N
FAN3	←	Cooling fan relay No.3 control signal	On/Off			1R
FLI	←	Fuel level	%			—
FP	←	Fuel pump relay	On/Off			1H
FUELPW	←	Fuel injector duration	sec			2BB, 2BC, 2BD, 2AZ
FUELSYS	←	Fuel system status	OL/CL/ OL-Drive/ OL-Fault/ CL-Fault			—
GENVDSD	←	Target generator voltage	V			—
HTR11	←	Front HO2S heater control	On/Off			2BG
HTR12	←	Rear HO2S heater control	On/Off			2BE
IAT	←	Intake air temperature	°C	°F	—	
	←		V			
IMRC*6	N/A	Variable tumble solenoid valve	On/Off			2I
IMTV	←	Variable intake air control	On/Off			2J

ON-BOARD DIAGNOSTIC [LF]

Item		definition	Unit/Condition			PCM terminal
2008MY	2007MY					
INGEAR	←	Gears are engaged	On/Off			1D*1,1X*1 —*6
IVS	←	CTP condition	Idle/Off Idle			—
KNOCKR	←	Knocking retard	°			2U
LDP_EVAP CP	←	EVAP system leak detection pump detect incorrect purge flow	A			—
LDP_IDL	←	EVAP system leak detection pump idle current	A			—
LDP_MON	←	EVAP system leak detection pump monitoring current	A			—
LDP_REF	←	EVAP system leak detection pump reference current	A			—
LDP_SLDV	←	EVAP system small leak detection value	A			—
LDP_VSL_ FV*2	←	EVAP system very small leak detection fail value	mA/sec			—
LDP_VSL_ SV*2	←	EVAP system very small leak detection safe value	mA/sec			—
LDP_VSLD V*2	←	EVAP system very small leak detection value	mA/sec			—
LOAD	←	Engine load	%			—
LONGFT1	←	Long term fuel trim	%			—
MAF	←	Mass air flow	g/sec			1AK
	←		V			
MAP	←	Manifold absolute pressure	Pa	psi	Bar	2AG
	←		V			
MIL	←	Malfunction indicator lamp	On/Off			—
MIL_DIS	←	Travelled distance since MIL illuminated	km	mile		—
O2S11	←	Front HO2S	A			2AD
O2S12	←	Rear HO2S	V			2Q
PSP	←	PSP switch	Low/High			2T
RFCFLAG	←	PCM adaptive memory produce verification	Learnt/ Not Learnt			—
RO2FT1	←	Rear HO2S fuel trim	—			—
RPM	←	Engine speed	RPM			2W
SCCS	←	Cruise control switch	V			1AQ
SEGRP	←	EGR control	—			2K, 2G, 2L, 2H
SEGRP DSD	←	EGR valve position desired	%			—
SHRTFT1	←	Short term fuel trim (front)	%			—
SHRTFT12	←	Short term fuel trim (rear)	%			—
SPARKADV	←	Ignition timing	°			2S
test	←	Test mode	On/Off			—
TH_M	N/A	Heat radiation ratio (heat radiation when thermostat is malfunctioning/heat radiation when thermostat is normal) when thermostat monitoring is finished	—			—
	N/A	Engine coolant temperature when thermostat monitoring is finished	°C	°F		
TH_M_MA X	N/A	Upper limit of heat radiation ratio (heat radiation when thermostat is malfunctioning/heat radiation when thermostat is normal) for thermostat monitoring execution	—			—
	N/A	Upper limit of engine coolant temperature for thermostat monitoring execution	°C	°F		

ON-BOARD DIAGNOSTIC [LF]

Item		definition	Unit/Condition		PCM terminal
2008MY	2007MY				
TH_M_MIN	N/A	Lower limit of heat radiation ratio (heat radiation when thermostat is malfunctioning/heat radiation when thermostat is normal) for thermostat monitoring execution	—		—
	N/A	Lower limit of engine coolant temperature for thermostat monitoring execution	°C	°F	
TIRESIZE	←	Tire revolution per mile	rev/mile		—
TP_REL	←	Throttle position signal (relative value)	%		—
TP1	←	TP sensor No.1	%		2AK
	←		V		
TP2	←	TP sensor No.2	%		2AL
	←		V		
TPCT	←	TP sensor voltage at CTP	V		—
VPWR	←	Battery positive voltage	V		1BA
VSS	←	Vehicle speed	KPH	mph	2O ^{*4}
					1AM ^{*3, 5} , 1AI ^{*3, 5}
VT_ACT1	←	Actual valve timing	°		2E
VT_DIFF1	←	Difference between target valve timing and actual valve timing	°		—
VT_DUTY1	←	OCV control)	%		2E
VTC ^{*6}	N/A	Variable tumble shutter valve control	On/Off		2AE

- *1 : MT
- *2 : California emission regulation applicable model
- *3 : With ABS, DSC HU/CM
- *4 : MT without ABS/DSC
- *5 : AT without ABS/DSC
- *6 : AT

SIMULATION TEST [LF]

id010245100600

- The simulation items are shown below.

Simulation item table

×: Applicable
N/A: Not applicable

Item		Applicable component	Unit/condition	Test condition		PCM terminal
2008 MY	2007 MY			KOEO	KOER	
ACCS	←	A/C relay	Off/On	×	×	1I
ALTF	←	Generator (field coil)	%	N/A	×	2AI
ARPMDES	←	Target engine speed	RPM	×	×	—
EVAPCP	←	Purge solenoid valve	%	×	×	2C
FAN1	←	Cooling fan relay No.1	Off/On	×	×	1M
FAN2	←	Cooling fan relay No.2	Off/On	×	×	1N
FAN3	←	Cooling fan relay No.3	Off/On	×	×	1R
FP	←	Fuel pump relay	Off/On	×	×	1H
FUELPW1	←	Fuel injector	%	×	×	2BB, 2BC, 2BD, 2AZ
GENVDSD	←	Target generator voltage	V	N/A	×	—
HTR11	←	Front HO2S heater	Off/On	×	×	2BG
HTR12	←	Rear HO2S heater	Off/On	×	×	2BE
IMRC (AT)	N/A	Variable tumble solenoid valve	Off/On	×	×	2I
IMTV	←	Variable intake air solenoid valve	Off/On	×	×	2J
INJ_1	←	Fuel injector No.1	OFF	N/A	×	2BB
INJ_2	←	Fuel injector No.2	OFF	N/A	×	2BC
INJ_3	←	Fuel injector No.3	OFF	N/A	×	2BD

ON-BOARD DIAGNOSTIC [LF]

Item		Applicable component	Unit/condition	Test condition		PCM terminal
2008 MY	2007 MY			KOEO	KOER	
INJ_4	←	Fuel injector No.4	OFF	N/A	×	2AZ
SEGRP	←	EGR valve stepping motor position	—	×	×	2K, 2G, 2L, 2H
test	←	Test mode	Off/On	×	×	—
VT DUTY1 Wt	←	CMP sensor	%	×	×	2E

01-13 INTAKE-AIR SYSTEM [LF]

INTAKE-AIR SYSTEM OUTLINE

[LF]	01-13-1
Features	01-13-1
INTAKE-AIR SYSTEM	
STRUCTURAL VIEW [LF]	01-13-2
INTAKE-AIR SYSTEM DIAGRAM	
[LF]	01-13-3
INTAKE-AIR SYSTEM VACUUM HOSE	
ROUTING DIAGRAM [LF]	01-13-3
INTAKE MANIFOLD CONSTRUCTION	
[LF]	01-13-4
VARIABLE TUMBLE SYSTEM	
FUNCTION [LF]	01-13-4
AT	01-13-4
VARIABLE TUMBLE SYSTEM	
STRUCTURE [LF]	01-13-4
AT	01-13-4

VARIABLE TUMBLE SYSTEM

OPERATION [LF]	01-13-5
AT	01-13-5
VARIABLE TUMBLE SOLENOID VALVE	
FUNCTION [LF]	01-13-5
AT	01-13-5
VARIABLE TUMBLE SOLENOID VALVE CONSTRUCTION/OPERATION	
[LF]	01-13-5
AT	01-13-5
VARIABLE TUMBLE SHUTTER VALVE ACTUATOR	
FUNCTION [LF]	01-13-6
AT	01-13-6
VARIABLE TUMBLE SHUTTER VALVE ACTUATOR CONSTRUCTION/OPERATION [LF] ...	01-13-6
AT	01-13-6

INTAKE-AIR SYSTEM OUTLINE [LF]

id011345100100

Features

Improved engine torque	• Variable intake-air system adopted
Improved noise reduction	• Resonance chamber adopted
Improved emission gas purification	• Variable tumble system adopted (AT)

INTAKE-AIR SYSTEM [LF]

INTAKE-AIR SYSTEM STRUCTURAL VIEW [LF]

id011345100200

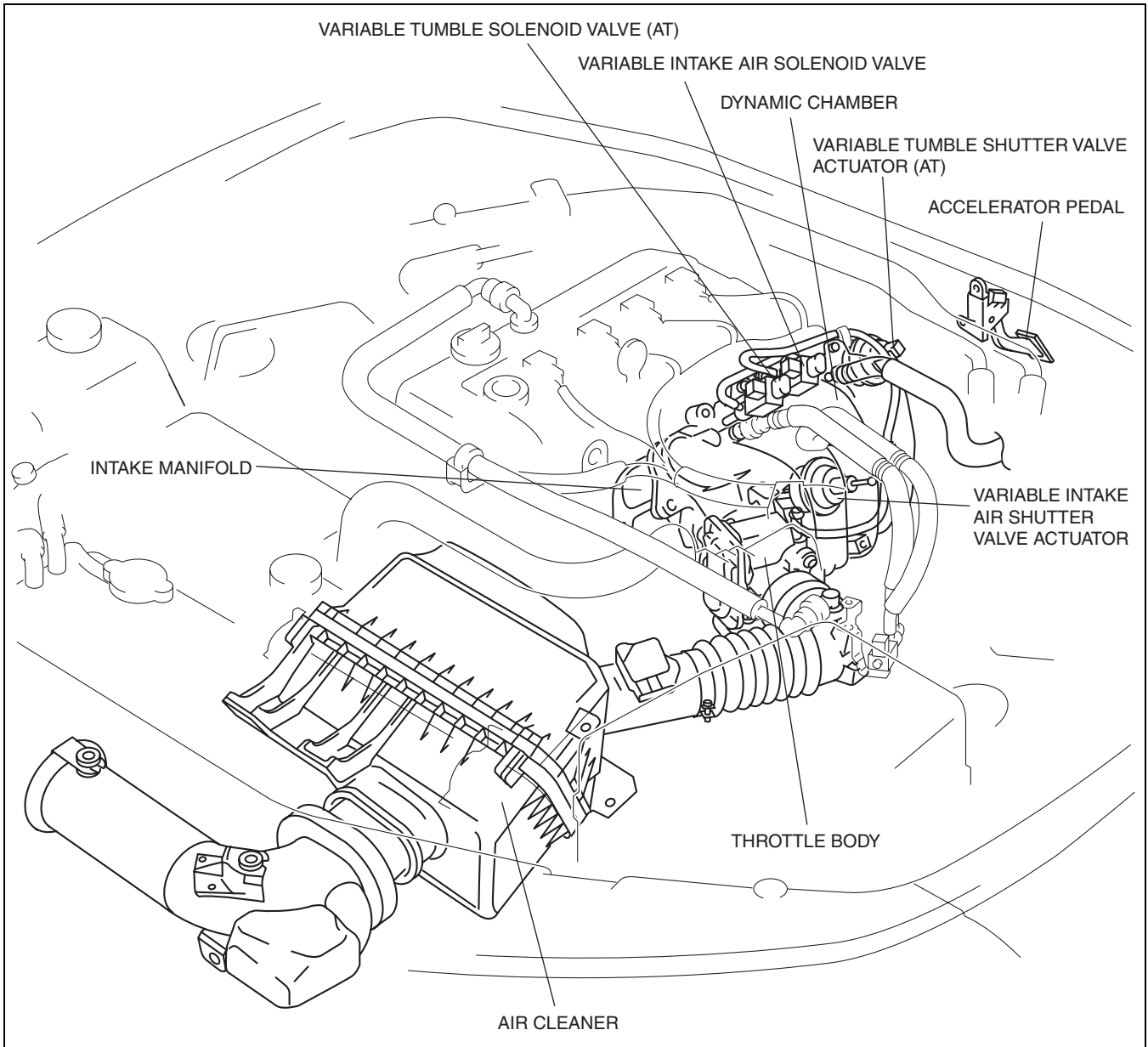

amxuun000006

INTAKE-AIR SYSTEM [LF]

INTAKE-AIR SYSTEM DIAGRAM [LF]

id011345102200

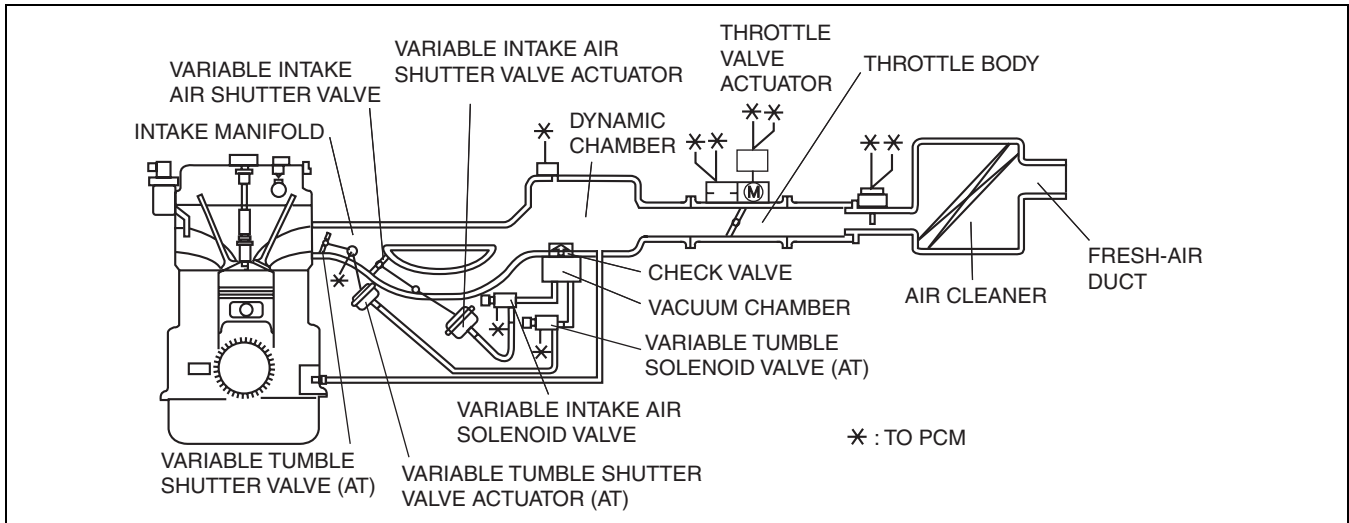

amxuun000006

INTAKE-AIR SYSTEM VACUUM HOSE ROUTING DIAGRAM [LF]

id011345100400

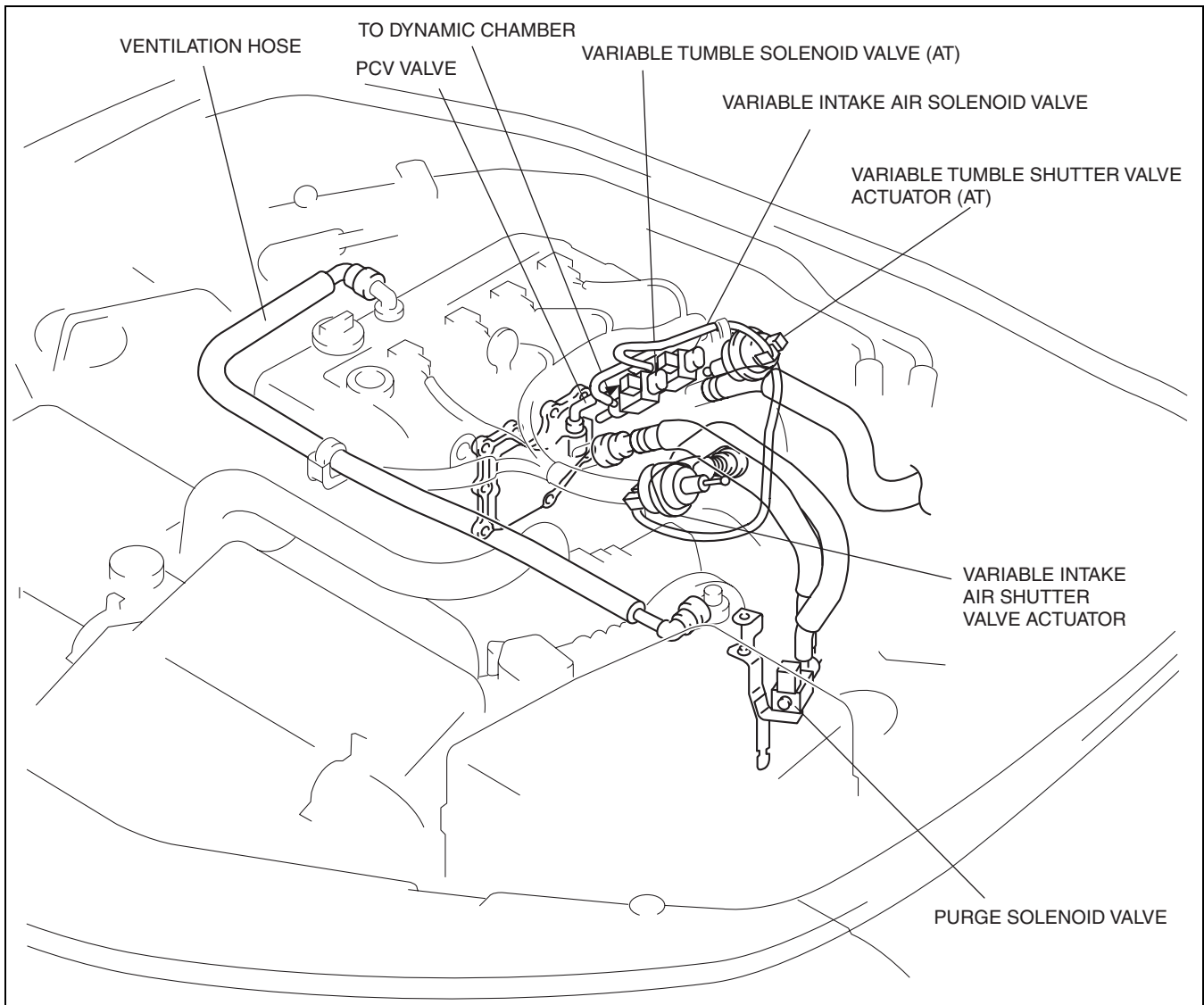

amxuuw0000076

Mazda MX-5

INTAKE-AIR SYSTEM [LF]

INTAKE MANIFOLD CONSTRUCTION [LF]

id011345100800

- The intake manifold mainly consists of the variable intake air shutter valve actuator and variable tumble shutter valve actuator (AT).
- Made of hard plastic for weight reduction.

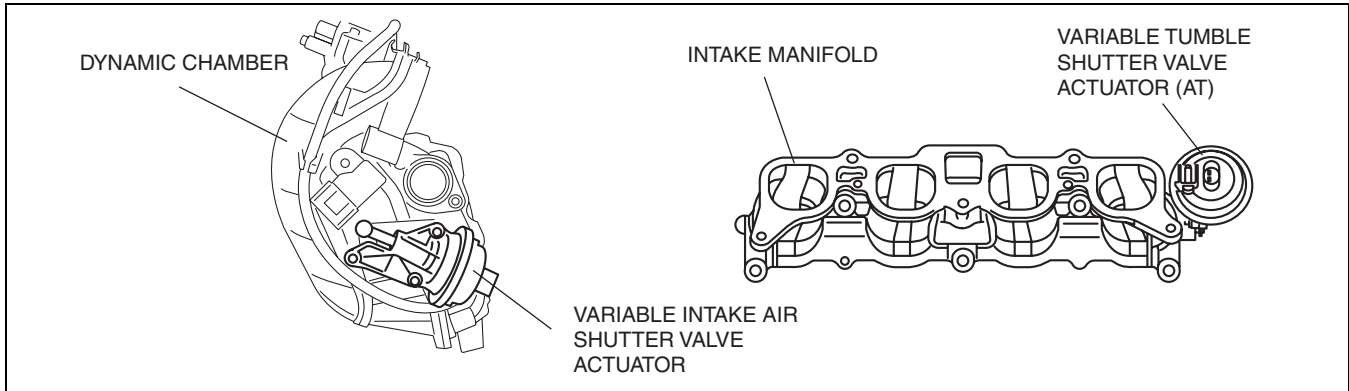

amxuun0000008

VARIABLE TUMBLE SYSTEM FUNCTION [LF]

id011345147300

AT

- The variable tumble system functions to lower emissions at cold-engine start.
- At cold-engine start, the variable tumble system increases intake airflow speed by closing the shutter valve and narrowing the intake passage. As a result, the air-fuel mixture quality from the injector is improved. Additionally, the creation of a powerful air tumble in the combustion chamber promotes the atomization of the air-fuel mixture. Due to this, exhaust emission efficiency is improved.
- For the variable tumble control, refer to CONTROL SYSTEM, Variable Tumble Control. (See 01-40-8 VARIABLE TUMBLE CONTROL OUTLINE [LF].) (See 01-40-8 VARIABLE TUMBLE CONTROL BLOCK DIAGRAM [LF].) (See 01-40-9 VARIABLE TUMBLE CONTROL OPERATION [LF].)

VARIABLE TUMBLE SYSTEM STRUCTURE [LF]

id011345147500

AT

- Mainly consists of the variable tumble solenoid valve, variable tumble shutter valve, variable tumble shutter valve actuator, and vacuum chamber.

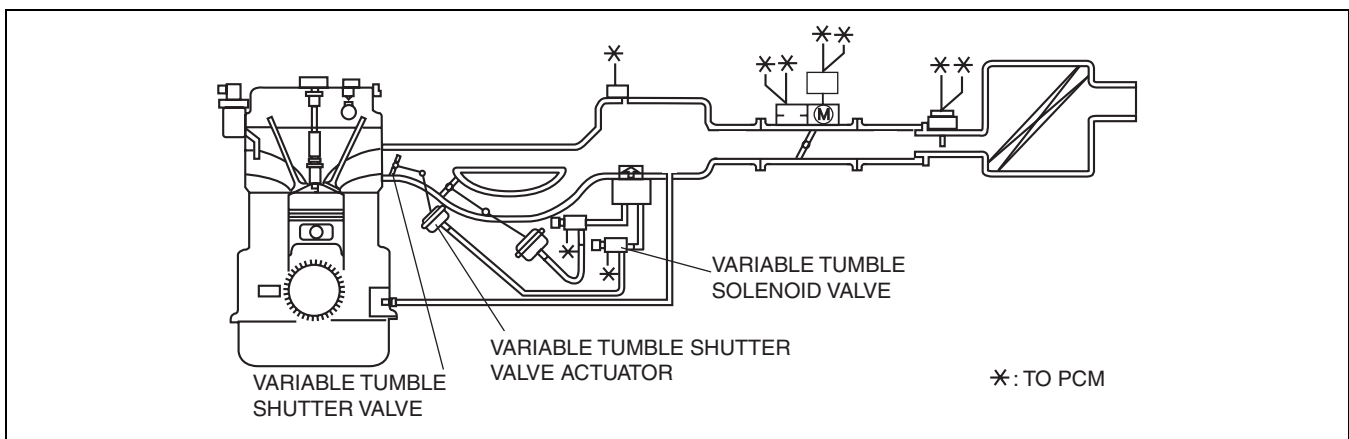

amxuun0000006

INTAKE-AIR SYSTEM [LF]

VARIABLE TUMBLE SYSTEM OPERATION [LF]

id011345147400

AT

Engine speed less than 3,750 rpm and engine coolant temperature less than 63 °C {145 °F} (variable tumble shutter valve is closed)

- Intake manifold vacuum is applied to the variable tumble shutter valve actuator by the operation of the variable tumble solenoid valve, closing the variable tumble shutter valve. At this time, the intake passage is narrower than normal, increasing intake airflow speed and also creating a powerful air tumble in the combustion chamber.

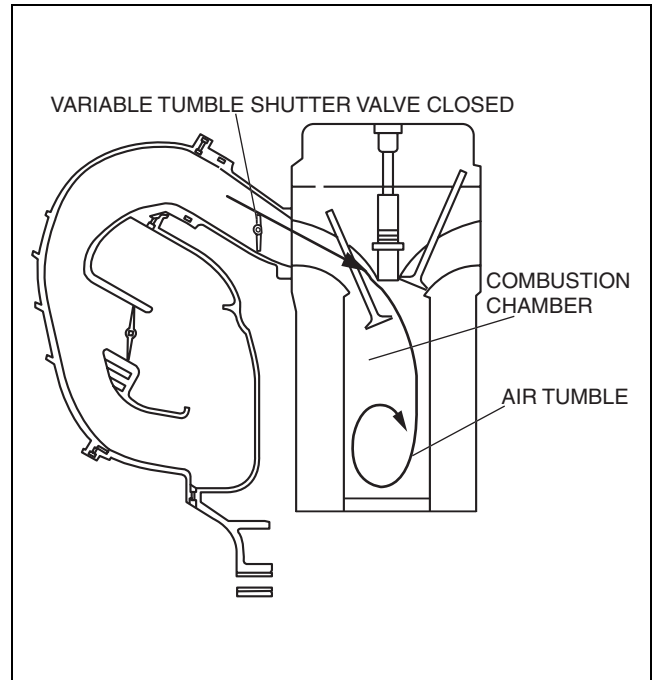

amxuun0000006

VARIABLE TUMBLE SOLENOID VALVE FUNCTION [LF]

id011345148200

AT

- Switches the intake manifold vacuum passage between the dynamic chamber and the variable tumble shutter actuator.

VARIABLE TUMBLE SOLENOID VALVE CONSTRUCTION/OPERATION [LF]

id011345148100

AT

Construction

- Mainly composed of the solenoid coil, spring, and plunger.

Operation

Energized

- The solenoid coil magnetizes, pulling the plunger. The passage between A and B ports opens due to the plunger being pulled, and intake manifold vacuum is applied to the actuator.

Not energized

- The intake manifold vacuum passage is blocked, and the passage between ports B and C opens, depressurizing the actuator.

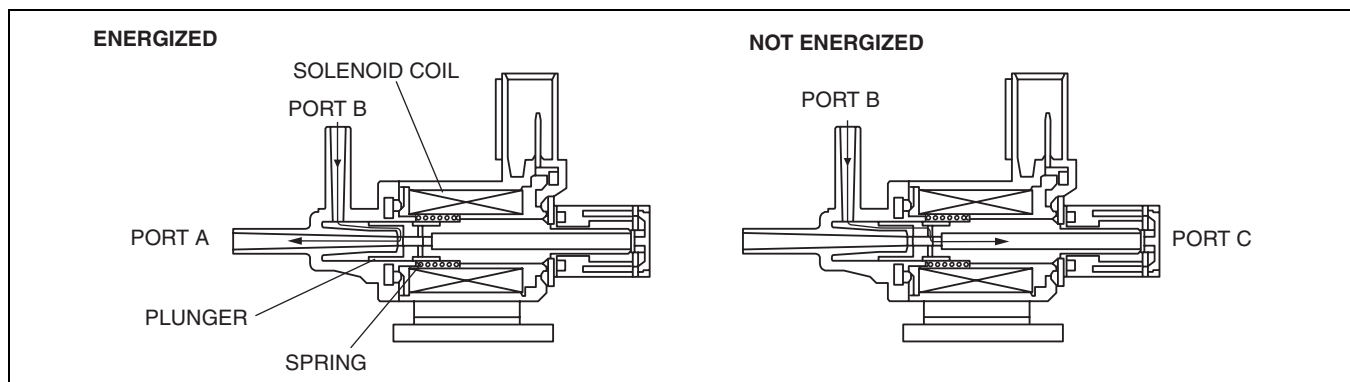

amxuun0000006

INTAKE-AIR SYSTEM [LF]

VARIABLE TUMBLE SHUTTER VALVE ACTUATOR FUNCTION [LF]

id011345148700

AT

- Opens and closes the variable tumble shutter valve.

VARIABLE TUMBLE SHUTTER VALVE ACTUATOR CONSTRUCTION/OPERATION [LF]

id011345151500

AT

Construction

- Mainly consists of the body, rod and diaphragm chamber spring.

Operation

- Normally, the spring force presses against the rod, keeping the variable tumble shutter valve open. When vacuum is applied to the diaphragm chamber from the dynamic chamber, the rod is pulled, closing the variable tumble shutter valve.

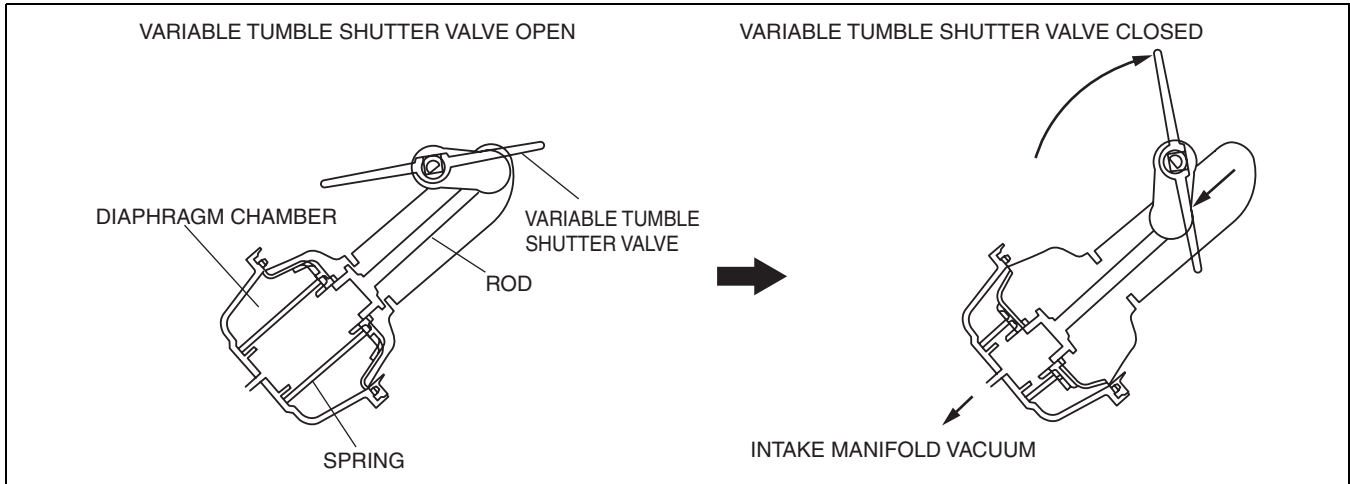

amxuun000007

01-40 CONTROL SYSTEM [LF]

<p>ENGINE CONTROL SYSTEM OUTLINE [LF] 01-40-1 Features 01-40-1 Specification 01-40-1</p> <p>ENGINE CONTROL SYSTEM STRUCTURAL VIEW [LF] 01-40-2</p> <p>ENGINE CONTROL SYSTEM DIAGRAM [LF] 01-40-3</p> <p>ENGINE CONTROL SYSTEM WIRING DIAGRAM [LF] 01-40-4</p> <p>ENGINE CONTROL SYSTEM BLOCK DIAGRAM [LF] 01-40-6</p> <p>ENGINE CONTROL SYSTEM RELATION CHART [LF] 01-40-7</p>	<p>VARIABLE TUMBLE CONTROL OUTLINE [LF] 01-40-8</p> <p>VARIABLE TUMBLE CONTROL BLOCK DIAGRAM [LF] 01-40-8</p> <p>VARIABLE TUMBLE CONTROL OPERATION [LF] 01-40-9 Operation conditions 01-40-9 Inhibition conditions 01-40-9</p> <p>PCM FUNCTION [LF] 01-40-9 Function List 01-40-9</p> <p>VARIABLE TUMBLE SHUTTER VALVE SWITCH FUNCTION [LF] 01-40-9</p> <p>VARIABLE TUMBLE SHUTTER VALVE SWITCH CONSTRUCTION/OPERATION [LF] 01-40-10</p>
--	---

ENGINE CONTROL SYSTEM OUTLINE [LF]

id014045100100

Features

Improved emission gas purification	• Variable tumble control adopted (AT)
------------------------------------	--

Specification

Item	Specification
Variable tumble shutter valve switch (AT)	ON/OFF

CONTROL SYSTEM [LF]

ENGINE CONTROL SYSTEM STRUCTURAL VIEW [LF]

id014045100200

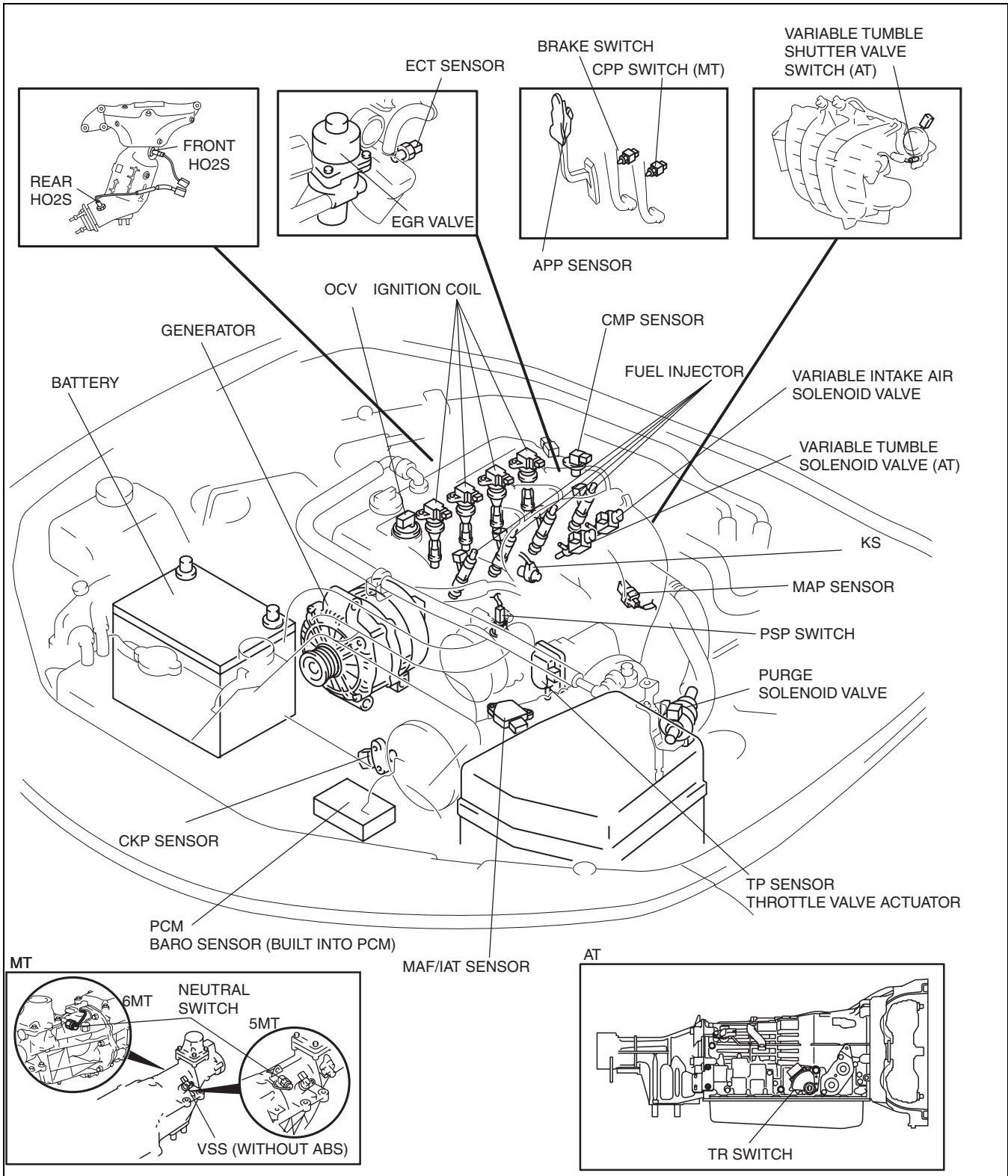

amxuun000007

CONTROL SYSTEM [LF]

ENGINE CONTROL SYSTEM DIAGRAM [LF]

id014045100300

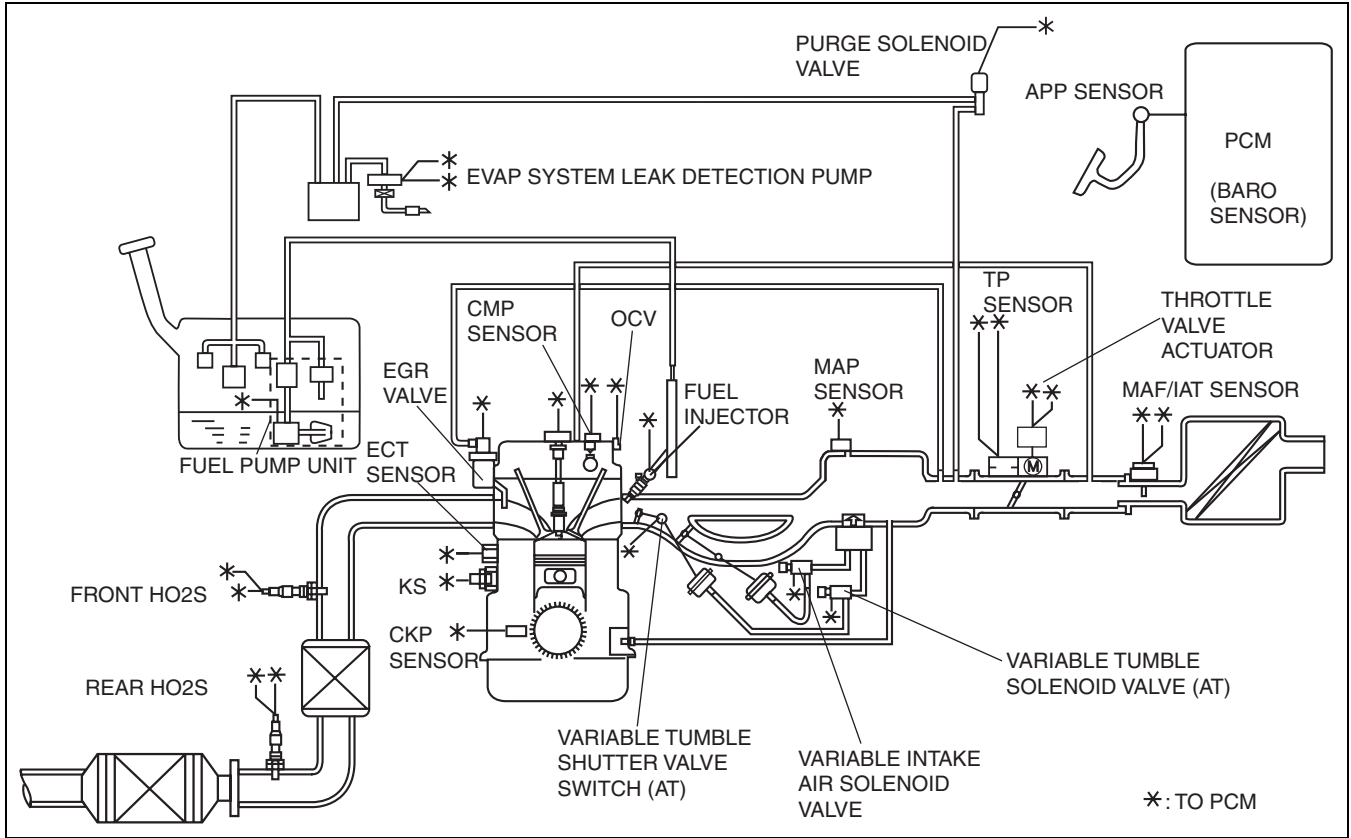

amxuun000017

Mazda MX-5

CONTROL SYSTEM [LF]

ENGINE CONTROL SYSTEM WIRING DIAGRAM [LF]

id014045100400

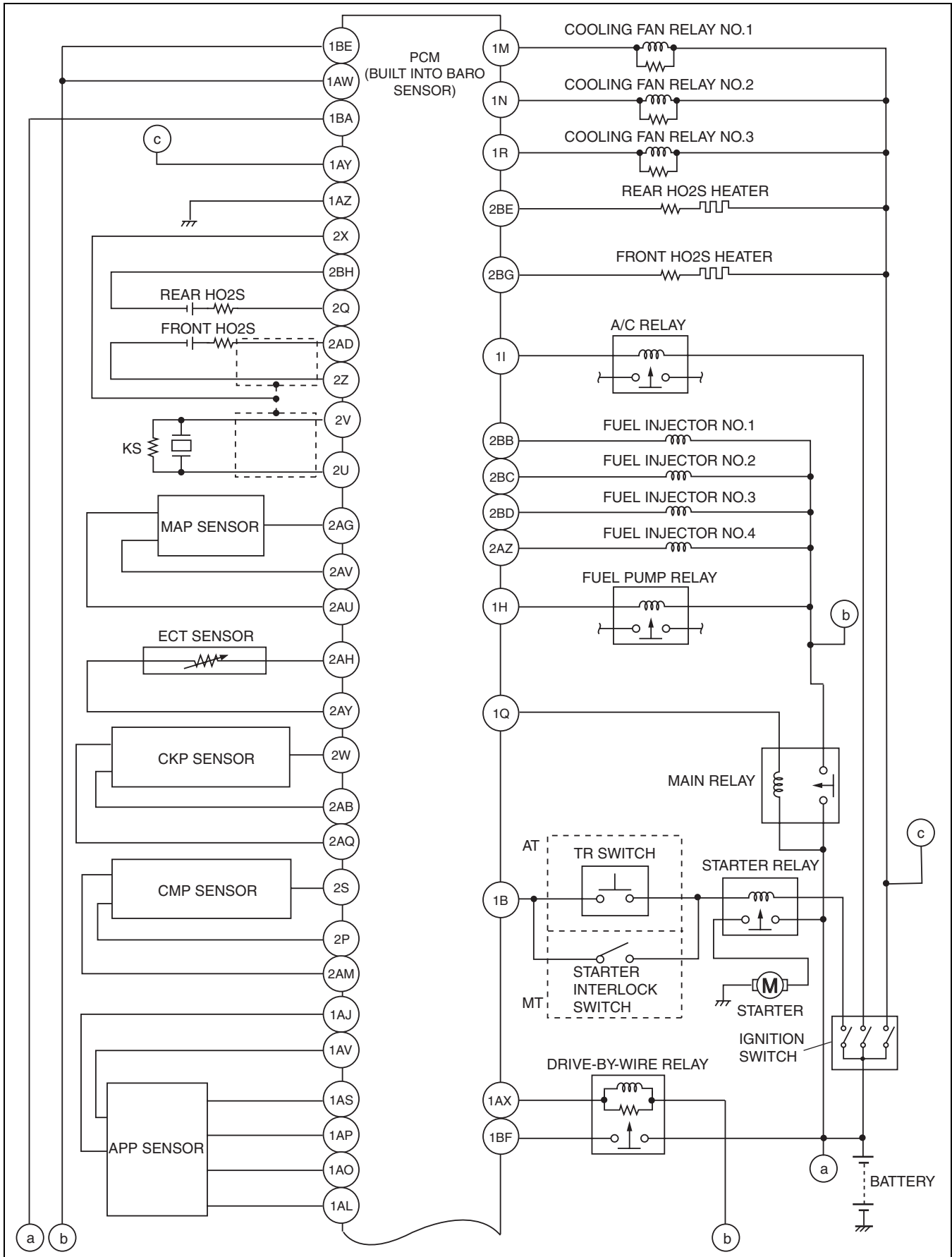

amxuun000007

CONTROL SYSTEM [LF]

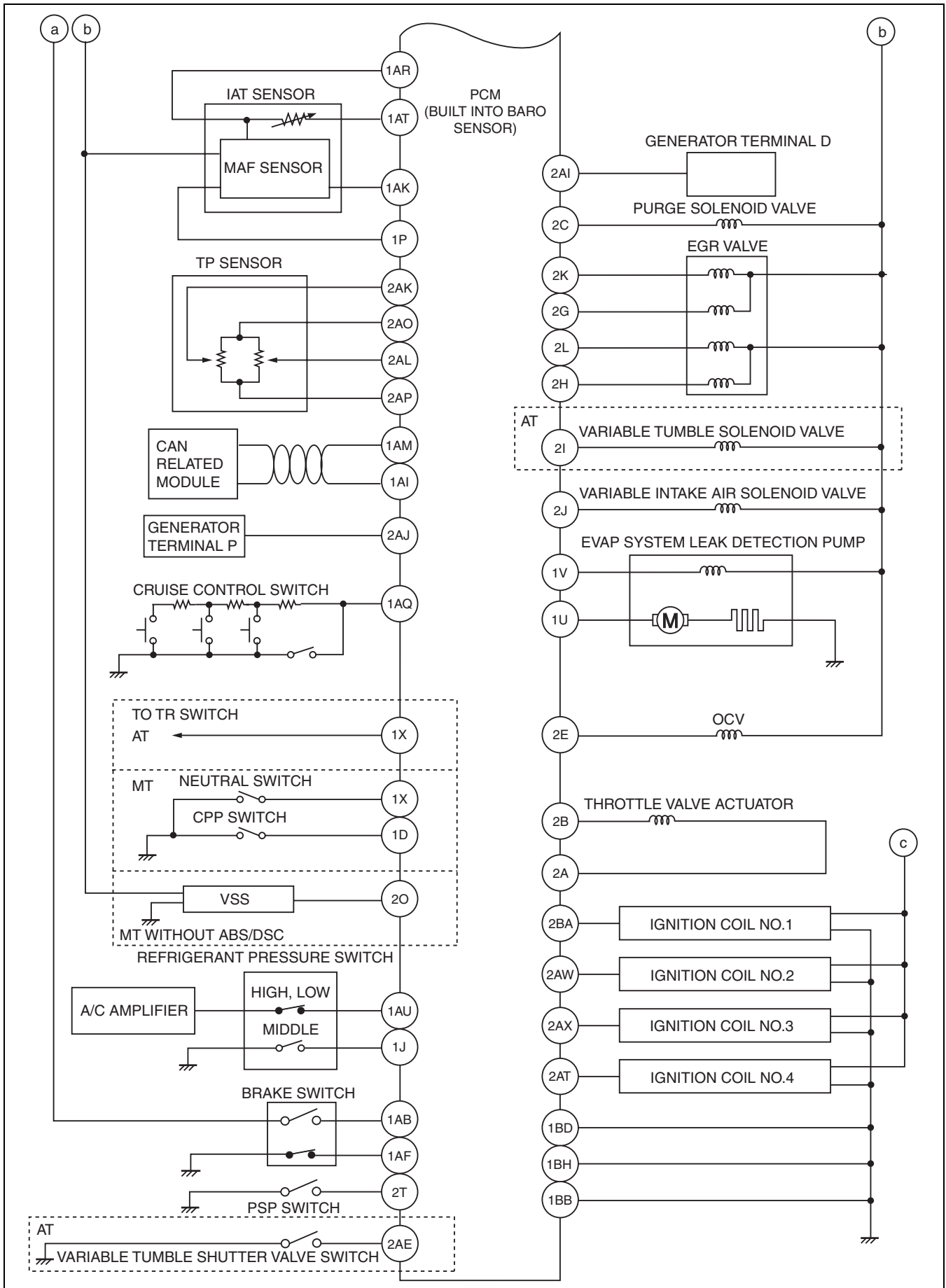

Mazda MX-5

amxuun000007

CONTROL SYSTEM [LF]

ENGINE CONTROL SYSTEM BLOCK DIAGRAM [LF]

id014045100500

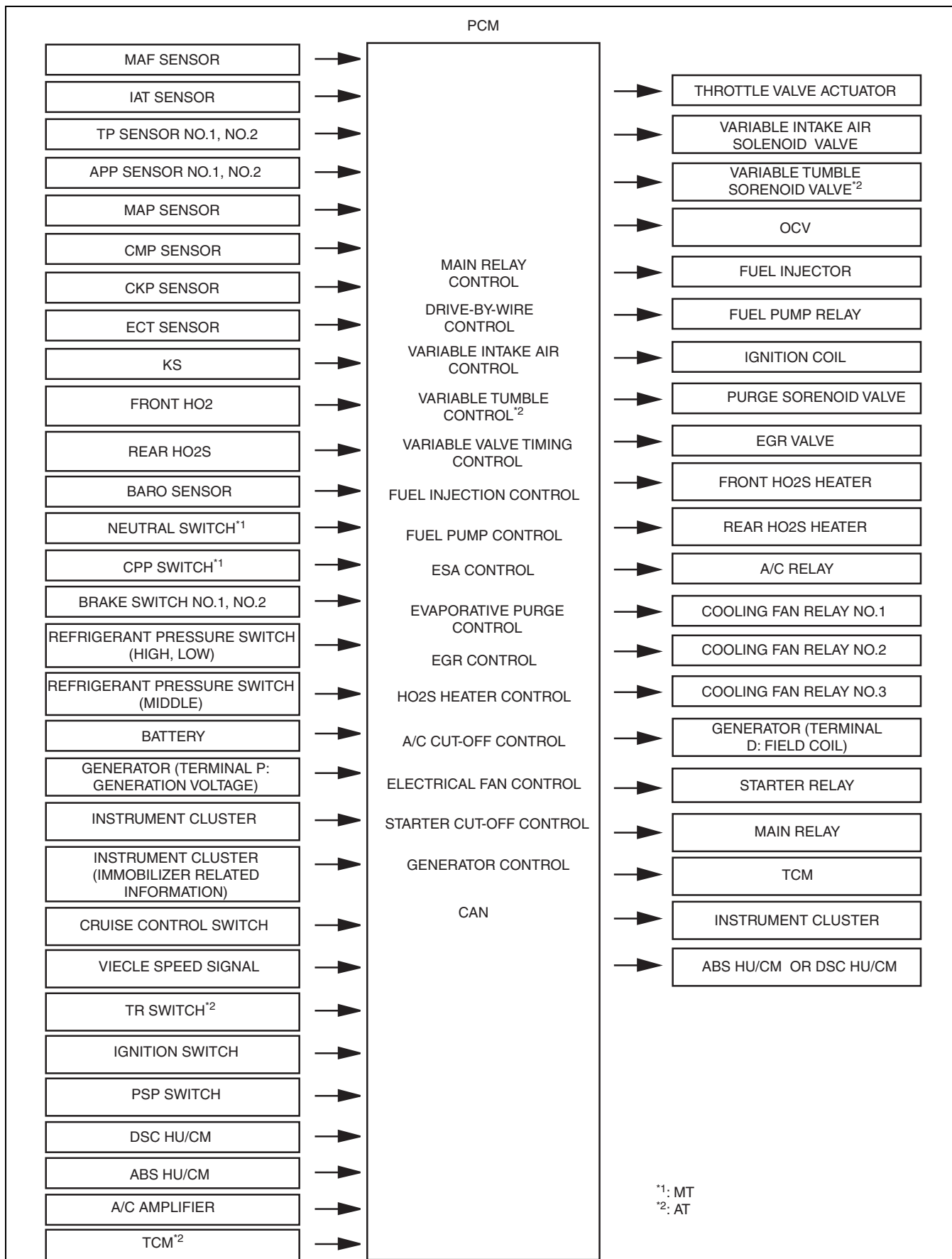

amxuun000009

CONTROL SYSTEM [LF]

ENGINE CONTROL SYSTEM RELATION CHART [LF]

id014045100600

X: Applied

Item	MAIN RELAY CONTROL	DRIVE-BY-WIRE CONTROL	VARIABLE INTAKE AIR CONTROL	VARIABLE TUMBLE CONTROL (AT)	VARIABLE VALVE TIMING CONTROL	FUEL INJECTION CONTROL	FUEL PUMP CONTROL	ESA CONTROL	EVAPORATIVE PURGE CONTROL	EGR CONTROL	HO2S HEATER CONTROL	A/C CUT-OFF CONTROL	ELECTRICAL FAN CONTROL	STARTER CUT-OFF CONTROL	GENERATOR CONTROL	CAN
Input device																
Neutral switch (MT)		X				X		X	X	X		X				
CPP switch (MT)		X				X		X		X		X				
ECT sensor		X		X	X	X		X	X	X	X	X	X		X	
IAT sensor		X				X		X	X	X	X		X		X	
CKP sensor		X	X	X	X	X	X	X	X	X	X	X			X	
CMP sensor					X	X		X								
TP sensor No.1, No.2		X	X	X	X	X		X	X	X	X	X	X			
APP sensor No.1, No.2		X				X		X				X				
MAF sensor		X			X	X		X	X	X	X					
Front HO2S						X			X							
Rear HO2S						X										
MAP sensor		X				X			X	X	X					
BARO sensor (Built into PCM)		X				X			X	X	X					
KS								X								
Ignition switch	X	X					X						X			
TR switch (AT)		X				X		X	X	X		X				
Brake switch No.1, No.2		X				X		X	X							
A/C amplifier		X				X		X				X	X			
Refrigerant pressure switch (high, low)		X				X		X				X	X			
Refrigerant pressure switch (middle)		X				X							X			
Cruise control switch		X														
PSP switch		X														
Vehicle speed signal		X				X		X		X			X		X	
Instrument cluster (Immobilizer related information)														X		
Instrument cluster																X
DSC HU/CM		X														
ABS HU/CM or DSC HU/CM																X
Generator (Terminal P: stator coil)		X						X							X	
Battery						X		X	X	X	X				X	
TCM (AT)		X						X								X
Output device																
Main relay	X															
Fuel pump relay							X									
A/C relay												X				
Cooling fan relay No.1													X			
Cooling fan relay No.2													X			
Cooling fan relay No.3													X			

CONTROL SYSTEM [LF]

Item	MAIN RELAY CONTROL	DRIVE-BY-WIRE CONTROL	VARIABLE INTAKE AIR CONTROL	VARIABLE TUMBLE CONTROL (AT)	VARIABLE VALVE TIMING CONTROL	FUEL INJECTION CONTROL	FUEL PUMP CONTROL	ESA CONTROL	EVAPORATIVE PURGE CONTROL	EGR CONTROL	HO2S HEATER CONTROL	A/C CUT-OFF CONTROL	ELECTRICAL FAN CONTROL	STARTER CUT-OFF CONTROL	GENERATOR CONTROL	CAN
Starter relay														X		
Purge solenoid valve									X							
EGR valve										X						
Variable intake air solenoid valve			X													
Variable tumble solenoid valve (AT)				X												
Throttle valve actuator		X														
Front HO2S heater											X					
Rear HO2S heater											X					
OCV					X											
TCM (AT)																X
Fuel injector						X										
Ignition coil								X								
Generator (Terminal D: field coil)															X	
Instrument cluster																X
ABS HU/CM or DSC HU/CM																X
Keyless control module																X

VARIABLE TUMBLE CONTROL OUTLINE [LF]

id014045176600

- At cold engine start, the following occur due to the closing of the variable tumble shutter valve for improved cold engine exhaust emission performance.
 - Improved intake airflow speed near injectors
 - Strong air tumble occurs in the combustion chamber, promoting vaporization mixture of intake air and fuel

VARIABLE TUMBLE CONTROL BLOCK DIAGRAM [LF]

id014045176400

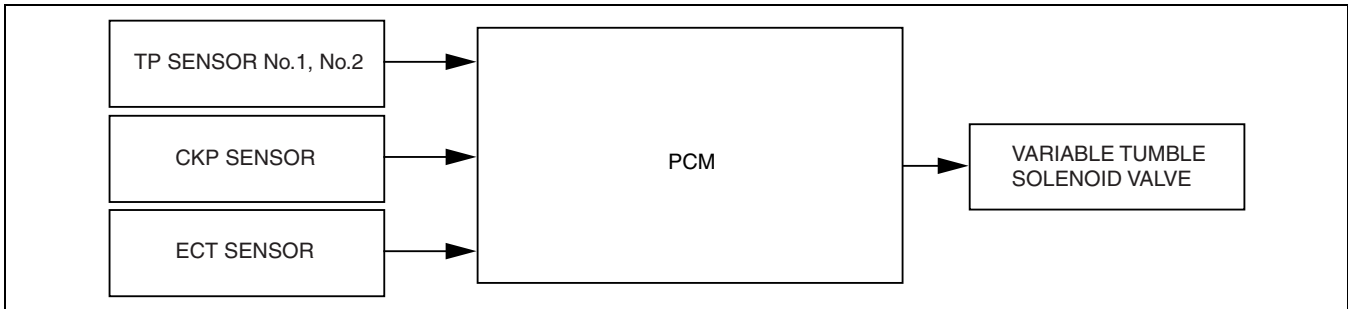

amxuun000007

CONTROL SYSTEM [LF]

VARIABLE TUMBLE CONTROL OPERATION [LF]

id014045176500

Operation conditions

- When all of the following conditions are met, the PCM energizes the coil of variable tumble solenoid valve. As a result, negative pressure is introduced to the diaphragm chamber of the variable tumble shutter valve actuator, pulling the actuator rod and closing the variable tumble shutter valve.
 - Engine speed **less than 3,750 rpm**
 - Engine coolant temperature **less than 63 °C {145 °F}**
 - Throttle valve opening angle is at the specified value or less (changes according to engine speed)

Inhibition conditions

- When a DTC for the ECT sensor or TP sensor has been stored, the variable tumble control is inhibited and the variable tumble shutter valve is constantly open.

PCM FUNCTION [LF]

id014045105300

Function List

- The control descriptions are as shown below.

Function	Description
Main relay control	When the ignition switch is turned to the ON position, the main relay turns on.
Drive-by-wire control	The drive-by-wire control calculates the optimum target throttle valve opening angle at all ranges of engine speeds and controls the throttle valve actuator.
Drive-by-wire relay control	Supplies power to the drive-by-wire control.
Variable intake air control	Switches energization of the variable shutter valve actuator according to engine speed to enhance the inertia charging effect.
Variable tumble control (AT)	At cold engine start, the following effects occur due to the closing of the variable tumble control for improved cold engine emission performance. <ul style="list-style-type: none"> • Improved intake airflow speed near injectors • Strong air tumble occurs in the combustion chamber, promoting vaporization mixture of intake air and fuel
Variable valve timing control	Changes the intake valve timing according to engine operation conditions to improve engine output, fuel economy and exhaust emission performance.
Fuel injection control	Performs optimum fuel injection according to engine operation conditions.
Fuel pump control	Performs energization of the fuel pump relay only when the engine is running (operates fuel pump) to improve stability and durability.
ESA control	Controls ignition to optimum timing according to engine operation conditions.
Evaporative purge control	An appropriate amount of evaporative gas is fed into the dynamic chamber by the driving of the purge solenoid valve according to the engine operation conditions to ensure driveability and prevent release of fuel vapor gas into the atmosphere.
EGR control	Adjusts the EGR to the optimum opening angle according to engine operation conditions.
HO2S heater control	Based on the control of the front and rear HO2S heater, a stabilized oxygen concentration is detected even at low exhaust gas temperature and feedback control of fuel injection even during cold engine start is made possible for improved cold temperature emission performance.
A/C cut-off control	The current application (energize/non-energize) to the A/C relay (magnetic clutch) is controlled according to the engine operation conditions to prevent deterioration of engine performance, damage to the engine, and deterioration of the A/C function.
Electrical fan control	Through cooling of the radiator and condenser by operation of the cooling fan according to vehicle conditions, engine reliability and cooling performance have been improved.
Starter cut-off control	Theft deterrence has been improved by controlling energization to the starter relay according to an engine stop request signal from the immobilizer system.
Generator control	Generator output is optimized according to the engine operation and electrical load conditions, ensuring idling stability and anti-load performance.
CAN	Used for communication with the EHPAS control module, ABS HU/CM, instrument cluster and DLC-2.

Mazda MX-5

VARIABLE TUMBLE SHUTTER VALVE SWITCH FUNCTION [LF]

id014045185700

- The variable tumble shutter valve switch detects whether the variable tumble shutter valve is open or closed.

CONTROL SYSTEM [LF]

VARIABLE TUMBLE SHUTTER VALVE SWITCH CONSTRUCTION/OPERATION [LF]

id014045990500

- The variable tumble shutter valve switch is installed in intake manifold.
- The characteristics of the variable tumble shutter valve switch are adjusted before shipment. Therefore, do not remove it from the intake manifold.

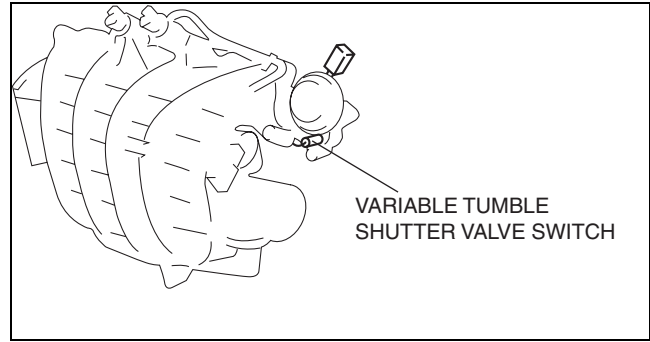

amxuun000007

- The output voltage characteristic of the variable tumble shutter valve switch is as shown in the figure.

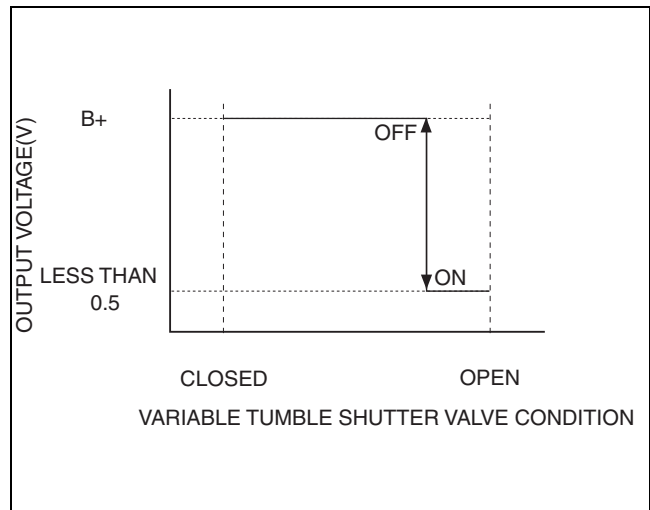

amxuun0000017