

**2007  
Mazda3  
MAZDASPEED3  
Mazda5  
Mazda6  
MAZDASPEED6  
Mazda MX-5  
Mazda RX-8**

## **Service Highlights**

### **FOREWORD**

This manual explains components, system operations and functions for the Mazda3, MAZDASPEED3, Mazda5, Mazda6, MAZDASPEED6, Mazda MX-5, Mazda RX-8.

For proper repair and maintenance, a thorough familiarization with this manual is important, and it should always be kept in a handy place for quick and easy reference.

All the contents of this manual, including drawings and specifications, are the latest available at the time of printing. As modifications affecting repair or maintenance occur, relevant information supplementary to this volume will be made available at Mazda dealers. This manual should be kept up-to-date.

Mazda Motor Corporation reserves the right to alter the specifications and contents of this manual without obligation or advance notice.

All rights reserved. No part of this book may be reproduced or used in any form or by any means, electronic or mechanical—including photocopying and recording and the use of any kind of information storage and retrieval system—without permission in writing.

**Mazda Motor Corporation  
HIROSHIMA, JAPAN**

#### **APPLICATION:**

This manual is applicable to vehicles beginning with the Vehicle Identification Numbers (VIN), and related materials shown on the following page.

**Mazda3  
MAZDASPEED3**

**Mazda5**

**Mazda6  
MAZDASPEED6**

**Mazda MX-5**

**Mazda RX-8**

**© 2006 Mazda Motor Corporation  
PRINTED IN U.S.A., JULY 2006  
Form No. 3422-1U-06G  
Part No. 9999-95-MODL-07**

# Mazda MX-5

## CONTENTS

TITLE	SECTION
ENGINE	01
BODY & ACCESSORIES	09



# ENGINE

**01**  
SECTION

<b>OUTLINE[LF]</b> . . . . .	<b>01-00</b>	<b>ON-BOARD DIAGNOSTIC</b>	
		<b>[LF].</b> . . . . .	<b>01-02</b>
		<b>CONTROL SYSTEM[LF]</b> . . . . .	<b>01-40</b>

## 01-00 OUTLINE [LF]

<b>ENGINE ABBREVIATIONS[LF]</b> . . . . .	<b>01-00-1</b>	<b>ENGINE SPECIFICATION[LF]</b> . . . . .	<b>01-00-2</b>
<b>ENGINE FEATURES[LF]</b> . . . . .	<b>01-00-1</b>	Specification . . . . .	<b>01-00-2</b>
On-board Diagnostic . . . . .	<b>01-00-1</b>		

### ENGINE ABBREVIATIONS[LF]

id0100e1100100

ABS	Antilock Brake System
AT	Automatic Transmission
ATDC	After Top Dead Center
BTDC	Before Top Dead Center
CAN	Controller Area Network
CCM	Comprehensive Component Monitor
CM	Control Module
DC	Drive Cycle
DSC	Dynamic Stability Control
EX	Exhaust
HU	Hydraulic Unit
IN	Intake
KOEO	Key On Engine Off
KOER	Key On Engine Running
MT	Manual Transmission
OCV	Oil Control Valve
PCV	Positive Crankcase Ventilation
PID	Parameter Identification
RAM	Random Access Memory

Mazda MX-5

### ENGINE FEATURES[LF]

id0100e1100200

#### On-board Diagnostic

To meet OBD-II regulations	<ul style="list-style-type: none"> <li>• Mode 03 of diagnostic test modes changed</li> </ul>
Improved serviceability	<ul style="list-style-type: none"> <li>• Mode 01, 06, and 08 of diagnostic test modes changed</li> </ul>

## OUTLINE [LF]

### ENGINE SPECIFICATION[LF]

id0100e1100300

#### Specification

Item			Specification		
			2007MY MX-5	2006MY MX-5	
			LF (2.0L)	LF (2.0L)	
<b>MECHANICAL</b>					
Type			DOHC-16 valves in-line, 4-cylinder	←	
Combustion chamber			Pentroof	←	
Displacement		(ml {cc, cu in})	1,999 {1,999, 122.0}	←	
Bore × stroke		(mm {in})	87.5 × 83.1 {3.44 × 3.27}	←	
Compression ratio			10:8	←	
Compression pressure		(kPa {kgf/cm <sup>2</sup> , psi} [rpm])	1,720 {17.54, 249.5} [300]	←	
Valve timing	IN	Open	BTDC (°)	0—30	←
		Close	ABDC (°)	32—62	←
	EX	Open	BBDC (°)	42	←
		Close	ATDC (°)	5	←
Valve clearance		(mm {in})	IN	0.22—0.28 {0.0087—0.011} [Engine cold]	←
			EX	0.27—0.33 {0.0107—0.0129} [Engine cold]	←
<b>LUBRICATION SYSTEM</b>					
Type			Force-fed type	←	
Oil pressure (reference value)		(kPa {kgf/cm <sup>2</sup> , psi} [rpm])	337—591 {3.44—6.03, 49.0— 85.8} [3,000]	←	
Oil pump	Type		Trochoid gear type	←	
	Relief valve opening pressure (reference value)	(kPa {kgf/cm <sup>2</sup> , psi})	420—520 {4.28—5.30, 60.9— 75.4}	←	
Oil filter	Type		Full-flow, paper element	←	
	Bypass pressure	(kPa {kgf/cm <sup>2</sup> , psi})	80—120 {0.82—1.22, 11.6— 17.4}	←	
Engine oil capacity (approx. quantity) (AT, 5MT)* <sup>1</sup>	Total (dry engine)		(L {US qt, Imp qt})	4.6 {4.9, 4.0}	←
	Oil replacement		(L {US qt, Imp qt})	3.9 {4.1, 3.4}	←
	Oil and oil filter replacement		(L {US qt, Imp qt})	4.3 {4.5, 3.8}	←
Engine oil capacity (approx. quantity) (AT, 5MT)* <sup>2</sup>	Total (dry engine)		(L {US qt, Imp qt})	4.75 {5.02, 4.18}	4.6 {4.9, 4.0}
	Oil replacement		(L {US qt, Imp qt})	4.05 {4.28, 3.56}	3.9 {4.1, 3.4}
	Oil and oil filter replacement		(L {US qt, Imp qt})	4.45 {4.70, 3.92}	4.3 {4.5, 3.8}
Engine oil capacity (approx. quantity) (6MT)	Total (dry engine)		(L {US qt, Imp qt})	4.85 {5.12, 4.27}	←
	Oil replacement		(L {US qt, Imp qt})	4.05 {4.28, 3.56}	←
	Oil and oil filter replacement		(L {US qt, Imp qt})	4.55 {4.81, 4.00}	←
<b>COOLING SYSTEM</b>					
Type			Water-cooled, Electromotive	←	
Coolant capacity (approx. quantity)		(L {US qt, Imp qt})	7.5 {7.9, 6.6}	←	
Water pump	Type		Centrifugal, V-ribbed belt-driven	←	

## OUTLINE [LF]

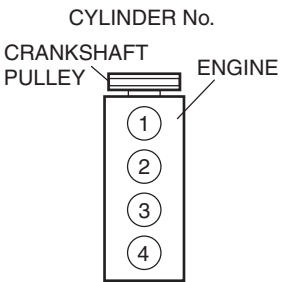

Item		Specification		
		2007MY MX-5	2006MY MX-5	
		LF (2.0L)	LF (2.0L)	
Thermostat	Type	Wax, bottom-bypass	←	
	Opening temperature (°C {°F})	80—84 {176—183}	←	
	Full-open temperature (°C {°F})	97 {207}	←	
	Full-open lift (mm {in})	8.0 {0.31} or more	←	
Radiator	Type	Corrugated fin	←	
Cooling system cap	Cap valve opening pressure (kPa {kgf/cm <sup>2</sup> , psi})	93.2—122.6 {0.95—1.25, 13.5—17.8}	←	
Cooling fan	Type	Electric	←	
	Number of blades	5	←	
	Outer diameter (mm {in})	360 {14.2}	←	
	Fan motor output (W)	120	←	
<b>FUEL SYSTEM</b>				
Injector	Type	Hi-ohmic	←	
	Type of fuel delivery	Top-feed	←	
	Type of drive	Voltage	←	
Pressure regulator control pressure (kPa {kgf/cm <sup>2</sup> , psi})		Approx. 390 {3.98, 56.6}	←	
Fuel pump type		Electric	←	
Fuel tank capacity (L {US gal, Imp gal})		48 {12, 10}	←	
Fuel type (Anti-knock index)		Premium unleaded fuel 91 [(R+M)/2 method] or adove (96 RON or more)	←	
<b>EMISSION SYSTEM</b>				
EGR type		Stepping motor	←	
Catalyst form		WU-TWC (monolith), TWC (monolith)	←	
Evaporative emission (EVAP) control system		Charcoal canister type	←	
Positive crankcase ventilation (PCV) system		Closed type	←	
<b>CHARGING SYSTEM</b>				
Battery	Voltage (V)	12	←	
	Type and capacity (5-hour rate) (A·h)	46B24L (36)	←	
Generator	Output (V·A)	12-100	←	
	Regulated voltage	Controlled by PCM	←	
	Self diagnosis function		←	
<b>IGNITION SYSTEM</b>				
Ignition system	Type	SEI (Single Electronic Ignition)	←	
	Spark advance	Electronic	←	
	Firing order		1—3—4—2 (all cylinders independent firing)	←
			<p>CYLINDER No.</p> 	←
Spark plug	Type	L3G2 18 110, L3Y1 18 110	←	

### OUTLINE [LF]

Item	Specification		
	2007MY MX-5		2006MY MX-5
	LF (2.0L)		LF (2.0L)
<b>STARTING SYSTEM</b>			
Starter	Type	Coaxial reduction	←
	Output (kW)	1.4	←

\*1 : Applied VIN (Assumed)  
 JM1 NC15F\*7# 100001—130613  
 JM1 NC16F\*7# 100001—130613  
 JM1 NC25F\*7# 100001—130613  
 JM1 NC26F\*7# 100001—130613  
 \*2 : Applied VIN (Assumed)  
 JM1 NC15F\*7# 130614—  
 JM1 NC16F\*7# 130614—  
 JM1 NC25F\*7# 130614—  
 JM1 NC26F\*7# 130614—

#### Engine oil specification

Item	U.S.A. and CANADA	Except U.S.A. and CANADA
Engine oil grade	 (ILSAC)	  (ILSAC)  API SM or ILSAC
Engine oil viscosity	5W-20	

## **01-02 ON-BOARD DIAGNOSTIC [LF]**

<b>DIAGNOSTIC TEST MODE[LF]</b> . . . . .	<b>01-02-1</b>	<b>DTC DETECTION LOGIC AND</b>	
Sending Diagnostic Data . . . . .	<b>01-02-2</b>	<b>CONDITIONS[LF]</b> . . . . .	<b>01-02-8</b>
Sending Freeze Frame Data . . . . .	<b>01-02-3</b>	<b>KOEO/KOER SELF-TEST[LF]</b> . . . . .	<b>01-02-17</b>
Sending Emission-related		KOEO (Key ON, Engine Off)	
Malfunction Code . . . . .	<b>01-02-4</b>	Self-test . . . . .	<b>01-02-17</b>
Sending Intermittent Monitoring		KOER (Key ON, Engine Running)	
System Test Results . . . . .	<b>01-02-7</b>	Self-test . . . . .	<b>01-02-17</b>
Sending Continuous Monitoring		<b>PID/DATA MONITOR AND</b>	
System Test Results . . . . .	<b>01-02-7</b>	<b>RECORD[LF]</b> . . . . .	<b>01-02-20</b>
DLC-2 Outline . . . . .	<b>01-02-8</b>	<b>SIMULATION TEST[LF]</b> . . . . .	<b>01-02-23</b>

### **DIAGNOSTIC TEST MODE[LF]**

id010245100200

- To meet OBD-II regulations, the following diagnostic test modes have been adopted.

<b>Diagnostic test mode</b>	<b>Item</b>
Mode 01	Sending diagnostic data (PID data monitor/On-board system readiness test)
Mode 02	Sending freeze frame data
Mode 03	Sending emission-related malfunction code (DTC)
Mode 04	Clearing/resetting emission-related malfunction information
Mode 06	Sending intermittent monitoring system test results (DMTR)
Mode 07	Sending continuous monitoring system test results (pending code)
Mode 08	On-board device control (simulation test, active command mode)
Mode 09	Request vehicle information

## ON-BOARD DIAGNOSTIC [LF]

### Sending Diagnostic Data

#### PID data monitor

- The PID data monitor items are shown below.

#### PID data monitor table

Full names	Unit	
Fuel system loop status	Refer to list below.	
LOAD	%	
ECT	°C	°F
Short term fuel trim	%	
Long term fuel trim	%	
MAP	kPa	
Engine speed	rpm	
Vehicle speed	km/h	mph
Spark advance	°	
IAT	°C	°F
MAF	g/s	
Absolute TP	%	
O2S location	No unit	
Input voltage from rear HO2S	V	
Short term fuel trim associated with rear HO2S	%	
OBD requirement according to vehicle design	No unit	
Time since engine start	s	
Distance travelled while MIL is activated	km	miles
EGR valve control signal	%	
Purge solenoid valve control signal	%	
Fuel level	%	
Number of warm-ups since DTCs cleared	No unit	
Distance travelled since DTCs cleared	km	miles
Barometric pressure	kPa	
Lambda	—	
Front HO2S output current	mA	
Estimated catalyst converter temperature	°C	°F
PCM voltage	V	
Absolute load value	%	
Theoretical air/fuel ratio coefficient to calculate target air/fuel ratio	No unit	
Relative TP	%	
Ambient air temperature	°C	°F
TP from TP sensor No.2	%	
APP from APP sensor No.1	%	
APP from APP sensor No.2	%	
Throttle actuator control signal	%	

#### Meaning of fuel system loop status

- The following information is displayed on the tester.
  - Feedback stops: ECT is lower than the determined feedback zone.
  - Feedback operating: HO2S being used for feedback is normal.
  - Feedback stops: Open loop due to driving condition
  - Feedback stops: Open loop due to detected system fault
  - Feedback operating: Malfunction occurred in HO2S (rear) system

## ON-BOARD DIAGNOSTIC [LF]

### On-board system readiness test

- The items supported by the on-board system readiness test are shown below.

#### Continuous monitoring system

- HO2S heater
- HO2S
- Fuel system
- Misfire
- CCM

#### Intermittent monitoring system

- HO2S heater
- HO2S
- Catalyst
- EGR system
- Evaporative system
- Engine cooling system
- Cold start emission reduction strategy monitoring

### Sending Freeze Frame Data

- The Freeze Frame Data monitor items are shown below.

#### Freeze frame data monitor table

Full names	Unit	
DTC that caused required Freeze Frame Data storage	No unit	
Fuel system loop status	Refer to list below.	
LOAD	%	
ECT	°C	°F
Short term fuel trim	%	
Long term fuel trim	%	
MAP	kPa	
Engine speed	rpm	
Vehicle speed	km/h	mph
Spark advance	°	
IAT	°C	°F
MAF	g/s	
Absolute TP	%	
Time since engine start	s	
EGR valve control signal	%	
Purge solenoid valve control signal	%	
Fuel level	%	
Number of warm-ups since DTCs cleared	No unit	
Distance travelled since DTCs cleared	km	miles
Barometric pressure	kPa	
Estimated catalyst converter temperature	°C	°F
PCM voltage	V	
Absolute load value	%	
Theoretical air/fuel ratio coefficient to calculate target air/fuel ratio	No unit	
Relative TP	%	
Ambient air temperature	°C	°F
TP from TP sensor No.2	%	
APP from APP sensor No.1	%	
APP from APP sensor No.2	%	
Throttle actuator control signal	%	

### Meaning of fuel system loop status

- The following information is displayed on the tester.
  - Feedback stops: ECT is lower than the determined feedback zone.
  - Feedback operating: HO2S being used for feedback is normal.
  - Feedback stops: Open loop due to driving condition
  - Feedback stops: Open loop due to detected system fault
  - Feedback operating: Malfunction occurred in HO2S (rear) system

## ON-BOARD DIAGNOSTIC [LF]

### Sending Emission-related Malfunction Code

- The DTCs are shown below.

×: Applicable  
N/A: Not applicable

DTC No.		Condition	MIL	DC	Monitor item	Self-test type*3	Memory function
07MY	06MY						
B1342	←	PCM malfunction	OFF	N/A	N/A	C, O	N/A
P0011	←	CMP timing over-advanced	ON	1	CCM	C, R	×
P0012	←	CMP timing over-retarded	ON	2	CCM	C, R	×
P0016	←	CKP-CMP correlation	ON	2	CCM	C	×
P0030	←	Front HO2S heater control circuit problem	ON	2	HO2S heater	C, O, R	×
P0031	←	Front HO2S heater circuit low input	ON	2	HO2S heater	C, O, R	×
P0032	←	Front HO2S heater circuit high input	ON	2	HO2S heater	C, O, R	×
P0037	←	Rear HO2S heater circuit low input	ON	2	HO2S heater	C, O, R	×
P0038	←	Rear HO2S heater circuit high input	ON	2	HO2S heater	C, O, R	×
P0069	←	Manifold absolute pressure/atmospheric pressure correlation	ON	2	CCM	C	×
P0101	←	MAF sensor circuit range/performance problem	ON	2	CCM	C	×
P0102	←	MAF sensor circuit low input	ON	1	CCM	C, O, R	×
P0103	←	MAF sensor circuit high input	ON	1	CCM	C, O, R	×
P0107	←	MAP sensor circuit low input	ON	1	CCM	C, O, R	×
P0108	←	MAP sensor circuit high input	ON	1	CCM	C, O, R	×
P0111	←	IAT sensor circuit range/performance problem	ON	2	CCM	C	×
P0112	←	IAT sensor circuit low input	ON	1	CCM	C, O, R	×
P0113	←	IAT sensor circuit high input	ON	1	CCM	C, O, R	×
P0116	←	Engine coolant temperature circuit range/performance	ON	1	Engine cooling system	C	×
P0117	←	ECT sensor circuit low input	ON	1	Engine cooling system	C, O, R	×
P0118	←	ECT sensor circuit high input	ON	1	Engine cooling system	C, O, R	×
P0122	←	TP sensor No.1 circuit low input	ON	1	CCM	C, O, R	×
P0123	←	TP sensor No.1 circuit high input	ON	1	CCM	C, O, R	×
P0125	←	Excessive time to enter closed loop fuel control	ON	2	Engine cooling system	C	×
P0126	←	Coolant thermostat stuck open	ON	2	Engine cooling system	C	×
P0128	←		ON	2	Engine cooling system	C	×
P0130	←	Front HO2S circuit problem	ON	2	HO2S	C, O, R	×
P0131	←	Front HO2S circuit low input	ON	2	HO2S	C, O, R	×
P0132	←	Front HO2S circuit high input	ON	2	HO2S	C, O, R	×
P0133	←	Front HO2S circuit problem	ON	2	HO2S	C	×
P0134	←	Front HO2S no activity detected	ON	2	HO2S	C, R	×
P0137	←	Rear HO2S circuit low input	ON	2	HO2S	C, O, R	×
P0138	←	Rear HO2S circuit high input	ON	2	HO2S	C, O, R	×
P0139	←	Rear HO2S circuit problem	ON	2	HO2S	C	×
P0140	←	Rear HO2S no activity detected	ON	2	HO2S	C, R	×
P0222	←	TP sensor No.2 circuit low input	ON	1	CCM	C, O, R	×
P0223	←	TP sensor No.2 circuit high input	ON	1	CCM	C, O, R	×
P0300	←	Random misfire detected	Flash/ ON	1 or 2	Misfire	C, R	×
P0301	←	Cylinder No.1 misfire detected	Flash/ ON	1 or 2	Misfire	C, R	×

## ON-BOARD DIAGNOSTIC [LF]

DTC No.		Condition	MIL	DC	Monitor item	Self-test type*3	Memory function
07MY	06MY						
P0302	←	Cylinder No.2 misfire detected	Flash/ ON	1 or 2	Misfire	C, R	×
P0303	←	Cylinder No.3 misfire detected	Flash/ ON	1 or 2	Misfire	C, R	×
P0304	←	Cylinder No.4 misfire detected	Flash/ ON	1 or 2	Misfire	C, R	×
P0327	←	KS circuit low input	ON	1	CCM	C, O, R	×
P0328	←	KS circuit high input	ON	1	CCM	C, O, R	×
P0335	←	CKP sensor circuit problem	ON	1	CCM	C	×
P0340	←	CMP sensor circuit problem	ON	1	CCM	C	×
P0401	←	EGR flow insufficient detected	ON	2	EGR system	C, R	×
P0403	←	EGR valve (stepping motor) circuit problem	ON	2	CCM	C, O, R	×
P0421	←	Warm up catalyst system efficiency below threshold	ON	2	Catalyst	C	×
P0441	←	Evaporative emission control system incorrect purge flow	ON	2	Evaporative system	C, R	×
P0442	←	Evaporative emission control system leak detected (small leak)	ON	2	Evaporative system	C, R	×
P0443	←	Purge solenoid valve circuit problem	ON	2	CCM	C, O, R	×
P0446	←	Change over valve (COV) (EVAP system leak detection pump) stuck close	ON	2	CCM	C, R	×
P0455	←	Evaporative emission control system leak detected (gross leak)	ON	2	Evaporative system	C, R	×
P0456*1	←	Evaporative emission control system leak detected (very small leak)	ON	2	Evaporative system	C, R	×
P0461	←	Fuel gauge sender unit range/performance problem	ON	2	CCM	C	×
P0462	←	Fuel gauge sender unit circuit low input	ON	2	CCM	C, O, R	×
P0463	←	Fuel gauge sender unit circuit high input	ON	2	CCM	C, O, R	×
P0480	←	Cooling fan relay No.1 control circuit malfunction	OFF	1	Other	C, O, R	×
P0481	←	Cooling fan relay No.2 control circuit malfunction	OFF	1	Other	C, O, R	×
P0482	←	Cooling fan relay No.3 control circuit malfunction	OFF	1	Other	C, O, R	×
P0500*4	←	VSS circuit problem	ON	2	CCM	C	×
P0505	←	Idle speed control system problem	OFF	N/A	N/A	R	N/A
P0506	←	Idle speed control system RPM lower than expected	ON	2	CCM	C	×
P0507	←	Idle speed control system RPM higher than expected	ON	2	CCM	C	×
P050A	N/A	Cold start idle air control system performance	ON	2	Cold start emission reduction strategy monitoring	C, R	×
P050B	N/A	Cold start ignition timing performance	ON	2	Cold start emission reduction strategy monitoring	C, R	×
P0550	←	PSP switch circuit malfunction	ON	2	CCM	C	×
P0564	←	Cruise control switch circuit malfunction	OFF	1	Other	C	×
P0571	←	Brake switch circuit problem	OFF	1	Other	C	×
P0601	←	PCM memory check sum error	ON	1	CCM	C, O, R	×
P0602	←	PCM programming error	ON	1	CCM	C, O, R	×

## ON-BOARD DIAGNOSTIC [LF]

DTC No.		Condition	MIL	DC	Monitor item	Self-test type*3	Memory function
07MY	06MY						
P0604	←	PCM random access memory (RAM) error	ON	1	CCM	C, O, R	×
P0606	←	PCM processor	ON	1	CCM	C, O, R	×
P0610	←	PCM vehicle options error	ON	1	CCM	C, O, R	×
P0638	←	Throttle actuator control circuit range/performance problem	ON	1	CCM	C	×
P0661	←	Variable intake air solenoid valve circuit low input	OFF	1	Other	C, O, R	×
P0662	←	Variable intake air solenoid valve circuit high input	OFF	1	Other	C, O, R	×
P0703	←	Brake switch input circuit problem	ON	2	CCM	C	×
P0704*2	←	Clutch pedal position (CPP) switch input circuit problem	ON	2	CCM	C	×
P0850*2	←	Neutral switch input circuit problem	ON	2	CCM	C	×
P1260	←	Immobilizer system problem	OFF	1	Other	C, O	N/A
P2088	←	Oil control valve (OCV) circuit low	ON	1	CCM	C, O, R	×
P2089	←	Oil control valve (OCV) circuit high	ON	1	CCM	C, O, R	×
P2096	←	Target A/F feedback system too lean	ON	2	Fuel system	C	×
P2097	←	Target A/F feedback system too rich	ON	2	Fuel system	C	×
P2101	←	Throttle actuator circuit range/performance	ON	1	CCM	C, R	×
P2107	←	Throttle actuator control module processor error	ON	1	CCM	C, R	×
P2108	←	Throttle actuator control module performance error	ON	1	CCM	C, R	×
P2109	←	TP sensor minimum stop range/performance problem	ON	1	CCM	C, R	×
P2112	←	Throttle actuator control system range/performance problem	ON	1	CCM	C, R	×
P2119	←	Throttle actuator control throttle body range/performance problem	ON	2	CCM	C, R	×
P2122	←	APP sensor No.1 circuit low input	ON	1	CCM	C, O, R	×
P2123	←	APP sensor No.1 circuit high input	ON	1	CCM	C, O, R	×
P2127	←	APP sensor No.2 circuit low input	ON	1	CCM	C, O, R	×
P2128	←	APP sensor No.2 circuit high input	ON	1	CCM	C, O, R	×
P2135	←	TP sensor No.1/No.2 voltage correlation problem	ON	1	CCM	C, O, R	×
P2138	←	APP sensor No.1/No.2 voltage correlation problem	ON	1	CCM	C, O, R	×
P2177	←	Fuel system too lean at off idle	ON	2	Fuel system	C, R	×
P2178	←	Fuel system too rich at off idle	ON	2	Fuel system	C, R	×
P2187	←	Fuel system too lean at idle	ON	2	Fuel system	C, R	×
P2188	←	Fuel system too rich at idle	ON	2	Fuel system	C, R	×
P2195	←	Front HO2S signal stuck lean	ON	2	HO2S	C	×
P2196	←	Front HO2S signal stuck rich	ON	2	HO2S	C	×
P2228	←	BARO sensor circuit low input	ON	1	CCM	C, O, R	×
P2229	←	BARO sensor circuit high input	ON	1	CCM	C, O, R	×
P2401	←	EVAP system leak detection pump motor circuit low	ON	2	CCM	C, R	×
P2402	←	EVAP system leak detection pump motor circuit high	ON	2	CCM	C, R	×
P2404	←	EVAP system leak detection pump sense circuit problem	ON	2	CCM	C, R	×
P2405	←	EVAP system leak detection pump sense circuit low input	ON	2	CCM	C, R	×
P2407	←	EVAP system leak detection pump sense circuit intermittent	ON	2	CCM	C, R	×

## ON-BOARD DIAGNOSTIC [LF]

DTC No.		Condition	MIL	DC	Monitor item	Self-test type*3	Memory function
07MY	06MY						
P2502	←	Charging system voltage problem	OFF	1	Other	C, R	×
P2503	←	Charging system voltage low	OFF	1	Other	C, R	×
P2504	←	Charging system voltage high	OFF	1	Other	C, R	×
P2507	←	PCM B+ voltage low	ON	1	CCM	C, O, R	×
P2610	←	PCM internal engine off timer performance	ON	2	CCM	C	×

\*1 : California emission regulation applicable model

\*2 : MT

\*3 : C: CMDTC self-test, O: KOEO self-test, R: KOER self-test

\*4 : With ABS/DSC or MT without ABS/DSC

### Sending Intermittent Monitoring System Test Results

- The items supported by the sending intermittent monitoring system are shown below.

TEST ID	Description	Related system
10:01:80	HO2S (Front) lean-to-rich response time (calculated)	HO2S
10:01:81	HO2S (Front) rich-to-lean response time (calculated)	
10:01:82	HO2S (Front) lean-to-rich response time (calculated)	
10:01:83	HO2S (Front) rich-to-lean response time (calculated)	
10:02:03	Low HO2S (Rear) voltage for switch time calculation (constant)	
10:02:04	High HO2S (Rear) voltage for switch time calculation (constant)	
10:02:05	HO2S (Rear) rich-to-lean response time (calculated)	
10:21:80	HO2S (Front) and HO2S (Rear) switching time ratio	
10:31:83	EGR pressure variation	EGR
10:3A:80	EVAP system leak detection pump large leak check	EVAP
10:3B:80	EVAP system leak detection pump small leak check	
10:3C:80*1	EVAP system leak detection pump very small leak check	
10:3D:80	Purge flow monitor	
10:A2:0B	Cylinder No.1 average misfire counts for last 10 DC	Misfire
10:A2:0C	Cylinder No.1 misfire counts for last/current DC	
10:A3:0B	Cylinder No.2 average misfire counts for last 10 DC	
10:A3:0C	Cylinder No.2 misfire counts for last/current DC	
10:A4:0B	Cylinder No.3 average misfire counts for last 10 DC	
10:A4:0C	Cylinder No.3 misfire counts for last/current DC	
10:A5:0B	Cylinder No.4 average misfire counts for last 10 DC	
10:A5:0C	Cylinder No.4 misfire counts for last/current DC	
10:E1:80	Heat radiation ratio	Thermostat
10:E1:81	Engine coolant temperature	

\*1 : California emission regulation applicable model

### Sending Continuous Monitoring System Test Results

- These appear when a problem is detected in a monitored system.

#### 1-drive cycle type

- If any problems are detected in the first drive cycle, pending codes will be stored in the PCM memory, as well as DTCs.
- After pending codes are stored, if the PCM determines that the system is normal in any future drive cycle, the PCM deletes the pending codes.

## ON-BOARD DIAGNOSTIC [LF]

### 2-drive cycle type

- The code for a failed system is stored in the PCM memory in the first drive cycle. If the problem is not found in the second drive cycle, the PCM determines that the system returned to normal or the problem was mistakenly detected, and deletes the pending code when the ignition switch is turned to the ON position in the next drive cycle. If the problem is found in the second drive cycle too, the PCM determines that the system has failed, and stores the pending codes, and the DTCs.
- After pending codes are stored, if the PCM determines that the system is normal in any future drive cycle, the PCM deletes the pending codes.

### DLC-2 Outline

- The DLC-2 located in the driver compartment is a service connector defined by OBD-II regulations.
- The following are functions for each terminal.

Terminal name	Function
B+	Battery positive voltage
CAN_L	Serial communication Lo terminal
CAN_H	Serial communication Hi terminal
GND1	Ground (chassis)
GND2	Ground (signal)

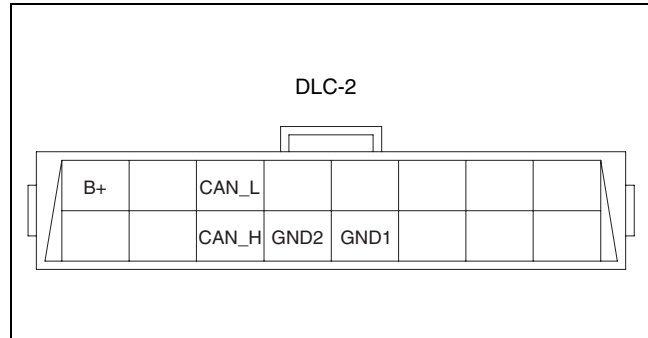

amxuun000001

### DTC DETECTION LOGIC AND CONDITIONS[LF]

id010245100300

#### B1342 PCM malfunction

- Malfunction in the PCM internal circuit.

#### P0011 CMP Timing over-advanced

- The actual valve timing is over-advanced by **15 °** from the target valve timing for specified period when the oil control valve (OCV) is controlled in the maximum valve timing retard condition.

##### Monitoring condition

- Engine coolant temperature is **above 63 °C {145.4 °F}**

#### P0012 CMP timing over-retarded

- Actual valve timing is over-retarded by **10 °** from the target valve timing for specified period when the oil control valve (OCV) system control is within the feedback range.

##### Monitoring condition

- Engine coolant temperature is **above 63 °C {145.4 °F}**

#### P0016 CKP-CMP correlation

- The PCM monitors the input pulses from the CKP sensor and CMP sensor. If the input pulse pick-up timing do not match each other, the PCM determines that the camshaft position does not coincide with the crankshaft position.

#### P0030 Front HO2S heater control circuit problem

- The PCM monitors the front HO2S impedance when under the front HO2S heater control for **200 s**. If the impedance is **more than 44 ohms**, the PCM determines that there is a front HO2S heater control circuit problem.

#### P0031 Front HO2S heater circuit low input

- The PCM monitors the front HO2S heater control voltage when the PCM turns the front HO2S heater off. If the control voltage **exceeds 50%** of the battery voltage, the PCM determines that the front HO2S heater control circuit voltage is low.

#### P0032 Front HO2S heater circuit high input

- The PCM monitors the front HO2S heater control voltage when the PCM turns the front HO2S heater on. If the control voltage is **less than 50%** of the battery voltage, the PCM determines that the front HO2S heater control circuit voltage is high.

#### P0037 Rear HO2S heater circuit low input

- The PCM monitors the rear HO2S heater control voltage when the PCM turns the rear HO2S heater off. If the control voltage **exceeds 25%** of the battery voltage, the PCM determines that the rear HO2S heater control circuit voltage is low.

#### P0038 Rear HO2S heater circuit high input

- The PCM monitors the rear HO2S heater control voltage when the PCM turns the rear HO2S heater on. If the control voltage is **less than 57%** of the battery voltage, the PCM determines that the rear HO2S heater control circuit voltage is high.

## P0069 Manifold absolute pressure/atmospheric pressure correlation

- PCM monitors differences between intake manifold vacuum and atmospheric pressure. If the difference is **below -12 kPa {-90 mmHg, -3.5 inHg}** or **above 12 kPa {90 mmHg, 3.5 inHg}** when the following conditions are met, the PCM determines that there is a MAP sensor performance problem.

### MONITORING CONDITION

- **12—15 s** from when ignition switch is turned off.
- Intake air temperature is **above -10°C {14 °F}**.
- Engine coolant temperature is **above 70°C {158°F}**.

## P0101 MAF sensor circuit range/performance problem

- PCM monitors mass intake air flow amount when the engine is running.
  - If the mass intake air flow amount is **above 37 l/s** for 5 s and the engine speed is below 2,000 rpm with the engine running, the PCM determines that the detected mass intake air flow amount is too high.
  - If the mass intake air flow amount is **below 4.4—59 l/s** (The value depends on engine speed.) for **5 s** and the engine speed is **above 1,000 rpm** with the engine running and the throttle opening angle **above 50 %**, the PCM determines that detected the mass intake air flow amount is too low.

## P0102 MAF sensor circuit low input

- The PCM monitors input voltage from the MAF sensor when the engine running. If the input voltage is **below 0.21 V**, the PCM determines that the MAF circuit has a malfunction.

## P0103 MAF sensor circuit high input

- The PCM monitors the input voltage from the MAF sensor when the engine running. If the input voltage is **above 4.9 V**, the PCM determines that the MAF circuit has a malfunction.

## P0107 MAP sensor circuit low input

- The PCM monitors the input voltage from the MAP sensor when intake air temperature is **above -10 °C {14 °F}**. If the input voltage is **below 0.1 V**, the PCM determines that the MAP sensor circuit has a malfunction.

### MONITORING CONDITIONS

- Calculated load: **13—32 %**

## P0108 MAP sensor circuit high input

- The PCM monitors the input voltage from the MAP sensor when intake air temperature is **above -10 °C {14 °F}**. If input the voltage is **above 4.9 V**, the PCM determines that the MAP sensor circuit has a malfunction.

### MONITORING CONDITIONS

- Calculated load: **13—32 %**

## P0111 IAT sensor circuit range/performance problem

- If intake air temperature is higher than engine coolant temperature by **18 °C {32.4 °F}** for **1.2 s** with ignition switch on\*, the PCM determines that there is a intake air temperature sensor circuit range/performance problem.

\*: Ignition switch on when **6 h** or more has passed since the previous ignition switch off

## P0112 IAT sensor circuit low input

- The PCM monitors the IAT sensor signal. If the PCM detects that the IAT sensor voltage is **below 0.16 V**, the PCM determines that the IAT sensor circuit has a malfunction.

## P0113 IAT sensor circuit high input

- The PCM monitors the IAT sensor signal. If the PCM detects that the IAT sensor voltage is **above 4.84 V**, the PCM determines that IAT sensor circuit has a malfunction.

## P0116 Engine coolant temperature circuit range/performance

- The PCM monitors the maximum value and minimum value of engine coolant temperature when the engine is started and **5 min** have been passed after leaving the vehicle **6 h or more**. If difference between maximum and minimum values of engine coolant temperature is **below 6 °C {10.8 °F}** the PCM determines that there is an ECT circuit range/performance problem.

## P0117 ECT sensor circuit low input

- The PCM monitors the ECT sensor signal at PCM terminal 2AH. If the PCM detects the ECT sensor voltage **below 0.2 V**, the PCM determines that the ECT sensor circuit has malfunction.

## P0118 ECT sensor circuit high input

- The PCM monitors the ECT sensor signal at PCM terminal 2AH. If the PCM detects the ECT sensor voltage is **above 4.58 V**, the PCM determines that the ECT sensor circuit has malfunction.

## P0122 TP sensor No.1 circuit low input

- If the PCM detects that the TP sensor No.1 voltage is **below 0.1 V** while the engine is running, the PCM determines that the TP sensor No.1 circuit has a malfunction.

## P0123 TP sensor No.1 circuit high input

- If the PCM detects the TP sensor No.1 voltage is to be **above 4.9 V** after ignition switch to the ON position, PCM determines that TP sensor No.1 circuit has a malfunction.

## P0125 Excessive time to enter closed loop fuel control

- The PCM monitors the ECT sensor signal at PCM terminal 2AH after engine is started while the engine is cold. If the engine coolant temperature does not reach the expected temperature for specified period, the PCM determines that it has taken an excessive amount of time for the engine coolant temperature to reach the temperature necessary to start closed-loop fuel control.

## ON-BOARD DIAGNOSTIC [LF]

### P0126 Coolant thermostat stuck open

- If the ECT signal never exceeds **71 °C {160 °F}** after engine start for specified period, PCM determines that the coolant thermostat is stuck open.

#### MONITORING CONDITIONS

- IAT: **above -10 °C {14 °F}**
- Vehicle speed: **over 6 km/h {3.7 mph}**

### P0128 Coolant thermostat stuck open

- PCM monitors MAF, IAT, VSS and EAT signals and calculate radiator's heat radiation ratio while following monitoring conditions are met. If calculated value exceeds threshold, PCM determines that the coolant thermostat is stuck open.

#### MONITORING CONDITIONS

- IAT: **above -10°C {14 °F}**
- ECT at engine start: **below 36 °C {97 °F}**
- Difference between ECT at engine start and minimum IAT: **below 6 °C {10.8 °F}**
- Vehicle speed: **over 30 km/h {18.6 mph}**

### P0130 Front HO2S circuit problem

- The PCM monitors the front HO2S impedance when under the front HO2S heater control. If the impedance is **more than 500 ohms**, the PCM determines that there is a front HO2S circuit problem.

### P0131 Front HO2S circuit low input

- The PCM monitors the input voltage from the front HO2S and the front HO2S output current when the engine is running. If the input voltage is **less than 1.8 V** or the output current is **less than -5 mA**, the PCM determines that the front HO2S circuit voltage is low.

### P0132 Front HO2S circuit high input

- The PCM monitors the input voltage from the front HO2S and the front HO2S output current when the engine is running. If the input voltage is **more than 3.8 V** or the output current is **more than 5 mA**, the PCM determines that the front HO2S circuit voltage is high.

### P0133 Front HO2S circuit problem

- The PCM monitors the peak differential value of oxygen sensor signal after A/F fluctuation being provided when the following conditions are met. If the peak differential value is lower than the threshold value.
- The PCM determines that front HO2S circuit is slow.

#### MONITORING CONDITIONS

- HO2S heater, HO2S, and TWC Repair Verification Drive Mode
- Following conditions are met:
  - Front HO2S heater monitor is completed.
  - Fuel system loop status is closed loop fuel control.
- Engine speed: **1,750—3,500 rpm**
- Charging efficiency: **25—63 %** (at engine speed: **2,500 rpm**)
- Intake air volume: **5—40 g/s**
- Engine coolant temperature **above 70 °C {158 °F}**

### P0134 Front HO2S no activity detected

- The PCM monitors the front HO2S element impedance when the following conditions are met. If the front HO2S element impedance is **80 ohms** or more, the PCM determines that front HO2S is not activated.

#### MONITORING CONDITIONS

- HO2S, HO2S heater and TWC Repair Verification Drive Mode
- Following conditions are met
  - Time from engine start is **above 30 s** (ECT when engine start is **20 °C {68 °F}**).

### P0137 Rear HO2S circuit low input

- The PCM monitors input voltage from rear HO2S. If the input voltage from the rear HO2S is below **0.1 V** for **35.2 s** the PCM determines that circuit input is low.

#### MONITORING CONDITIONS

- HO2S, HO2S heater and TWC repair verification drive mode
- Following conditions are met.
  - Engine speed is **above 1,500 rpm**.
  - Engine coolant temperature is **above 70 °C {158 °F}**.
  - Fuel injector control in rear HO2S closed loop control.
- The PCM monitors the input voltage from the rear HO2S when the following conditions are met. Under the following monitoring conditions, if the input voltage from the rear HO2S does not even **exceed 0.1 V** though the short term fuel trim is controlled up to **20.5 %** for **9.6 s**, the PCM determines that sensor circuit input is low.

#### MONITORING CONDITIONS

- HO2S, HO2S heater and TWC repair verification drive mode
- Following conditions are met for **above 20.8 s**.
  - Engine speed is **above 1,500 rpm**.
  - Engine coolant temperature is **above 70 °C {158 °F}**.

### P0138 Rear HO2S circuit high input

- The PCM monitors input voltage from rear HO2S. If the input voltage from the rear HO2S sensor is **above 1.2 V** for **0.8 s**, the PCM determines that circuit input is high.

### P0139 Rear HO2S circuit problem

- The PCM monitors the rich (**0.4 V**) to lean (**0.3 V**) response time of the rear HO2S. The PCM measures the response time when the following conditions are met. The PCM determines a rear HO2S response deterioration malfunction when the measured response time is more than the threshold value (**80 ms**) five consecutive times.

#### MONITORING CONDITIONS

— PCM Adaptive Memory Production, HO2S heater, HO2S, and TWC Repair Verification Drive Mode

— Following conditions are met:

- During deceleration fuel cut
- Engine speed is **above 500 rpm**.
- Engine coolant temperature is **above 70 °C {158 °F}**.
- Rear HO2S output voltage is **above 0.4 V**.

- The PCM monitors for a time-out malfunction (when rear HO2S remains **above 0.3 V** for longer than a specified period of time during fuel cut control). The PCM measures the amount of time from when the following conditions are met until the rear HO2S output voltage drops **below 0.3 V**. The PCM determines a rear HO2S time-out malfunction when the detected time is more than the threshold value (**6 s**) three consecutive times.

#### MONITORING CONDITIONS

— PCM Adaptive Memory Production, HO2S heater, HO2S, and TWC Repair Verification Drive Mode

— Following conditions are met:

- During deceleration fuel cut
- Engine speed is **above 500 rpm**.
- Engine coolant temperature is **above 70 °C {158 °F}**.
- Rear HO2S is activated (**more than 0.55 V**)

### P0140 Rear HO2S no activity detected

- The PCM monitors the input voltage from the rear HO2S when the following conditions are met. Under the following monitoring conditions, if the input voltage from the rear HO2S does not even **exceed 0.55 V** though the short term fuel trim is controlled up to **20.5%** for **9.6 s**, the PCM determines that sensor circuit is not activated.

#### MONITORING CONDITIONS

— HO2S, HO2S heater and TWC repair verification drive mode

— Following conditions are met for **above 20.8 s**

- Engine speed is **above 1,500 rpm**.
- Engine coolant temperature is **above 70 °C {158 °F}**.

— Rear HO2S voltage is **above 0.1 V**

### P0222 TP sensor No.2 circuit low input

- If PCM detects TP sensor No.2 voltage is to be **below 0.1 V** after the ignition switch to the ON position, the PCM determines that TP circuit has a malfunction.

### P0223 TP sensor No.2 circuit high input

- If the PCM detects the TP sensor No.2 voltage is to be **above 4.9 V** after the ignition switch to the ON position, the PCM determines that the TP circuit has a malfunction.

### P0300 Random misfire detected

- The PCM monitors CKP sensor input signal interval time. The PCM calculates change of interval time for each cylinder. If change of interval time exceeds preprogrammed criteria, the PCM detects misfire in the corresponding cylinder. While the engine is running, the PCM counts number of misfires that occurred at **200 crankshaft revolutions** and **1,000 crankshaft revolutions** and calculates misfire ratio for each crankshaft revolution. If the ratio exceeds the preprogrammed criteria, the PCM determines that a misfire, which can damage catalytic converter or affect emission performance, has occurred.

### P0301, P0302, P0303, P0304 Cylinder No.1, No.2, No.3, No.4 misfire detected

- The PCM monitors CKP sensor input signal interval time. The PCM calculates the change of interval time for each cylinder. If the change of interval time exceeds the preprogrammed criteria, the PCM detects a misfire in the corresponding cylinder. While the engine is running, the PCM counts number of misfires that occurred at **200 crankshaft revolutions** and **1,000 crankshaft revolutions** and calculates misfire ratio for each crankshaft revolution. If the ratio exceeds the preprogrammed criteria, the PCM determines that a misfire, which can damage catalytic converter or affect emission performance, has occurred.

### P0327 KS circuit low input

- The PCM monitors input signal from the KS when the engine is running. If the input voltage is **below 0.01 V** the PCM determines that the KS circuit has a malfunction.

### P0328 KS circuit high input

- The PCM monitors the input signal from the KS when the engine is running. If the input voltage is **above 4.58 V** the PCM determines that KS circuit has a malfunction.

## ON-BOARD DIAGNOSTIC [LF]

---

### **P0335 CKP sensor circuit problem**

- If the PCM does not receive the input voltage from the CKP sensor for **4.2 s** while the MAF is **1.95 g/s {0.25 lb/min.} or above**, the PCM determines that the CKP sensor circuit has a malfunction.
- If a malfunction is detected in the input pulse pattern from the CKP sensor.

### **P0340 CMP sensor circuit problem**

- The PCM monitors the input voltage from the CMP sensor when the engine is running. If the PCM does not receive the input voltage from the CMP sensor while the PCM receives the input signal from the CKP sensor, the PCM determines that the CMP circuit has a malfunction.
- If a malfunction is detected in the input pulse pattern from the CMP sensor.

### **P0401 EGR flow insufficient detected**

- PCM monitors difference in intake manifold pressures when EGR is operated and when it is stopped. If the difference is too small, PCM determines that EGR flow insufficient.

### **P0403 EGR valve (stepping motor) circuit problem**

- The PCM monitors the EGR valve control signal voltage and current. If the following conditions are met, the PCM determines that there is the EGR control circuit problem.
  - The PCM turns the EGR valve off, but the voltage of the EGR valve control signal remains low.
  - The PCM turns the EGR valve on, but the current of the EGR valve control signal remains high.

### **P0421 Warm up catalyst system efficiency below threshold**

- PCM compares number of front HO<sub>2</sub>S and rear HO<sub>2</sub>S inversions for a predetermined time. PCM monitors number of inversions rear side performs while front side inverts for a specified number of times when the following monitoring conditions are met, PCM detects inversion ratio. If inversion ratio is below threshold, PCM determines that catalyst has deteriorated.

#### **MONITORING CONDITION**

- Calculated TWC temperature: **more than 400 °C {752 °F}**
- Engine speed: **1,500—3,000 rpm**
- LOAD: **15—48 %** (at engine speed 2,000 rpm)

### **P0441 Evaporative emission control system incorrect purge flow**

- PCM measures the purge line pressure, which is the vacuum when a following condition. If vacuum between charcoal canister and intake manifold does not reach the specified, PCM determines that the EVAP system has clogging.

#### **MONITORING CONDITION**

- Engine speed: **1,500—3,500 rpm**
- Throttle opening angle: **11—20 %**
- Vehicle speed: **69.5—136 km/h {43.2—84.5 mph} [MT]/34.5—136 km/h {21.4—84.5 mph} [AT]**

### **P0442 Evaporative emission control system leak detected (small leak)**

- PCM measures the pump load current (EVAP line pressure) when the specified period has passed after EVAP system is sealed when monitoring conditions are met. If the load does not reach the reference current value within the specified period, PCM determines that the EVAP system has small leak.

#### **MONITORING CONDITION**

- The ignition switch is turned off.
- IAT: **4.4—35 °C {40—95 °F}**
- Battery voltage: **11 V or above**
- Atmospheric pressure: **72.2 kPa {542 mmHg, 21.3 inHg} or above**
- Fuel tank level: **15—85%**
- Time from engine off: **5 h 10 min.**

### **P0443 Purge solenoid valve circuit problem**

- The PCM monitors the purge solenoid valve control signal voltage and current. If the following conditions are met, the PCM determines that there is the purge solenoid valve control circuit problem.
  - The PCM turns the purge solenoid valve off, but the voltage of the purge solenoid valve control signal remains low.
  - The PCM turns the purge solenoid valve on, but the current of the purge solenoid valve control signal remains high.

### **P0446 Change over valve (COV) (EVAP system leak detection pump) stuck close**

- The PCM monitors pump load current (EVAP line pressure), while evaporative leak monitor is operating. When the decrease in pump load current is less than the specification after the reference current value has been obtained, the PCM determines change over valve (COV) in EVAP system leak detection pump has a malfunction.

### **P0455 Evaporative emission control system leak detected (gross leak)**

- PCM measures the pump load current (EVAP line pressure) when the specified period has passed after EVAP system is sealed when monitoring conditions are met. If the load does not reach the reference current value within the specified period, PCM determines that the EVAP system has gross leak.

#### **MONITORING CONDITION**

- The ignition switch is turned off.
- IAT: **4.4—35 °C {40—95 °F}**
- Battery voltage: **11 V or above**
- Atmospheric pressure: **72.2 kPa {542 mmHg, 21.3 inHg} or above**
- Fuel tank level: **15—85%**
- Time from engine off: **5 h 10 min.**

### **P0456 Evaporative emission control system leak detected (very small leak)**

- PCM measure the pump load current (EVAP line pressure) when a specified period has passed after EVAP system is sealed when monitoring conditions are met. If the load does not reach the reference load value or rate of the load increase lower than the specified within a specified period, PCM determines that the EVAP system has very small leak.

#### **MONITORING CONDITION**

- The ignition switch is turned off.
- IAT: **4.4—35 °C {40—95 °F}**
- Battery voltage: **11 V or above**
- Atmospheric pressure: **72.2 kPa {542 mmHg, 21.3 inHg} or above**
- Fuel tank level: **15—85%**
- Time from engine off: **5 h 10 min.**

### **P0461 Fuel gauge sender unit range/performance problem**

- The PCM monitors the fuel tank level difference before and after the PCM-calculated fuel consumption has reached **more than 25 L {26.4 US qt, 22 Imp qt}**. If the difference is **less than 5%**, the PCM determines that there is a fuel gauge sender unit range/performance problem.

### **P0462 Fuel gauge sender unit circuit low input**

- The PCM monitors the fuel level signal and fuel gauge sender unit output voltage from the instrument cluster. If the PCM detects a fuel level or fuel gauge sender unit output voltage is too low, the PCM determines that the fuel gauge sender unit circuit has a malfunction.

### **P0463 Fuel gauge sender unit circuit high input**

- The PCM monitors the fuel level signal and fuel gauge sender unit output voltage from the instrument cluster. If the PCM detects a fuel level or fuel gauge sender unit output voltage is too high, the PCM determines that the fuel gauge sender unit circuit has a malfunction.

### **P0480 Cooling fan relay No.1 control circuit malfunction**

- The PCM monitors the cooling fan relay No.1 control signal voltage and current. If the following conditions are met, the PCM determines that there is the cooling fan relay No.1 control circuit problem.
  - The PCM turns the cooling fan relay No.1 off, but the voltage of the cooling fan relay No.1 control signal remains low.
  - The PCM turns the cooling fan relay No.1 on, but the current of the cooling fan relay No.1 control signal remains high.

### **P0481 Cooling fan relay No.2 control circuit malfunction**

- The PCM monitors the cooling fan relay No.2 control signal voltage and current. If the following conditions are met, the PCM determines that there is the cooling fan relay No.2 control circuit problem.
  - The PCM turns the cooling fan relay No.2 off, but the voltage of the cooling fan relay No.2 control signal remains low.
  - The PCM turns the cooling fan relay No.2 on, but the current of the cooling fan relay No.2 control signal remains high.

### **P0482 Cooling fan relay No.3 control circuit malfunction**

- The PCM monitors the cooling fan relay No.3 control signal voltage and current. If the following conditions are met, the PCM determines that there is the cooling fan relay No.3 control circuit problem.
  - The PCM turns the cooling fan relay No.3 off, but the voltage of the cooling fan relay No.3 control signal remains low.
  - The PCM turns the cooling fan relay No.3 on, but the current of the cooling fan relay No.3 control signal remains high.

## ON-BOARD DIAGNOSTIC [LF]

---

### **P0500 VSS circuit problem**

#### **With ABS/DSC**

- If an error in the wheel speed signal from the ABS/DSC HU/CM is detected by CAN when the following conditions are met:
  - Neutral switch and clutch pedal position switch are OFF
  - Load is **above 40 %**
  - Engine speed is **2,000 rpm or above**
  - Brake switch is OFF
  - Shift lever position (P, N, R position) (AT)

#### **MT without ABS/DSC**

- Vehicle speed signal from vehicle speed sensor is **below 3.7 km/h {2.3 mph}** when the following conditions are met:
  - Neutral switch and clutch pedal position switch are OFF
  - Load is **above 40 %**
  - Engine speed is **2,000 rpm or above**
  - Brake switch is OFF

### **P0505 Idle speed control system problem**

- The PCM cannot control idle speed toward target idle speed while KOER self test.

### **P0506 Idle speed control system RPM lower than expected**

- Actual idle speed is lower than expected by **100 rpm for 14 s**, when brake pedal is depressed (brake switch is on) and steering wheel is held straight ahead (power steering pressure (PSP) switch is off).

### **P0507 Idle speed control system RPM higher than expected**

- Actual idle speed is higher than expected by **200 rpm for 14 s**, when the brake pedal is depressed (brake switch is on) and steering wheel is held straight ahead (power steering pressure (PSP) switch is off).

### **P050A Cold start idle air control system performance**

- Actual idle speed is lower than expected by **100 rpm for 8.4 s** when the target idle speed correction value for cold start is **above 0 rpm** or ignition retard value is **above 10 ° CA**.

#### **Note**

- If atmospheric pressure is **less than 72.3 kPa {542 mmHg, 21.3 inHg}** or intake air temperature is **below -10 °C {14 °F}**, the PCM cancels diagnosis of P050A.

### **P050B Cold start ignition timing performance**

- The PCM monitors actual ignition timing using the CKP sensor while electronic spark advance control fast idle correction operating. If the ignition timing is out of specified range, the PCM determines that the ignition timing at cold condition has performance problem.

### **P0550 PSP switch circuit malfunction**

- The PCM monitors PSP switch signal at PCM terminal 2T. If input voltage is low voltage (switch stays on) for **1 min.** when the VSS is **above 60.0 km/h {37.4 mph}** and ECT is **above 60 °C {140 °F}**, the PCM determines that PSP switch circuit has malfunction.

### **P0564 Cruise control switch circuit malfunction**

- The PCM monitors the cruise control switch signal at PCM terminal 1AQ. If the PCM detects that any one of following switches (ON OFF, SET/-, SET/COAST, RES/+) remains on for **2 min**, the PCM determines that the cruise control switch circuit has a malfunction.

### **P0571 Brake switch circuit problem**

- The PCM monitors changes in input voltage for brake switch No.1 and No.2. If the PCM detects that both brake switches No.1 and No.2 remain on or off for **15 s**, it determines that the brake switch circuit has a malfunction.

### **P0601 PCM memory check sum error**

- PCM internal memory check sum error

### **P0602 PCM programming error**

- No configuration data in the PCM

### **P0604 PCM random access memory (RAM) error**

- PCM internal RAM malfunction.

### **P0606 PCM processor**

- The PCM internal CPU malfunction

### **P0610 PCM vehicle options error**

- PCM data configuration error

### **P0638 Throttle actuator control circuit range/performance problem**

- The PCM compares the actual TP with the target TP when the engine is running. If the difference is more than the specification, the PCM determines that there is a throttle actuator control circuit range/performance problem.

### **P0661 Variable intake air solenoid valve circuit low input**

- The PCM monitors the variable intake air solenoid valve control signal. If the PCM turns variable intake air solenoid valve off but voltage at PCM terminal still remains low, the PCM determines that variable intake air solenoid valve circuit has malfunction.

### **P0662 Variable intake air solenoid valve circuit high input**

- The PCM monitors the variable intake air solenoid valve control signal at PCM terminal. If the PCM turns variable intake air solenoid valve on but voltage at PCM terminal still remains high, the PCM determines that the variable intake air solenoid valve circuit has malfunction.

### **P0703 Brake switch input circuit problem**

- The PCM monitors changes in input voltage from the brake switch No.1. If the PCM does not the voltage changes while alternately accelerating and decelerating **8 times**, the PCM determines that the brake switch No.1 circuit has a malfunction.

### **P0704 Clutch pedal position (CPP) switch input circuit problem**

- The PCM monitors changes in input voltage from the CPP switch. If the PCM does not detect the voltage changes while the vehicle runs with vehicle speed **above 30 km/h {19 mph}** and stops **8 times** alternately, the PCM determines that the CPP switch circuit has a malfunction.

### **P0850 Neutral switch input circuit problem**

- The PCM monitors changes in input voltage from the neutral switch. If the PCM does not detect the voltage changes while driving the vehicle at a vehicle speed **above 30 km/h {19 mph}** and clutch pedal turns press and depress **10 times** repeatedly, the PCM determines that the neutral switch circuit has a malfunction

### **P1260 Immobilizer system problem**

- The instrument cluster detects an immobilizer system malfunction.

### **P2088 Oil control valve (OCV) circuit low**

- The PCM monitors the OCV voltage. If the PCM detects the OCV control voltage (calculated from the OCV) is below the threshold voltage (calculated from the battery positive voltage), the PCM determines that the OCV circuit has a malfunction.

### **P2089 Oil control valve (OCV) circuit high**

- The PCM monitors the OCV voltage. If the PCM detects that the OCV control voltage (calculated from the OCV) is above the threshold voltage (calculated from battery positive voltage), the PCM determines that the OCV circuit has a malfunction.

### **P2096 Target A/F feedback system too lean**

- The PCM monitors the target A/F fuel trim when under the target A/F feedback control. If the fuel trim is more than the specification, the PCM determines that the target A/F feedback system is too lean.

#### **MONITORING CONDITION**

— Rear HO2S voltage is **above 0.1 V**

### **P2097 Target A/F feedback system too rich**

- The PCM monitors the target A/F fuel trim when under the target A/F feedback control. If the fuel trim is less than specification, the PCM determines that the target A/F feedback system is too rich.

### **P2101 Throttle actuator circuit range/performance**

- The PCM monitors the input voltage from the drive-by-wire relay when the PCM turns the drive-by-wire relay on. If the input voltage is **less than 5.0 V**, the PCM determines that the drive-by-wire relay control circuit voltage is low.
- The PCM monitors the input voltage from the drive-by-wire relay when the PCM turns the drive-by-wire relay off. If the input voltage is **more than 5.0 V** the PCM determines that the drive-by-wire relay control circuit voltage is high.

### **P2107 Throttle actuator control module processor error**

- Throttle actuator control module internal processor error

### **P2108 Throttle actuator control module performance error**

- PCM internal malfunction.

### **P2109 TP sensor minimum stop range/performance problem**

- The PCM monitors the minimum TP when the closed TP learning is completed. If the TP is **less than 6.03%** or **more than 18.7%**, the PCM determines that there is a TP sensor minimum stop range/performance problem.

### **P2112 Throttle actuator control system range/performance problem**

- The PCM monitors the throttle actuator control duty ratio when the engine is running. If the duty ratio is **more than 95%**, the PCM determines that there is a throttle actuator control system range/performance problem.

### **P2119 Throttle actuator control throttle body range/performance problem**

- The PCM compares the actual TP with initial setting TP when the ignition switch is off. If the difference is less than the specification, the PCM determines that there is a throttle actuator control circuit range/performance problem.

### **P2122 APP sensor No.1 circuit low input**

- The PCM monitors the input voltage from APP sensor No.1 when the engine is running. If the input voltage is **less than 0.35 V**, the PCM determines that the APP sensor No.1 circuit input voltage is low.

## ON-BOARD DIAGNOSTIC [LF]

---

### **P2123 APP sensor No.1 circuit high input**

- The PCM monitors the input voltage from APP sensor No.1 when the engine is running. If the input voltage is **above 4.8 V**, the PCM determines that the APP sensor No.1 circuit input voltage is high.

### **P2127 APP sensor No.2 circuit low input**

- The PCM monitors the input voltage from APP sensor No.2 when the engine is running. If the input voltage is **less than 0.35 V**, the PCM determines that the APP sensor No.2 circuit has a malfunction.

### **P2128 APP sensor No.2 circuit high input**

- The PCM monitors the input voltage from APP sensor No.2 when the engine is running. If the input voltage is **more than 4.8 V**, the PCM determines that the APP sensor No.2 circuit has a malfunction.

### **P2135 TP sensor No.1/No.2 voltage correlation problem**

- The PCM compares the input voltage from TP sensor No.1 with the input voltage from TP sensor No.2 when the engine is running. If the difference is more than the specification, the PCM determines that there is a TP sensor No.1/No.2 voltage correlation problem.

### **P2138 APP sensor No.1/No.2 voltage correlation problem**

- The PCM compares the input voltage from APP sensor No.1 with the input voltage from APP sensor No.2 when the engine is running. If the difference is more than the specification, the PCM determines that there is an APP sensor No.1/No.2 angle correlation problem.

### **P2177 Fuel system too lean at off idle**

- PCM monitors short term fuel trim (SHRTFT), long term fuel trim (LONGFT) during closed loop fuel control at off-idle. If the LONGFT and the sum total of these fuel trims exceed preprogrammed criteria. PCM determines that fuel system is too lean at off-idle.

### **P2178 Fuel system too rich at off idle**

- PCM monitors short term fuel trim (SHRTFT), long term fuel trim (LONGFT) during closed loop fuel control at off-idle. If the LONGFT and the sum total of these fuel trims exceed preprogrammed criteria. PCM determines that fuel system is too rich at off-idle.

### **P2187 Fuel system too lean at idle**

- PCM monitors short term fuel trim (SHRTFT) and long term fuel trim (LONGFT) during closed loop fuel control at idle. If the LONGFT and the sum total of these fuel trims exceed preprogrammed criteria. PCM determines that fuel system is too lean at idle.

### **P2188 Fuel system too rich at idle**

- PCM monitors short term fuel trim (SHRTFT), long term fuel trim (LONGFT) during closed loop fuel control at idle. If the LONGFT and the sum total of these fuel trims exceed preprogrammed criteria. PCM determines that fuel system is too rich at idle.

### **P2195 Front HO2S signal stuck lean**

- The PCM monitors the front HO2S output when the following conditions are met. If the output is **more than 1.15 for 25 s**, the PCM determines that the front HO2S signal remains lean.

#### **MONITORING CONDITION**

- ECT: more than **70 °C {158 °F}**
- Engine speed: **1,000—3,200 rpm**
- MAF amount: **6—80 g/s {0.80—10.58 lb/min}**
- Target A/F feedback system status: feedback control
- Output voltage from the middle HO2S: **more than 0.2 V**

### **P2196 Front HO2S signal stuck rich**

- The PCM monitors the front HO2S output current when the following conditions are met. If the output current is **less than 0.85 for 25 s**, the PCM determines that the front HO2S signal remains rich.

#### **MONITORING CONDITION**

- ECT: **more than 70 °C {158 °F}**
- Engine speed: **1,000—3,200 rpm**
- MAF amount: **6—80 g/s {0.80—10.58 lb/min}**
- Target A/F feedback system status: feedback control
- Output voltage from the middle HO2S: **less than 0.7 V**

### **P2228 BARO sensor circuit low input**

- PCM monitors input voltage from BARO sensor. If input voltage is **below 2.1 V**, PCM determines that BARO sensor circuit has malfunction.

### **P2229 BARO sensor circuit high input**

- PCM monitors input voltage from BARO sensor. If input voltage is **above 4.0 V**, PCM determines that BARO sensor circuit has malfunction.

### **P2401 EVAP system leak detection pump motor circuit low**

- The PCM monitors pump load current (EVAP line pressure), while evaporative leak monitor is operating. If the pump load current is lower than specified, the PCM determines EVAP system leak detection pump motor circuit has a malfunction.

## ON-BOARD DIAGNOSTIC [LF]

### P2402 EVAP system leak detection pump motor circuit high

- The PCM monitors pump load current (EVAP line pressure), while evaporative leak monitor is operating. If the pump load current is higher than specified, the PCM determines EVAP system leak detection pump motor circuit has a malfunction.

### P2404 EVAP system leak detection pump sense circuit problem

- The PCM monitors pump load current (EVAP line pressure), while evaporative leak monitor is operating. After obtaining the reference current value, if the time in which the pump load current reaches the reference current value is less than the specification, the PCM determines air filter has a malfunction.

### P2405 EVAP system leak detection pump sense circuit low input

- The PCM monitors pump load current (EVAP line pressure), while evaporative leak monitor is operating. If the current is lower than the specification while the PCM obtains the reference current value, the PCM determines EVAP system leak detection pump orifice has a malfunction.

### P2407 EVAP system leak detection pump sense circuit intermittent

- The PCM monitors pump load current (EVAP line pressure), while evaporative leak monitor is operating. When either of the following is detected 6 times or more successively, the PCM determines EVAP system leak detection pump heater has a malfunction:
  - While obtaining the reference current value, the change in pump load current exceeds the specification.
  - After obtaining the reference current value, the pump load current is kept lower than the maximum pump load current for more than the specified time.

### P2502 Charging system voltage problem

- PCM judges generator output voltage is **above 17 V** or battery voltage is **below 11 V** during engine running.

### P2503 Charging system voltage low

- PCM needs **more than 20 A** from generator, and judges generator output voltage to be **below 8.5 V** during engine running.

### P2504 Charging system voltage high

- PCM judges generator output voltage is **above 18.5 V** or battery voltage is **above 16.0 V** during engine running.

### P2507 PCM B+ voltage low

- The PCM monitors the voltage of back-up battery positive terminal. If the PCM detects battery positive terminal voltage **below 2.5 V** for **2 s**, the PCM determines that the backup voltage circuit has a malfunction.

### P2610 PCM internal engine off timer performance

- PCM internal engine off timer is damaged.

## KOEO/KOER SELF-TEST[LF]

id010245100400

- The self-test function consists of the KOEO (Key On Engine Off) self-test, performed when the ignition switch is turned to the ON position and the engine is stopped; and the KOER (Key On Engine Running) self-test, performed when idling. If a malfunction is detected when either self-test is executed, a DTC is displayed on the Mazda Modular Diagnostic System (M-MDS). Using the self-test function, the present malfunction or a successful repair is readily confirmed. Refer to the self-test function table for the corresponding DTCs.

### KOEO (Key ON, Engine Off) Self-test

- The KOEO self-test is a powertrain control system self-diagnosis, performed when the ignition switch is turned to the ON position and the engine is stopped. A KOEO self-test begins when the connected Mazda Modular Diagnostic System (M-MDS) sends an execute command to the PCM.
- As the KOEO self-test is performed, the PCM performs the inspection for set DTCs and if a malfunction is detected the DTC is displayed on the Mazda Modular Diagnostic System (M-MDS).

### KOER (Key ON, Engine Running) Self-test

- The KOER self-test is a powertrain control system self-diagnosis, performed when the ignition switch is turned to the ON position and the engine is idling. A KOER self-test begins when the connected Mazda Modular Diagnostic System (M-MDS) sends an execute command to the PCM.
- As the KOER self-test is performed, the PCM performs the inspection for set DTCs and if a malfunction is detected the DTC is displayed on the Mazda Modular Diagnostic System (M-MDS).

# ON-BOARD DIAGNOSTIC [LF]

## KOEO/KOER self-test table

×: Applicable  
N/A: Not applicable

DTC No.		Condition	Test condition	
07MY	06MY		KOEO	KOER
B1342	←	PCM malfunction	×	N/A
P0011	←	CMP timing over-advanced	N/A	×
P0012	←	CMP timing over-retarded	N/A	×
P0016	←	CKP-CMP correlation	N/A	N/A
P0030	←	Front HO2S heater control circuit problem	×	×
P0031	←	Front HO2S heater circuit low input	×	×
P0032	←	Front HO2S heater circuit high input	×	×
P0037	←	Rear HO2S heater circuit low input	×	×
P0038	←	Rear HO2S heater circuit high input	×	×
P0069	←	Manifold absolute pressure/atmospheric pressure correlation	N/A	N/A
P0101	←	MAF sensor circuit range/performance problem	N/A	N/A
P0102	←	MAF sensor circuit low input	×	×
P0103	←	MAF sensor circuit high input	×	×
P0107	←	MAP sensor circuit low input	×	×
P0108	←	MAP sensor circuit high input	×	×
P0111	←	IAT sensor circuit range/performance problem	N/A	N/A
P0112	←	IAT sensor circuit low input	×	×
P0113	←	IAT sensor circuit high input	×	×
P0116	←	Engine coolant temperature circuit range/performance	N/A	N/A
P0117	←	ECT sensor circuit low input	×	×
P0118	←	ECT sensor circuit high input	×	×
P0122	←	TP sensor No.1 circuit low input	×	×
P0123	←	TP sensor No.1 circuit high input	×	×
P0125	←	Excessive time to enter closed loop fuel control	N/A	N/A
P0126	←	Coolant thermostat stuck open	N/A	N/A
P0128	←		N/A	N/A
P0130	←	Front HO2S circuit problem	×	×
P0131	←	Front HO2S circuit low input	×	×
P0132	←	Front HO2S circuit high input	×	×
P0133	←	Front HO2S circuit problem	N/A	N/A
P0134	←	Front HO2S no activity detected	N/A	×
P0137	←	Rear HO2S circuit low input	×	×
P0138	←	Rear HO2S circuit high input	×	×
P0139	←	Rear HO2S circuit problem	N/A	N/A
P0140	←	Rear HO2S no activity detected	N/A	×
P0222	←	TP sensor No.2 circuit low input	×	×
P0223	←	TP sensor No.2 circuit high input	×	×
P0300	←	Random misfire detected	N/A	×
P0301	←	Cylinder No.1 misfire detected	N/A	×
P0302	←	Cylinder No.2 misfire detected	N/A	×
P0303	←	Cylinder No.3 misfire detected	N/A	×
P0304	←	Cylinder No.4 misfire detected	N/A	×
P0327	←	KS circuit low input	×	×
P0328	←	KS circuit high input	×	×
P0335	←	CKP sensor circuit problem	N/A	N/A
P0340	←	CMP sensor circuit problem	N/A	N/A
P0401	←	EGR flow insufficient detected	N/A	×
P0403	←	EGR valve (stepping motor) circuit problem	×	×
P0421	←	Warm up catalyst system efficiency below threshold	N/A	N/A
P0441	←	Evaporative emission control system incorrect purge flow	N/A	×
P0442	←	Evaporative emission control system leak detected (small leak)	N/A	×

## ON-BOARD DIAGNOSTIC [LF]

DTC No.		Condition	Test condition	
07MY	06MY		KOEO	KOER
P0443	←	Purge solenoid valve circuit problem	×	×
P0446	←	Change over valve (COV) (EVAP system leak detection pump) stuck close	N/A	×
P0455	←	Evaporative emission control system leak detected (gross leak)	N/A	×
P0456 <sup>*1</sup>	←	Evaporative emission control system leak detected (very small leak)	N/A	×
P0461	←	Fuel gauge sender unit range/performance problem	N/A	N/A
P0462	←	Fuel gauge sender unit circuit low input	×	×
P0463	←	Fuel gauge sender unit circuit high input	×	×
P0480	←	Cooling fan relay No.1 control circuit malfunction	×	×
P0481	←	Cooling fan relay No.2 control circuit malfunction	×	×
P0482	←	Cooling fan relay No.3 control circuit malfunction	×	×
P0500 <sup>*3</sup>	←	VSS circuit problem	N/A	N/A
P0505	←	Idle speed control system problem	N/A	×
P0506	←	Idle speed control system RPM lower than expected	N/A	N/A
P0507	←	Idle speed control system RPM higher than expected	N/A	×
P050A	N/A	Cold start idle air control system performance	×	×
P050B	N/A	Cold start ignition timing performance	×	×
P0550	←	PSP switch circuit malfunction	N/A	N/A
P0564	←	Cruise control switch circuit malfunction	N/A	N/A
P0571	←	Brake switch circuit problem	N/A	N/A
P0601	←	PCM memory check sum error	×	×
P0602	←	PCM programming error	×	×
P0604	←	PCM random access memory (RAM) error	×	×
P0606	←	PCM processor	×	×
P0610	←	PCM vehicle options error	×	×
P0638	←	Throttle actuator control circuit range/performance problem	N/A	N/A
P0661	←	Variable intake air solenoid valve circuit low input	×	×
P0662	←	Variable intake air solenoid valve circuit high input	×	×
P0703	←	Brake switch input circuit problem	N/A	N/A
P0704 <sup>*2</sup>	←	Clutch pedal position (CPP) switch input circuit problem	N/A	N/A
P0850 <sup>*2</sup>	←	Neutral switch input circuit problem	N/A	N/A
P1260	←	Immobilizer system problem	×	N/A
P2088	←	Oil control valve (OCV) circuit low	×	×
P2089	←	Oil control valve (OCV) circuit high	×	×
P2096	←	Target A/F feedback system too lean	N/A	N/A
P2097	←	Target A/F feedback system too rich	N/A	N/A
P2101	←	Throttle actuator circuit range/performance	N/A	×
P2107	←	Throttle actuator control module processor error	N/A	×
P2108	←	Throttle actuator control module performance error	N/A	×
P2109	←	TP sensor minimum stop range/performance problem	N/A	×
P2112	←	Throttle actuator control system range/performance problem	N/A	×
P2119	←	Throttle actuator control throttle body range/performance problem	N/A	×
P2122	←	APP sensor No.1 circuit low input	×	×
P2123	←	APP sensor No.1 circuit high input	×	×
P2127	←	APP sensor No.2 circuit low input	×	×
P2128	←	APP sensor No.2 circuit high input	×	×
P2135	←	TP sensor No.1/No.2 voltage correlation problem	×	×
P2138	←	APP sensor No.1/No.2 voltage correlation problem	×	×
P2177	←	Fuel system too lean at off idle	N/A	×
P2178	←	Fuel system too rich at off idle	N/A	×
P2187	←	Fuel system too lean at idle	N/A	×
P2188	←	Fuel system too rich at idle	N/A	×

## ON-BOARD DIAGNOSTIC [LF]

DTC No.		Condition	Test condition	
07MY	06MY		KOEO	KOER
P2195	←	Front HO2S signal stuck lean	N/A	N/A
P2196	←	Front HO2S signal stuck rich	N/A	N/A
P2228	←	BARO sensor circuit low input	×	×
P2229	←	BARO sensor circuit high input	×	×
P2401	←	EVAP system leak detection pump motor circuit low	N/A	×
P2402	←	EVAP system leak detection pump motor circuit high	N/A	×
P2404	←	EVAP system leak detection pump sense circuit problem	N/A	×
P2405	←	EVAP system leak detection pump sense circuit low input	N/A	×
P2407	←	EVAP system leak detection pump sense circuit intermittent	N/A	×
P2502	←	Charging system voltage problem	N/A	×
P2503	←	Charging system voltage low	N/A	×
P2504	←	Charging system voltage high	N/A	×
P2507	←	PCM B+ voltage low	×	×
P2610	←	PCM internal engine off timer performance	N/A	N/A

\*1 : California emission regulation applicable model

\*2 : MT

\*3 : With ABS/DSC or MT without ABS/DSC

### PID/DATA MONITOR AND RECORD[LF]

id010245100500

- The PID/DATA monitor items are shown below.

#### PID/DATA monitor table (reference)

×: Applicable  
N/A: Not applicable

Item		definition	Unit/Condition		PCM terminal
07MY	06MY				
AAT	←	Ambient air temperature	°C	°F	N/A
AC_REQ	←	Refrigerant pressure switch (high, low)	Off/On		1AU
ACCS	←	A/C relay	Off/On		1I
AFR	←	Air/fuel ratio	N/A		2AD
AFR_ACT	←	Actual air/fuel ratio	N/A		N/A
ALTF	←	Generator field coil control duty value	%		2AI
ALTT V	←	Generator output voltage	V		2AJ
APP	←	Accelerator pedal position	%		1AO, 1AP
APP1	←	APP sensor No.1	%		1AO
	←		V		
APP2	←	APP sensor No.2	%		1AP
	←		V		
ARPMDES	←	Target engine speed	RPM		N/A
BARO	←	Barometric pressure	Pa		N/A
	←		V		
BOO	←	Brake switch	Off/On		1AB, 1AF
BPA	N/A	Brake pressure applied switch	Off/On		N/A
CATT11_DSD	←	Catalyst temperature	°C	°F	N/A
CHRGLP	←	Generator warning light	Off/On		N/A
COLP	←	Refrigerant pressure switch (middle)	OFF/ON		1J
CPP*1	←	Clutch pedal position	Off/On		1D
CPP/PNP*1	←	Shift lever position	Drive/Neutral		1X
DTCCNT	←	Number of DTC detected	N/A		N/A
ECT	←	Engine coolant temperature	°C	°F	2AH
	←		V		
EQ_RAT11	←	Actual lambda signal	N/A		N/A

## ON-BOARD DIAGNOSTIC [LF]

Item		definition	Unit/Condition	PCM terminal
07MY	06MY			
EQ_RAT11_DSD	←	Target lambda	N/A	N/A
ETC_ACT	←	Throttle control	°	N/A
ETC_DSD	←	Throttle control desired	%	N/A
	←		°	
EVAPCP	←	Purge solenoid valve duty value	%	2C
FAN1	←	Cooling fan relay No.1 control signal	Off/On	1M
FAN2	←	Cooling fan relay No.2 control signal	Off/On	1N
FAN3	←	Cooling fan relay No.3 control signal	Off/On	1R
FLI	←	Fuel level	%	N/A
FP	←	Fuel pump relay	Off/On	1H
FUELPW	←	Fuel injector duration	sec	2BB, 2BC, 2BD, 2AZ
FUELSYS	←	Fuel system status	OL/CL/ OL-Drive/ OL-Fault/ CL-Fault	N/A
GENVDSD	←	Target generator voltage	V	N/A
HTR11	←	Front HO2S heater control	Off/On	2BG
HTR12	←	Rear HO2S heater control	Off/On	2BE
IAT	←	Intake air temperature	°C   °F	1AT
	←		V	
IMTV	←	Variable intake air control	Off/On	2J
INGEAR	←	Gears are engaged	Off/On	1D,1X
	←			N/A
IVS	←	CTP condition	Idle/Off Idle	N/A
KNOCKR	←	Knocking retard	°	2U
LDP_EVAPCP	←	EVAP system leak detection pump detect incorrect purge flow	A	N/A
LDP_IDL	←	EVAP system leak detection pump idle current	A	N/A
LDP_MON	←	EVAP system leak detection pump monitoring current	A	N/A
LDP_REF	←	EVAP system leak detection pump reference current	A	N/A
LDP_SLDV	←	EVAP system small leak detection value	A	N/A
LDP_VSL_FV	←	EVAP system very small leak detection fail value	mA/sec	N/A
LDP_VSL_SV	←	EVAP system very small leak detection safe value	mA/sec	N/A
LDP_VSLDV <sup>*2</sup>	←	EVAP system very small leak detection value	mA/sec	N/A
LOAD	←	Engine load	%	N/A
LONGFT1	←	Long term fuel trim	%	N/A
MAF	←	Mass air flow	g/sec	1AK
	←		V	
MAP	←	Manifold absolute pressure	Pa	2AG
	←		V	
MIL	←	Malfunction indicator lamp	Off/On	N/A
MIL_DIS	←	Travelled distance since MIL illuminated	km	N/A
O2S11	←	Front HO2S	A	2AD
O2S12	←	Rear HO2S	V	2Q
PSP	←	PSP switch	Low/High	2T
RFCFLAG	←	PCM adaptive memory produce verification	Not Learnt/ Learnt	N/A
RO2FT1	←	Rear HO2S fuel trim	N/A	N/A
RPM	←	Engine speed	RPM	2W
SCCS	←	Cruise control switch	V	1AQ
SEGRP	←	EGR control	N/A	2K, 2G, 2L, 2H
SEGRP DSD	←	EGR valve position desired	%	N/A

## ON-BOARD DIAGNOSTIC [LF]

Item		definition	Unit/Condition	PCM terminal
07MY	06MY			
SELTESTDTC	N/A	Diagnostic trouble codes	N/A	N/A
SHRTFT1	←	Short term fuel trim (front)	%	N/A
SHRTFT12	←	Short term fuel trim (rear)	%	N/A
SPARKADV	←	Ignition timing	°	2S
test	←	Test mode	Off/On	N/A
TIRESIZE	←	Tire revolution per mile	rev/mile	N/A
TP REL	←	Throttle position signal (relative value)	%	N/A
TP1	←	TP sensor No.1	%	2AK
	←		V	
TP2	←	TP sensor No.2	%	2AL
	←		V	
TPCT	←	TP sensor voltage at CTP	V	N/A
VPWR	←	Battery positive voltage	V	1BA
VSS	←	Vehicle speed	KPH	2O <sup>*4</sup>
	←			1AM <sup>*3, 5</sup> , 1AI <sup>*3, 5</sup>
VT ACT1	←	Actual valve timing	°	2E
VT DIFF1	←	Difference between target valve timing and actual valve timing	°	N/A
VT DUTY1	←	OCV control)	%	2E

\*1 : MT

\*2 : California emission regulation applicable model

\*3 : With ABS, DSC HU/CM

\*4 : MT without ABS/DSC

\*5 : AT without ABS/DSC

# ON-BOARD DIAGNOSTIC [LF]

## SIMULATION TEST[LF]

id010245100600

- The simulation items are shown below.

### Simulation item table

×: Applicable  
N/A: Not applicable

Item		Applicable component	Unit/condition	Test condition		PCM terminal
07MY	06MY			KOEO	KOER	
ACCS	←	A/C relay	Off/On	×	×	1I
ALTF	←	Generator (field coil)	%	N/A	×	2AI
ARPMDES	N/A	Target engine speed	RPM	×	×	N/A
EVAPCP	←	Purge solenoid valve	%	×	×	2C
FAN1	←	Cooling fan relay No.1	Off/On	×	×	1M
FAN2	←	Cooling fan relay No.2	Off/On	×	×	1N
FAN3	←	Cooling fan relay No.3	Off/On	×	×	1R
FP	←	Fuel pump relay	Off/On	×	×	1H
FUELPW1	←	Fuel injector	%	×	×	2BB, 2BC, 2BD, 2AZ
GENVDSD	←	Target generator voltage	V	N/A	×	N/A
HTR11	←	Front HO2S heater	Off/On	×	×	2BG
HTR12	←	Rear HO2S heater	Off/On	×	×	2BE
IMTV	←	Variable intake air solenoid valve	Off/On	×	×	2J
INJ_1	←	Fuel injector No.1	OFF	N/A	×	2BB
INJ_2	←	Fuel injector No.2	OFF	N/A	×	2BC
INJ_3	←	Fuel injector No.3	OFF	N/A	×	2BD
INJ_4	←	Fuel injector No.4	OFF	N/A	×	2AZ
SEGRP	←	EGR valve stepping motor position	N/A	×	×	2K, 2G, 2L, 2H
test	←	Test mode	Off/On	×	×	N/A
VT DUTY1 Wt	←	CMP sensor	%	×	×	2E



# 01-40 CONTROL SYSTEM [LF]

## FUEL INJECTION CONTROL

OPERATION[LF] ..... 01-40-1  
 Operation ..... 01-40-1  
 Injection Time ..... 01-40-1

Determination of Effective  
 Injection Time ..... 01-40-2  
 Fuel Cut ..... 01-40-4

## FUEL INJECTION CONTROL OPERATION[LF]

id014045101900

### Operation

#### Injection timing

- There is synchronized fuel injection, which performs fuel injection by the setting of the crankshaft position, and non-synchronized fuel injection which performs fuel injection when the condition for fuel injection is met regardless of the crankshaft position.

#### Synchronized fuel injection

- The crankshaft rotation is synchronized by each intake and exhaust stroke of the cylinders, and fuel injection is performed by the fuel injection timing and the injection amount corresponding to the input signals of the following sensors.
  - CKP sensor, MAF sensor, ECT sensor, IAT sensor

#### Non-synchronized fuel injection

- The crankshaft rotation is not synchronized and fuel injection is performed by the injection timing and injection amount as triggered by the input signals of the following sensors.
  - TP sensor, MAF sensor, ECT sensor, IAT sensor

#### Relation between synchronized and non-synchronized fuel injection

- If synchronized and non-synchronized fuel injection happen to occur together, fuel is injected by adding the fuel injection timing of both.

### Injection Time

- The PCM calculates the fuel injection amount according to the engine operation conditions as the fuel injection time and energizes the fuel injectors.

#### Fuel injector energization time and operation conditions

- The fuel injectors cause an operation delay with the start of energization from the PCM. The PCM calculates the fuel injection time by adding the non-injection time (ineffective injection time) with the actual injection time (effective injection time), and energizes the fuel injectors for this time.
- The fuel injection time is based on the following formula:

$$\text{Fuel injection time} = \text{effective injection time} + \text{ineffective injection time}$$

- The fuel injectors cause a delay in operation due to a delay in the build-up of operation current from coil inductance with the start of energization, and by the mass of the needle valve and plunger, and spring resistance. This delay is the ineffective injection time.
- The non-injection time is affected by the change in battery voltage. Accordingly, the PCM sets the non-injection time according to the battery voltage

#### Effective injection time

- The fuel injector opening valve time which is the actual fuel injection time is called the effective injection amount.

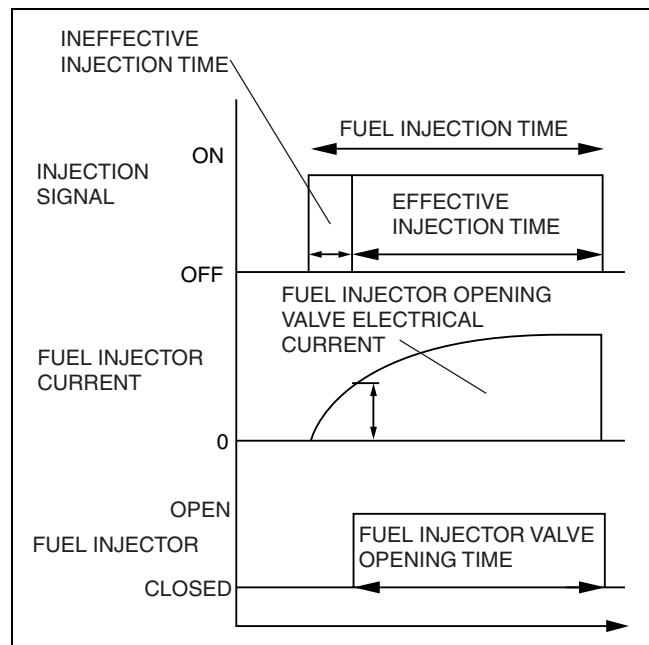

amxuun000003

Mazda MX-5

# CONTROL SYSTEM [LF]

## Determination of Effective Injection Time

- The PCM divides the engine operation conditions into control zones according to engine speed and engine load and determines the effective injection time at each control zone to perform optimum air/fuel ratio control in all engine driving ranges.

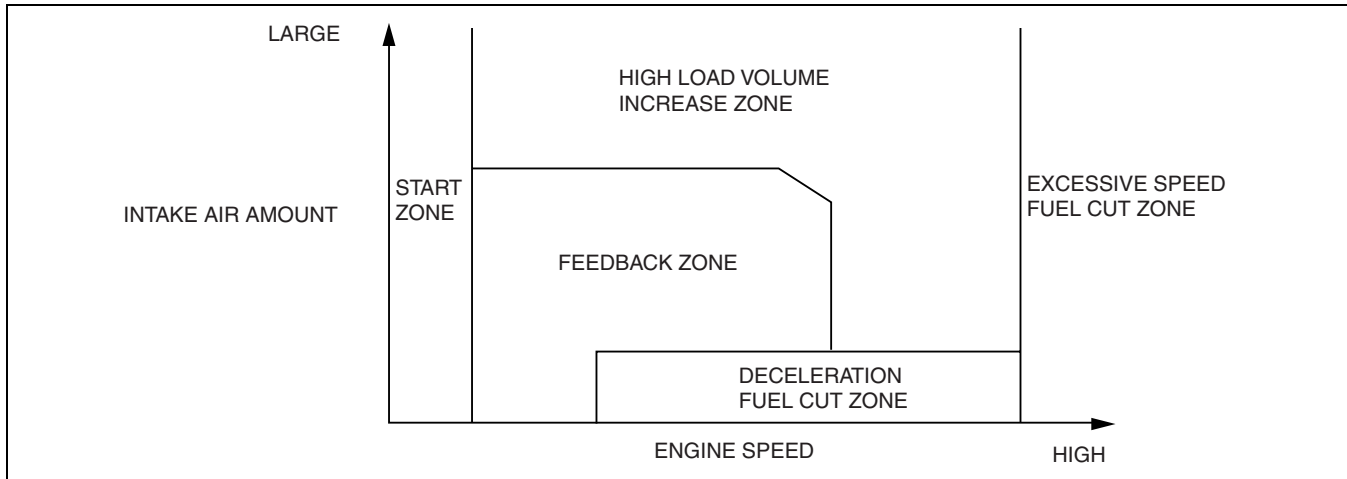

amxuun000003

### Start zone

#### Purpose

- Improved engine startability

#### Operation condition

- When engine speed is 500 rpm or less.

#### Determination of fuel injection time

- According to engine coolant temperature (ECT sensor) and engine speed (CKP sensor)

### Feedback Zone

#### Purpose

- Improved fuel economy
- Improved exhaust gas purification

#### Control condition

- During engine operation other than high load volume increase zone and engine start zone.

#### Determination of fuel injection time

- During normal driving, the amounts of various correction types are added to the basic injection time to set to the theoretical air/fuel ratio.

### High load volume increase zone

#### Purpose

- Improved driveability
- TWC protection

#### Control condition

- Either the charging efficiency or the throttle valve opening angle is a fixed value or more.

#### Determination of fuel injection time

- Corrections are added to the basic injection amount and the high load coefficient is calculated according to the engine speed, mass intake airflow amount and the throttle valve opening angle.

### Excessive speed fuel cut zone

#### Purpose

- Engine protection

#### Control conditions

- When the engine speed is 7,000 rpm or more (WOT).
- When engine speed is 5,500 rpm or more and the engine coolant temperature is approx.  $-15\text{ }^{\circ}\text{C}$  { $5\text{ }^{\circ}\text{F}$ } or less.
- When the following conditions continue for 5 min or more:
  - Vehicle is stopped.
  - Engine speed is 1,500 rpm or more.
  - Engine coolant temperature is approx.  $40\text{ }^{\circ}\text{C}$  { $104\text{ }^{\circ}\text{F}$ }.
- When the following conditions continue for 2 min or more:
  - Vehicle is stopped.
  - Engine speed is 3,000 rpm or more.
  - Engine coolant temperature is approx.  $40\text{ }^{\circ}\text{C}$  { $104\text{ }^{\circ}\text{F}$ }.

## CONTROL SYSTEM [LF]

- When the following conditions continue for 10 s or more:
  - Vehicle is stopped.
  - Engine speed is 6,500 rpm or more.
  - Engine coolant temperature is approx. 40 °C {104 °F}.

**Note**

- The PCM determines that the driver continues to unintentionally depress the accelerator pedal

**Determination of fuel injection time**

- Fuel injection time is set to 0 (fuel cut).

**Deceleration fuel cut zone**

**Purpose**

- Improved fuel economy
- Prevents overheating of the catalytic converter

**Control conditions**

- When the engine conditions are as follows (10 s or longer after engine start):
  - Fully closed throttle valve
  - When the engine speed is at set value or more (differs depending on the ECT) (charging efficiency at fixed value or more, mass airflow sensor normal)

**Determination of fuel injection time**

- The fuel injection time is set to 0 (fuel cut).

**Calculation method list for fuel injection time**

A: Fuel injection time base, B: Correction for fuel injection time

Contents (Fuel injection time, calculation method, or determination method)		Control zone				
		Start	Feedback	High load volume increase	Excessive speed fuel cut	Deceleration fuel cut
Injection time at start	Set value according to engine coolant temperature (low engine coolant temperature→long injection time)	A				
Basic injection time	Basic injection time = charging efficiency x fuel flow coefficient		A	A		
Fuel cut	Fuel injection time = 0				A	A
Ineffective injection time	Set time according to injector performance	A	A	A		
Volume increase correction at engine start	Purpose: Maintains stability of engine speed just after engine start <b>Correction condition</b> <ul style="list-style-type: none"> <li>• Specified time according to engine coolant temperature directly after engine start</li> </ul> <b>Correction amount</b> <ul style="list-style-type: none"> <li>• Low engine coolant temperature→large correction</li> <li>• Low intake air temperature→large correction</li> </ul>	B	B			
Front HO2S feedback correction	Purpose: Controls air/fuel ratio to the theoretical air/fuel ratio <b>Correction condition</b> <ul style="list-style-type: none"> <li>• When engine coolant temperature is at set value or more</li> </ul> <b>Correction amount</b> <ul style="list-style-type: none"> <li>• Front HO2S current value 0 mA or less→volume decrease correction</li> <li>• Front HO2S current value 0 mA or more→volume increase correction</li> </ul>		B			
Rear HO2S feedback correction	Purpose: Corrects feedback amount according to deterioration of front HO2S and catalytic converter <b>Correction condition</b> <ul style="list-style-type: none"> <li>• Engine coolant temperature is at set value or more</li> <li>• Engine speed is 500—4,250 rpm</li> <li>• Charging efficiency is 10—80%</li> </ul> <b>Correction amount</b> <ul style="list-style-type: none"> <li>• According to rear HO2S electromotive force→correction</li> </ul>		B			

## CONTROL SYSTEM [LF]

D-range correction (AT)	<p>Purpose: Ensures engine speed stability during D-range shifting</p> <p><b>Correction condition</b></p> <ul style="list-style-type: none"> <li>Throttle valve fully-closed and shifted into D range</li> </ul> <p><b>Correction amount</b></p> <ul style="list-style-type: none"> <li>Low engine coolant temperature→large correction</li> </ul>		B			
High load volume increase correction	<p>Purpose: Improved engine output, decrease of exhaust gas temperature</p> <p><b>Correction condition</b></p> <ul style="list-style-type: none"> <li>According to engine speed when the throttle valve opening angle is the fixed value or more, otherwise, according to engine speed and charging efficiency</li> </ul> <p><b>Correction amount</b></p> <ul style="list-style-type: none"> <li>High engine speed, high charging efficiency→large correction</li> </ul>			B		
Warm-up volume increase correction	<p>Purpose: When engine coolant temperature is low, maintains combustion stability</p> <p><b>Correction condition</b></p> <ul style="list-style-type: none"> <li>While at set engine coolant temperature</li> </ul> <p><b>Correction amount</b></p> <ul style="list-style-type: none"> <li>High charging efficiency, low engine coolant temperature→large correction</li> </ul>		B	B		
A/C load increase correction	<p>Purpose: Maintains engine speed stability during A/C operation</p> <p><b>Correction condition</b></p> <ul style="list-style-type: none"> <li>A/C is operating</li> </ul> <p><b>Correction amount</b></p> <ul style="list-style-type: none"> <li>Low engine coolant temperature→large correction</li> </ul>		B	B		
Acceleration increase correction	<p>Purpose: Corrects fuel injection delay during acceleration to ensure drive stability</p> <p><b>Correction condition</b></p> <ul style="list-style-type: none"> <li>When acceleration amount (change in the amount of charging efficiency) is at set value or more</li> </ul> <p><b>Correction amount</b></p> <ul style="list-style-type: none"> <li>Low engine coolant temperature→large correction</li> <li>Large acceleration amount→large correction</li> </ul>		B	B		
Deceleration volume increase correction	<p>Purpose: Ensures engine speed stability after fuel cut recovery</p> <p><b>Correction condition</b></p> <ul style="list-style-type: none"> <li>When recovery from fuel cut</li> </ul> <p><b>Correction amount</b></p> <ul style="list-style-type: none"> <li>Low engine speed→large correction</li> </ul>		B			
Learning correction	<p>Purpose: Corrects deviation in air/fuel ratio from changes due to aged deterioration of mechanical devices</p> <p><b>Correction condition</b></p> <ul style="list-style-type: none"> <li>Under any condition except purge control</li> </ul> <p><b>Correction amount</b></p> <ul style="list-style-type: none"> <li>Learning value based on average of feedback correction value</li> </ul>		B	B		
Intake air pressure correction	<p>Purpose: Corrects ineffective charging time deviation from change in intake manifold vacuum</p> <p><b>Correction condition</b></p> <ul style="list-style-type: none"> <li>Under any condition except start zone</li> </ul> <p><b>Correction amount</b></p> <ul style="list-style-type: none"> <li>More intake manifold vacuum→large correction</li> </ul>		B	B		

### Fuel Cut

- Includes fuel cut under the following conditions except fuel cut at excessive engine speed according to engine operation and deceleration fuel cut.

### Sensor damage fuel cut

#### Purpose

- To prevent engine damage from abnormal ignition due to a malfunction input of a cylinder identification or the engine speed signal.

#### Control condition

- When damage to the crankshaft position sensor or camshaft position sensor is detected.

### **Dechoke control**

#### **Purpose**

- To improve engine starting startability when spark plugs are flooded.

#### **Control conditions**

- When cranking close to fully-open throttle valve

### **Fuel cut during immobilizer system activation**

#### **Purpose**

- To prevent vehicle theft

#### **Execution conditions**

- When an engine stop request signal is received from the immobilizer system, the PCM force-stops the fuel injectors. Therefore the engine stops.



# BODY & ACCESSORIES

**09**  
SECTION

<b>GLASS/WINDOWS/ MIRRORS</b> . . . . .	<b>09-12</b>	<b>EXTERIOR TRIM</b> . . . . .	<b>09-16</b>
<b>SECURITY AND LOCKS [ADVANCED KEYLESS SYSTEM]</b> . . . . .	<b>09-14</b>	<b>INSTRUMENTATION/ DRIVER INFO.</b> . . . . .	<b>09-22</b>
		<b>CONTROL SYSTEM</b> . . . . .	<b>09-40</b>

## 09-12 GLASS/WINDOWS/MIRRORS

<b>POWER WINDOW SYSTEM OUTLINE.</b> . . . . .	<b>09-12-1</b>	<b>EXTERIOR OPEN FUNCTION BLOCK DIAGRAM.</b> . . . . .	<b>09-12-4</b>
<b>POWER WINDOW SYSTEM WIRING DIAGRAM.</b> . . . . .	<b>09-12-2</b>	<b>EXTERIOR OPEN FUNCTION OPERATION</b> . . . . .	<b>09-12-5</b>
<b>EXTERIOR OPEN FUNCTION OUTLINE</b> . . . . .	<b>09-12-3</b>	Open Function/Operation in Conjunction with Transmitter . . . . .	<b>09-12-5</b>
<b>EXTERIOR OPEN FUNCTION STRUCTURAL VIEW</b> . . . . .	<b>09-12-4</b>	Operation Prohibition/ Stop Condition . . . . .	<b>09-12-5</b>

### POWER WINDOW SYSTEM OUTLINE

id091200100100

- An exterior open function has been added to the power window system.
- The power retractable hardtop and power windows operate simultaneously such that the power windows open at the same time the power retractable hardtop begins to operate.

# GLASS/WINDOWS/MIRRORS

## POWER WINDOW SYSTEM WIRING DIAGRAM

id091200100300

With exterior open function

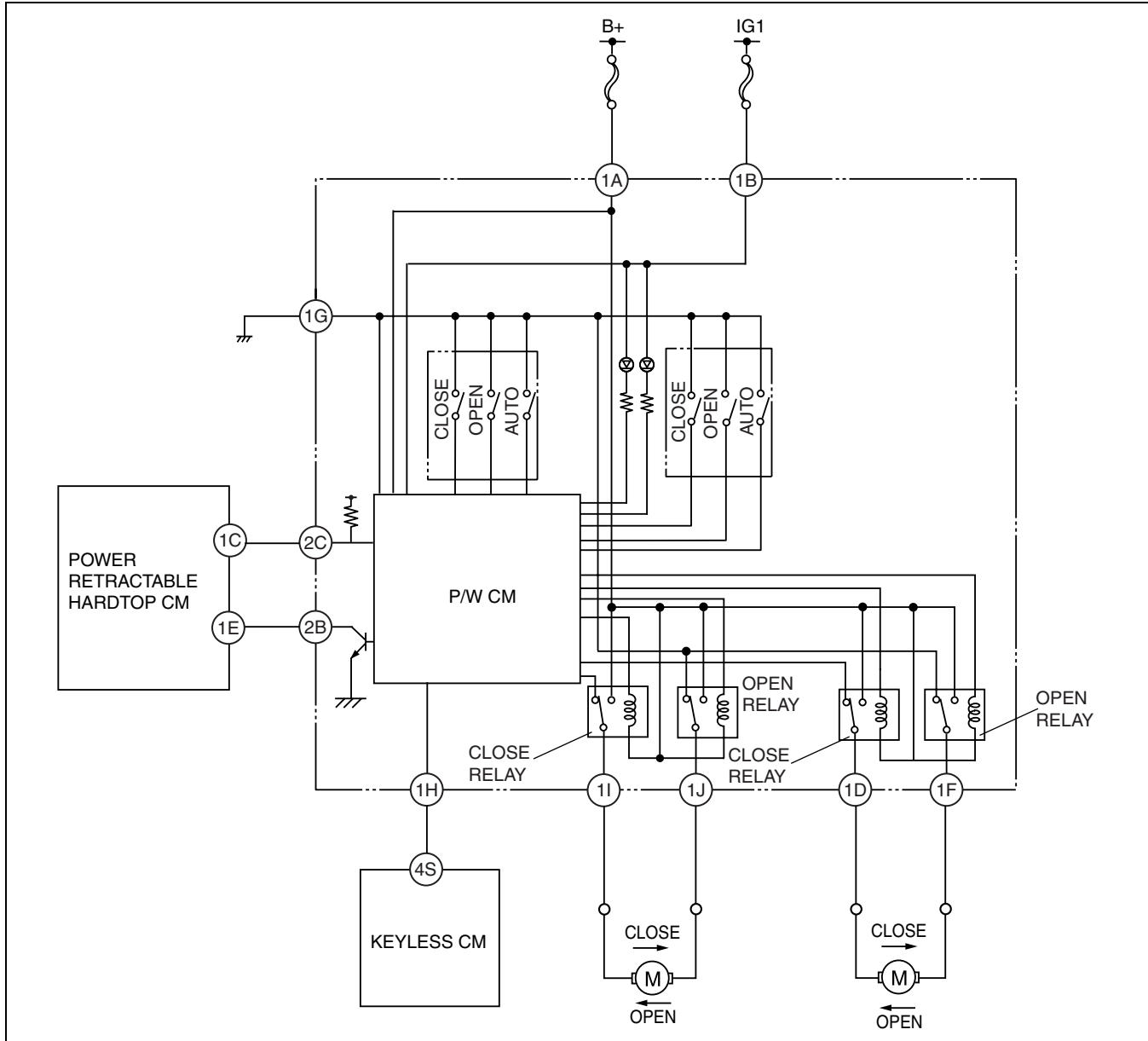

amxuuw000007

# GLASS/WINDOWS/MIRRORS

## Without exterior open function

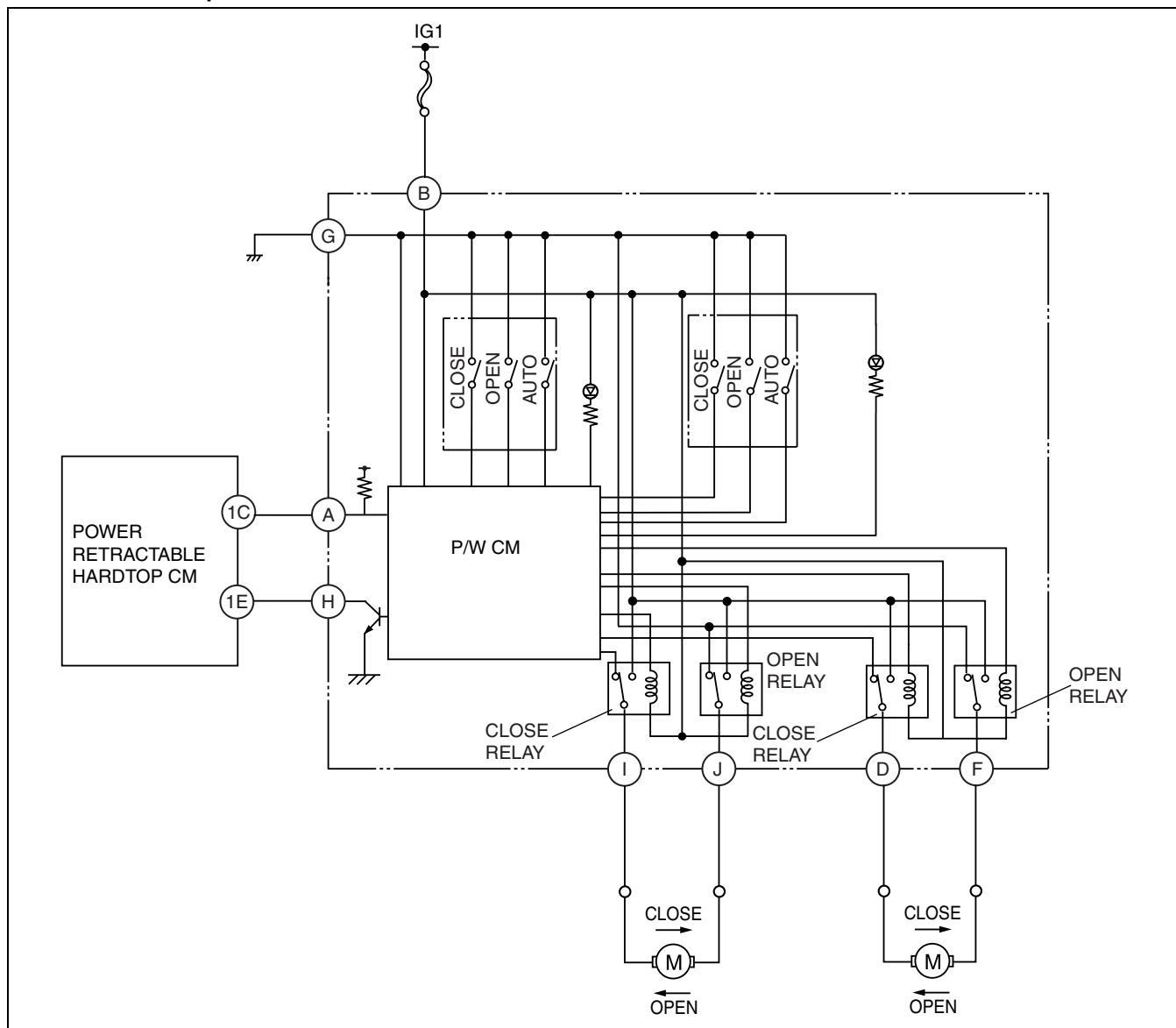

amxuuw000007

Mazda MX-5

## EXTERIOR OPEN FUNCTION OUTLINE

id091200103000

- An exterior open function has been adopted so that the power window system can be operated from outside the vehicle.
- This system can operate in conjunction with the transmitter (open operation only).

Operation item	Open operation (Automatic open)
Transmitter	UNLOCK button operation (long press, approx. 1.5 s or more)

# GLASS/WINDOWS/MIRRORS

## EXTERIOR OPEN FUNCTION STRUCTURAL VIEW

id091200103100

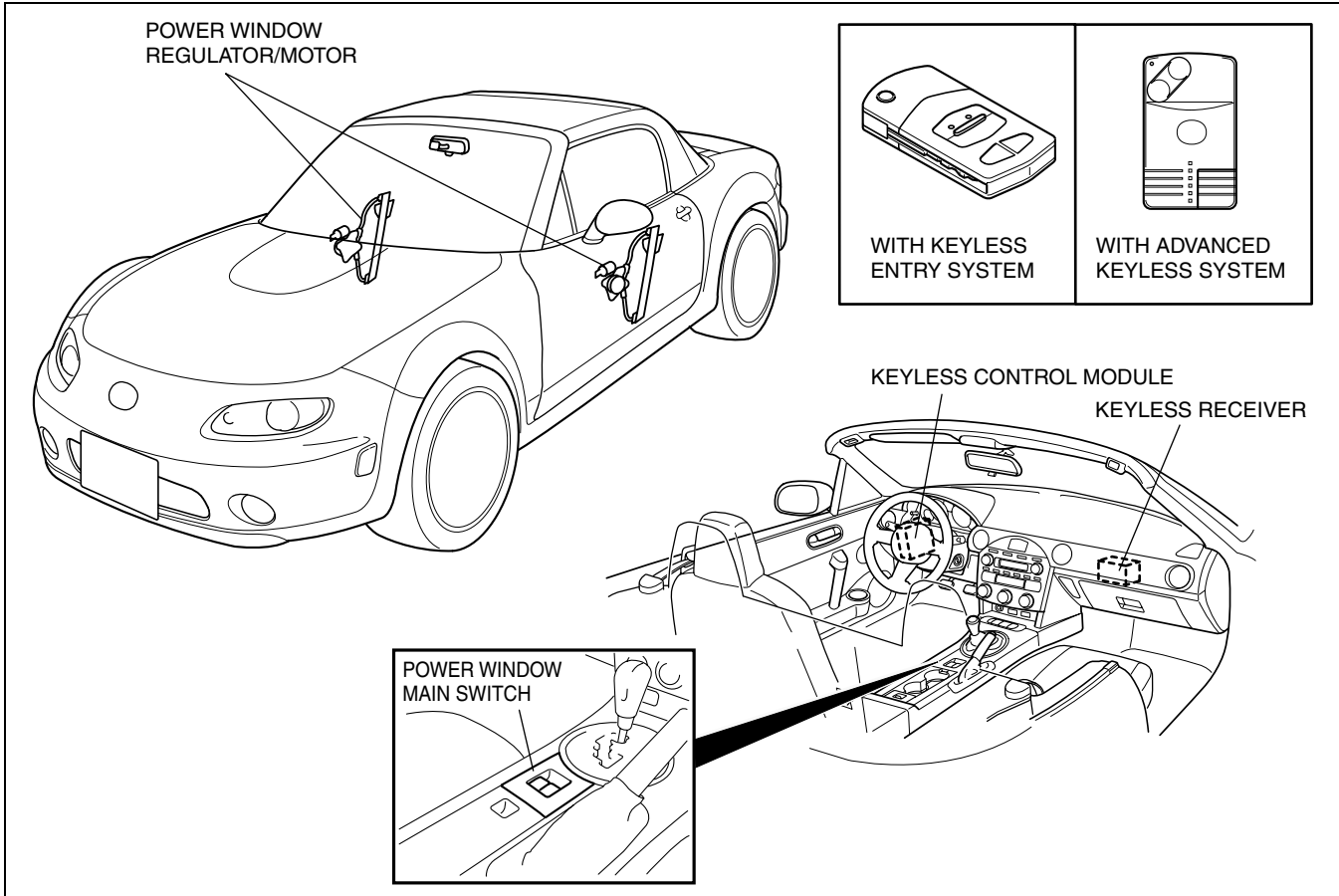

amxuun000000

## EXTERIOR OPEN FUNCTION BLOCK DIAGRAM

id091200103200

### With Advanced Keyless System

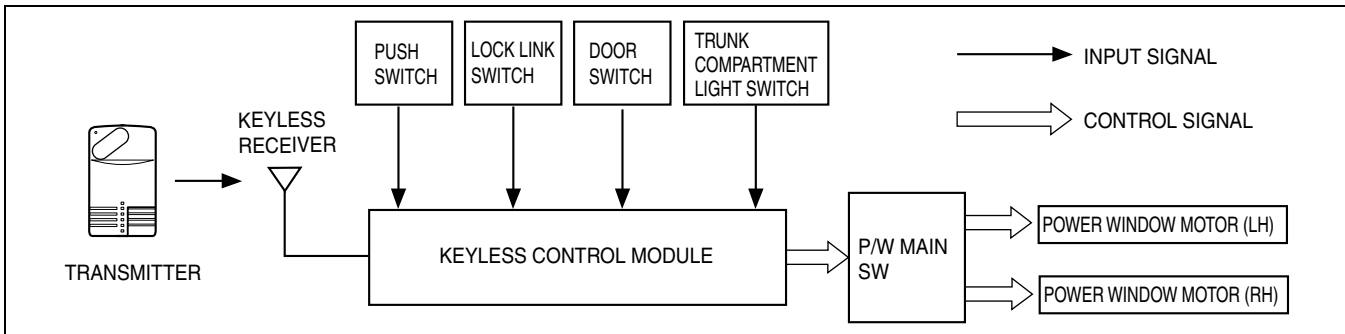

amxuun000000

### With Keyless Entry System

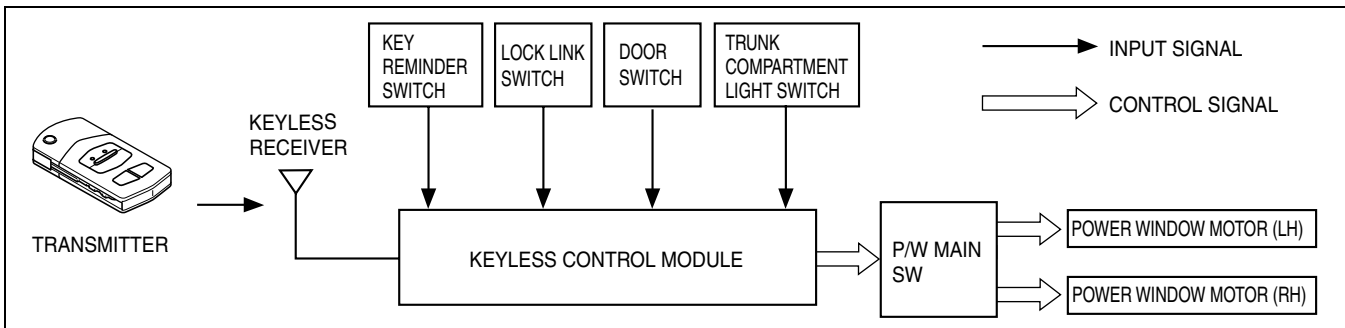

amxuun000000

# GLASS/WINDOWS/MIRRORS

id091200103300

## EXTERIOR OPEN FUNCTION OPERATION

- With the system, door glass can open in conjunction with the UNLOCK operation of the transmitter.
- One opening operation fully opens (automatic open) door glass.
- The keyless control module sends the signal requiring the open operation to the power window control unit (power window main switch) based on the signals input from the switches.
- The power window control unit (power window main switch) sends open operation signal to the power window motor based on the required signal, and operates the door glass.

### Open Function/Operation in Conjunction with Transmitter

- The door glass can be opened by holding the button in the UNLOCK position for **approx. 1.5 s or more** within the transmitter reception area.
- When the door glass is not fully open, operate and hold the transmitter UNLOCK position for **approx. 1.5 s**, and the door glass performs automatic open operation to fully open the door glass. During the automatic open operation, if the transmitter is operated again<sup>\*1</sup>, it stops in that position.

\*1 : The operation button can be either the LOCK/UNLOCK/PANIC button. Also, the holding time is not factored.

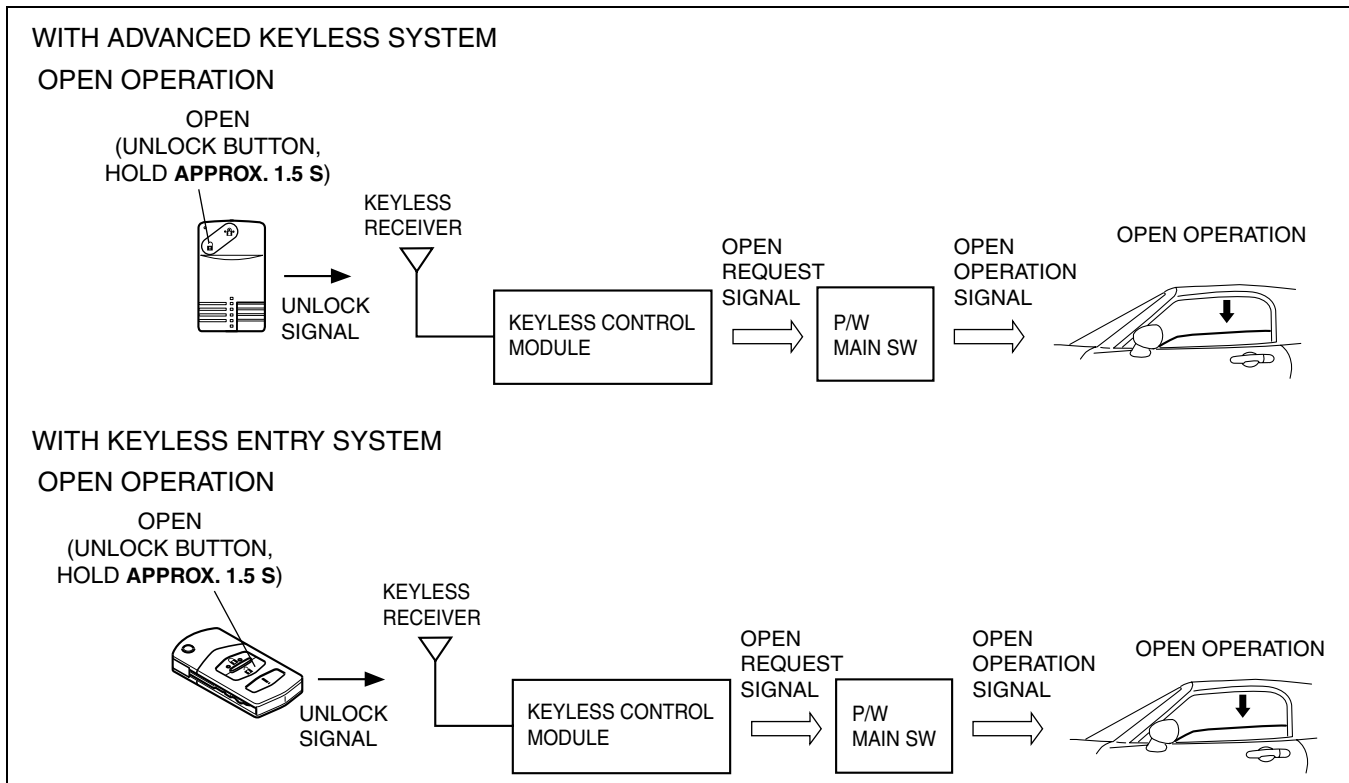

amxuun000000

### Operation Prohibition/Stop Condition

- When the following conditions are met before the operation, the exterior open function does not operate. Also, if the conditions are met during the operation, the operation stops.
  - Either door/trunk is open (when the door switch or trunk compartment light switch is ON)
  - The key is inserted in the steering lock (when the keyless switch is ON)
  - The push switch is pressed in or the start knob (ignition switch) is in a position other than the LOCK (with advanced keyless system)
  - The transmitter is not in the reception area
  - The transmitter is operated during the operation (LOCK, UNLOCK, PANIC operation)



# 09-14 SECURITY AND LOCKS [ADVANCED KEYLESS SYSTEM]

**SECURITY AND LOCKS OUTLINE  
[ADVANCED  
KEYLESS SYSTEM] . . . . . 09-14-1**

**ON-BOARD DIAGNOSYS SYSTEM  
OPERATION[ADVANCED KEYLESS  
SYSTEM] . . . . .09-14-1**

**SECURITY AND LOCKS OUTLINE[ADVANCED KEYLESS SYSTEM]**

id0914b1100100

- Due to the adoption of the power retractable hardtop, DTC U0207 has been added.

**ON-BOARD DIAGNOSYS SYSTEM OPERATION[ADVANCED KEYLESS SYSTEM]**

id0914b1111000

**DTC Table**

DTC	System malfunction location
U0207	Abnormal message from power retractable hardtop control module

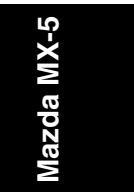



# 09-16 EXTERIOR TRIM

EXTERIOR TRIM OUTLINE .....	09-16-1	Construction .....	09-16-13
EXTERIOR TRIM		Operation .....	09-16-14
STRUCTURAL VIEW .....	09-16-1	<b>DECK PANEL LINK</b>	
POWER RETRACTABLE HARDTOP		<b>CONSTRUCTION/OPERATION</b> .....	09-16-15
SYSTEM OUTLINE .....	09-16-1	Construction .....	09-16-15
POWER RETRACTABLE HARDTOP		Operation .....	09-16-15
SYSTEM STRUCTURAL VIEW.....	09-16-2	<b>ROOF/DECK PANEL MOTOR</b>	
POWER RETRACTABLE HARDTOP		<b>FUNCTION</b> .....	09-16-16
SYSTEM WIRING DIAGRAM .....	09-16-3	<b>ROOF/DECK PANEL MOTOR</b>	
POWER RETRACTABLE HARDTOP		<b>CONSTRUCTION</b> .....	09-16-17
SYSTEM OPERATION .....	09-16-4	<b>POWER RETRACTABLE HARDTOP</b>	
Operation Conditions .....	09-16-4	<b>SWITCH OUTLINE</b> .....	09-16-18
Power Retractable Hardtop		<b>POWER RETRACTABLE</b>	
Operation .....	09-16-4	<b>HARDTOP SWITCH</b>	
<b>POWER RETRACTABLE HARDTOP</b>		<b>CONSTRUCTION/OPERATION</b> .....	09-16-18
<b>CONTROL MODULE FUNCTION</b> .....	09-16-10	<b>ON-BOARD DIAGNOSTIC OUTLINE</b> .....	09-16-19
<b>FAIL-SAFE FUNCTION</b> .....	09-16-11	Special Features .....	09-16-19
Buzzer operation function .....	09-16-12	<b>ON-BOARD DIAGNOSTIC PID DATE</b>	
Power retractable hardtop indicator light		<b>MONITOR FUNCTION</b> .....	09-16-19
control .....	09-16-12	On-board Diagnostic Function .....	09-16-19
<b>POWER RETRACTABLE HARDTOP LINK</b>		PID/Data Monitor Function .....	09-16-21
<b>CONSTRUCTION/OPERATION</b> .....	09-16-13		

## EXTERIOR TRIM OUTLINE

id091600100100

- Convertible top has been adopted.
- A power retractable hardtop system has been adopted which opens/closes automatically via switch operation.

## EXTERIOR TRIM STRUCTURAL VIEW

id091600100200

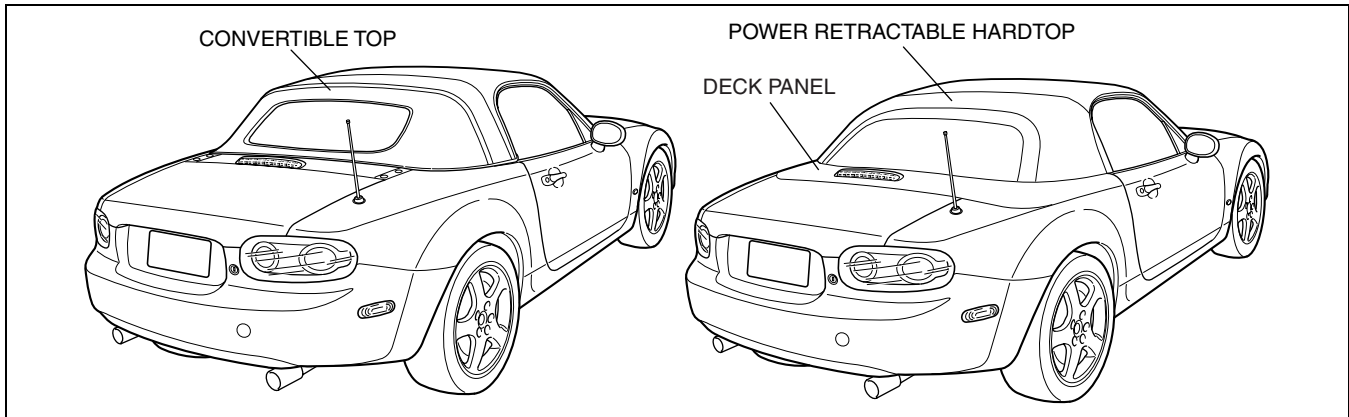

amxuun0000003

## POWER RETRACTABLE HARDTOP SYSTEM OUTLINE

id091600101000

- A switch-operated, open/close power retractable hardtop system has been adopted.
- The power retractable hardtop system consists of the following functions:
  - Auto-open/close function
  - Fail-safe function
  - Malfunction detection function
- The buzzer sounds during operation and when a malfunction is detected.
- Since the power retractable hardtop operates in conjunction with the power windows, the door glass opens **100 mm** at the same time the power retractable hardtop begins to operate.

Mazda MX-5

# EXTERIOR TRIM

## POWER RETRACTABLE HARDTOP SYSTEM STRUCTURAL VIEW

id091600101100

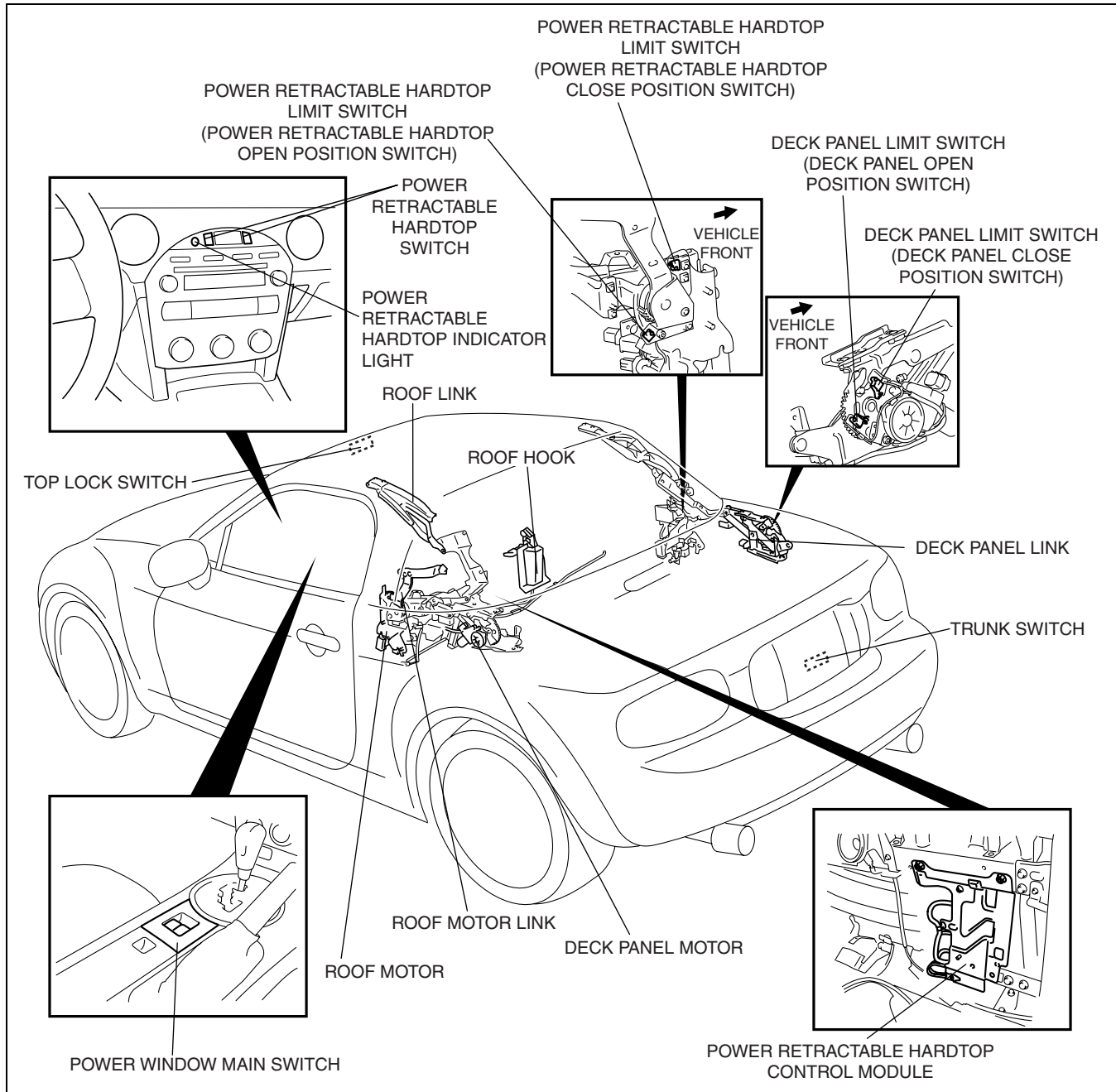

amxuun000005

# EXTERIOR TRIM

## POWER RETRACTABLE HARDTOP SYSTEM WIRING DIAGRAM

id091600101200

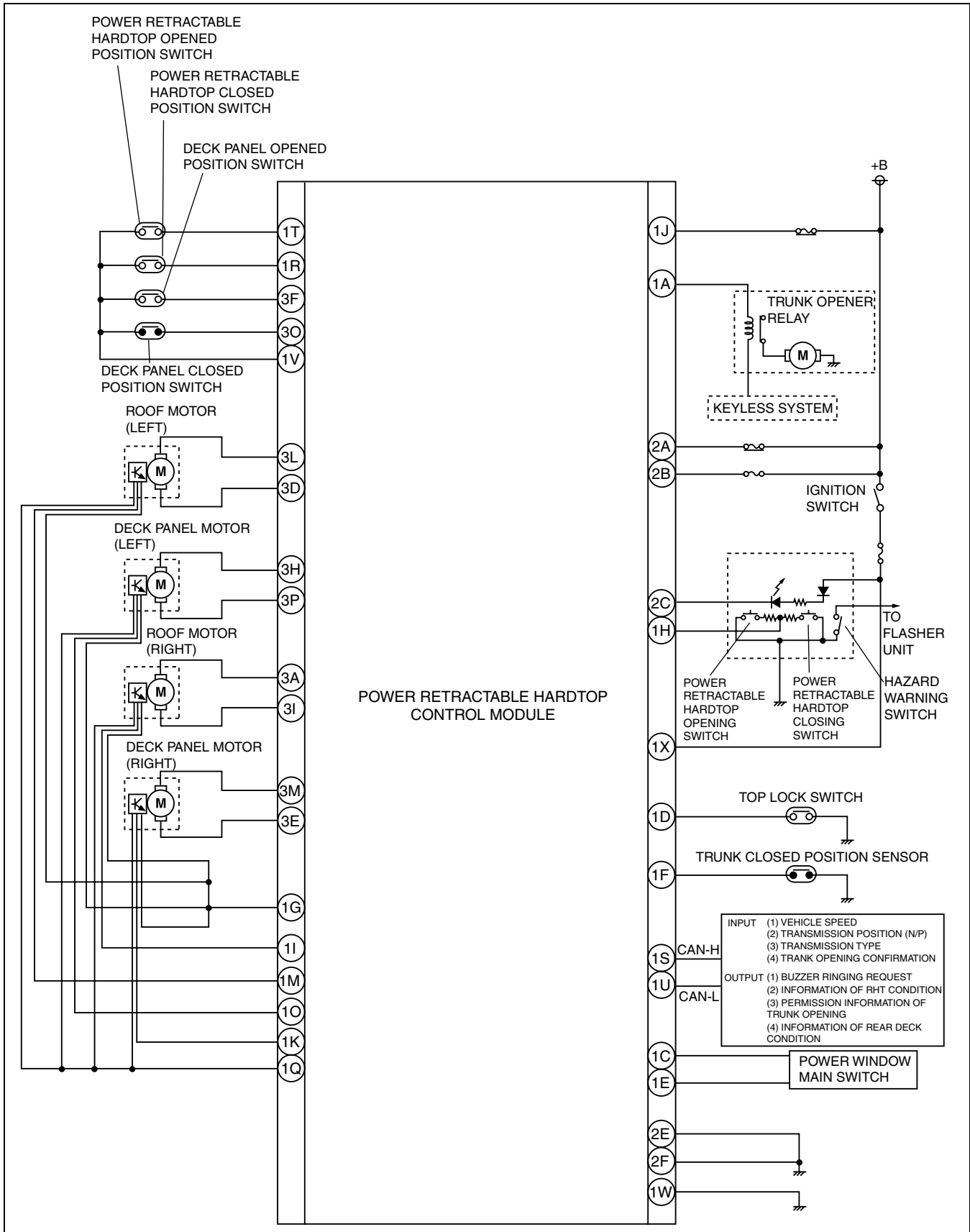

amxuun0000005

**Mazda MX-5**

# EXTERIOR TRIM

## POWER RETRACTABLE HARDTOP SYSTEM OPERATION

id091600101300

### Operation Conditions

- The Power retractable hardtop operates when all of the following conditions are met.
  - Ignition switch is in the ON position
  - The trunk lid is in the fully closed position.
  - The selector lever is in the P or N position (A/T).
  - The shift lever is in the neutral position (When the neutral switch is ON) (M/T).
  - The vehicle speed is **3 km/h {1.86 mph} or less.**
  - The power supply voltage is between 8.5 to 16.5 V.
  - The top lock switch is unlocked.

### Power Retractable Hardtop Operation Open operation timing chart

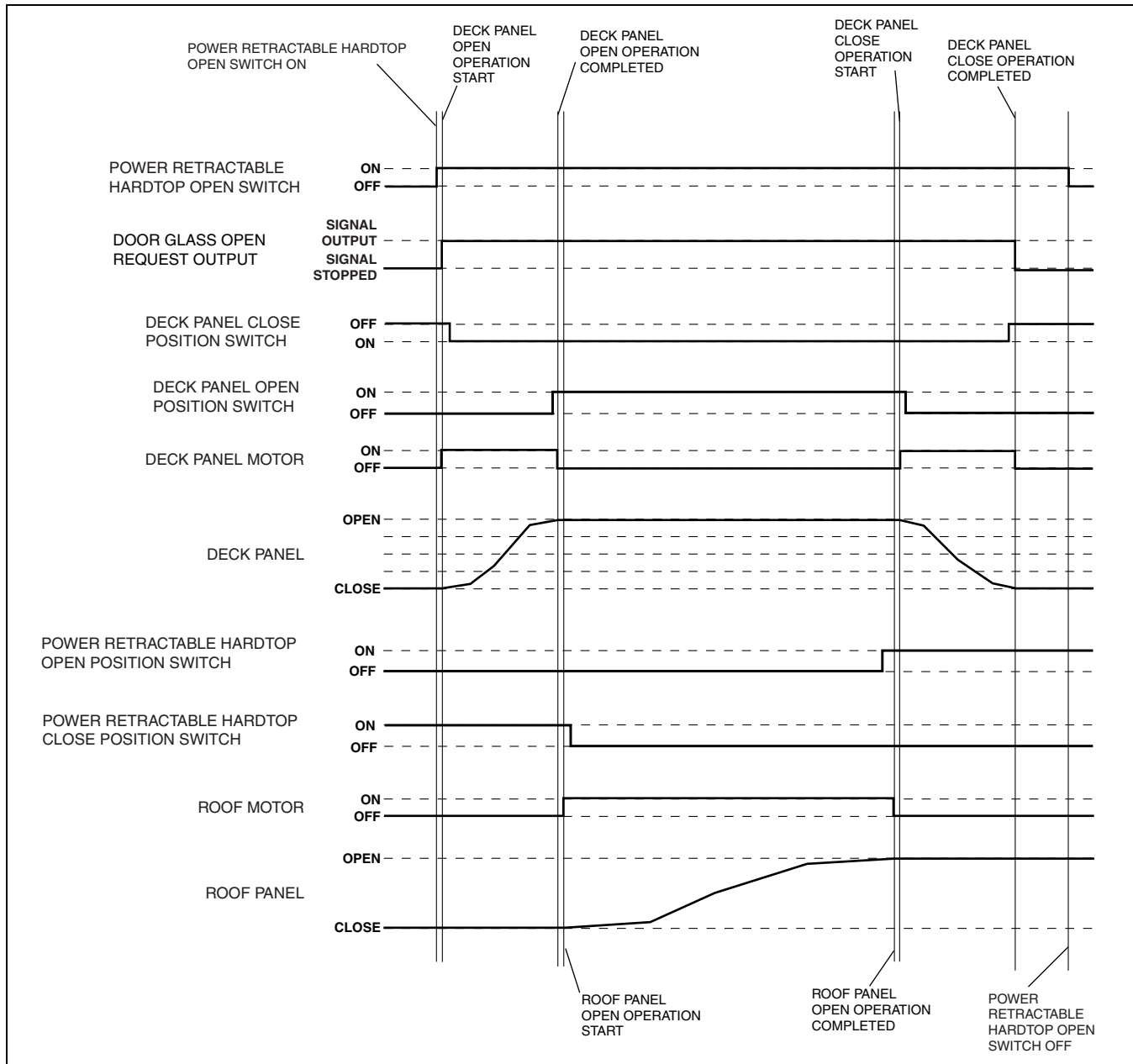

amxuun000005

- Pauses depending on the operation the same as the close operation timing chart.

## EXTERIOR TRIM

### Open operation

1. When the Power retractable hardtop open switch is turned on with all the Power retractable hardtop operation conditions met, the Power retractable hardtop open request signal is sent to the Power retractable hardtop control module.
2. The Power retractable hardtop control module confirms the operation conditions when it receives the signal, and if all the conditions are met, it sends an operation start beep signal to the instrument cluster.
3. The window glass open request signal is sent to the power window main switch.
4. When the door glass lowers approx. 100 mm, the deck panel motor operates and the deck panel moves in the open direction.
5. When the deck panel link pin contacts the deck panel open position switch and the switch is turned on, the deck panel is determined to be fully open and the deck panel motor stops.

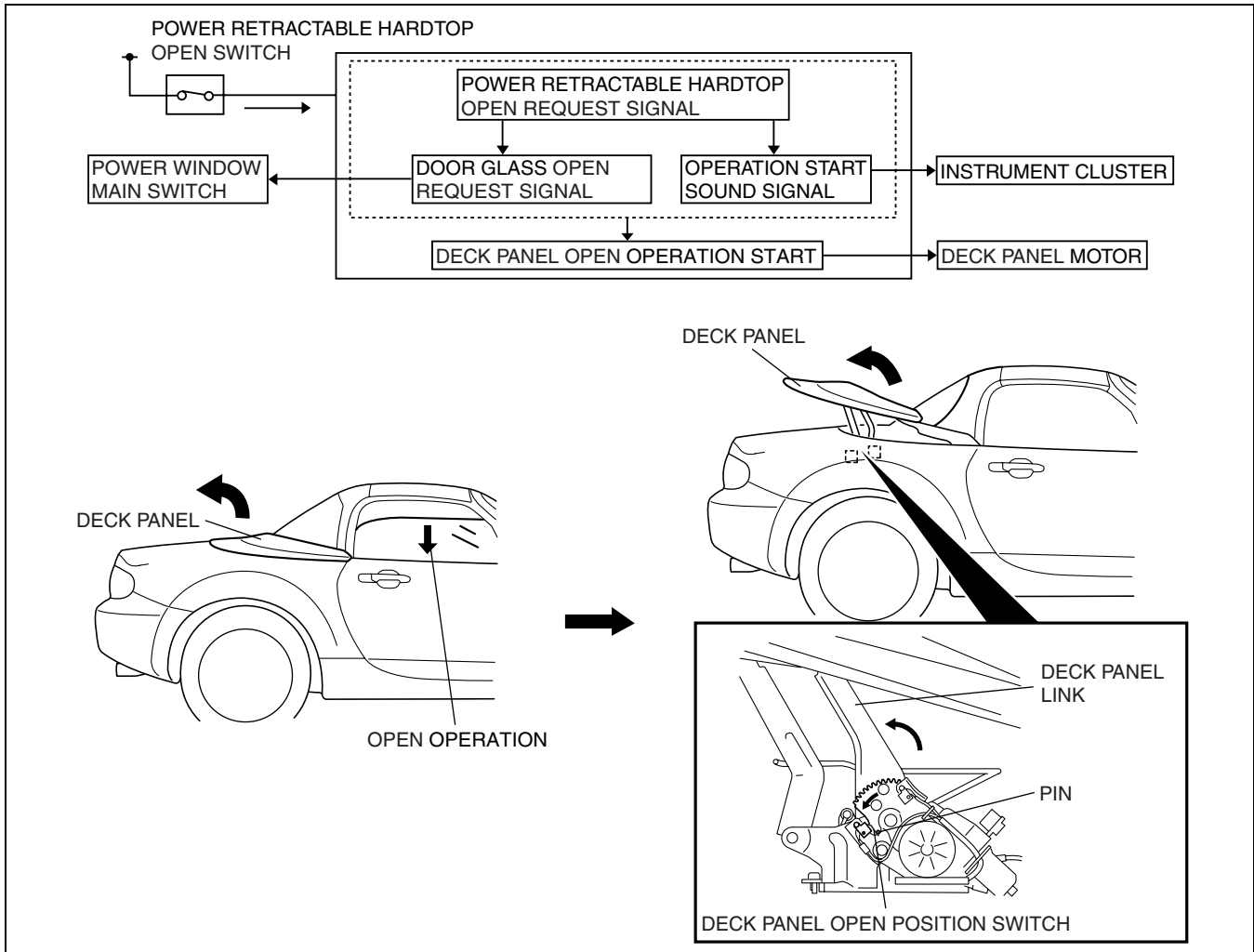

amxuun000005

6. The roof panel motor operates and the roof panel moves in the open direction.

## EXTERIOR TRIM

- When the roof panel link pin contacts the Power retractable hardtop open position switch and the switch is turned on, the roof panel is determined to be fully open and the roof panel motor stops.

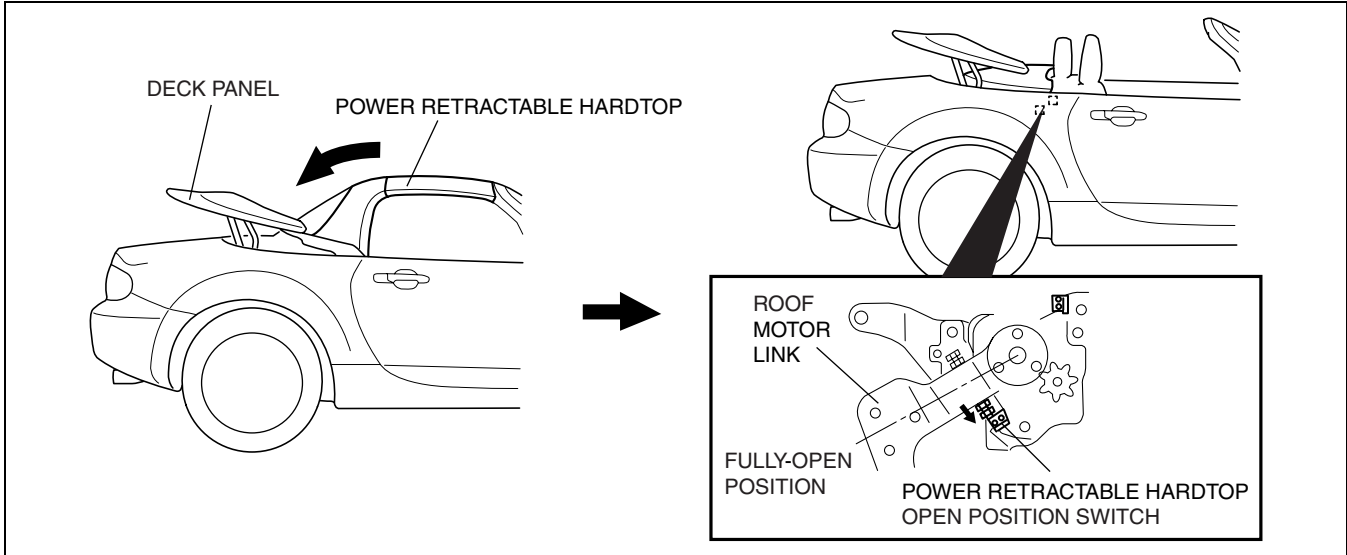

amxuun000004

- The deck panel motor operates and the deck panel moves in the close direction.
- Because link A rotates in the direction of the arrow due to the deck panel motor rotation, the roof hook cable is pulled and the roof hook is locked.

## EXTERIOR TRIM

10. When the deck panel link pin contacts the deck panel close switch and the switch is turned off, the deck panel is determined to be fully closed and the deck panel motor stops.

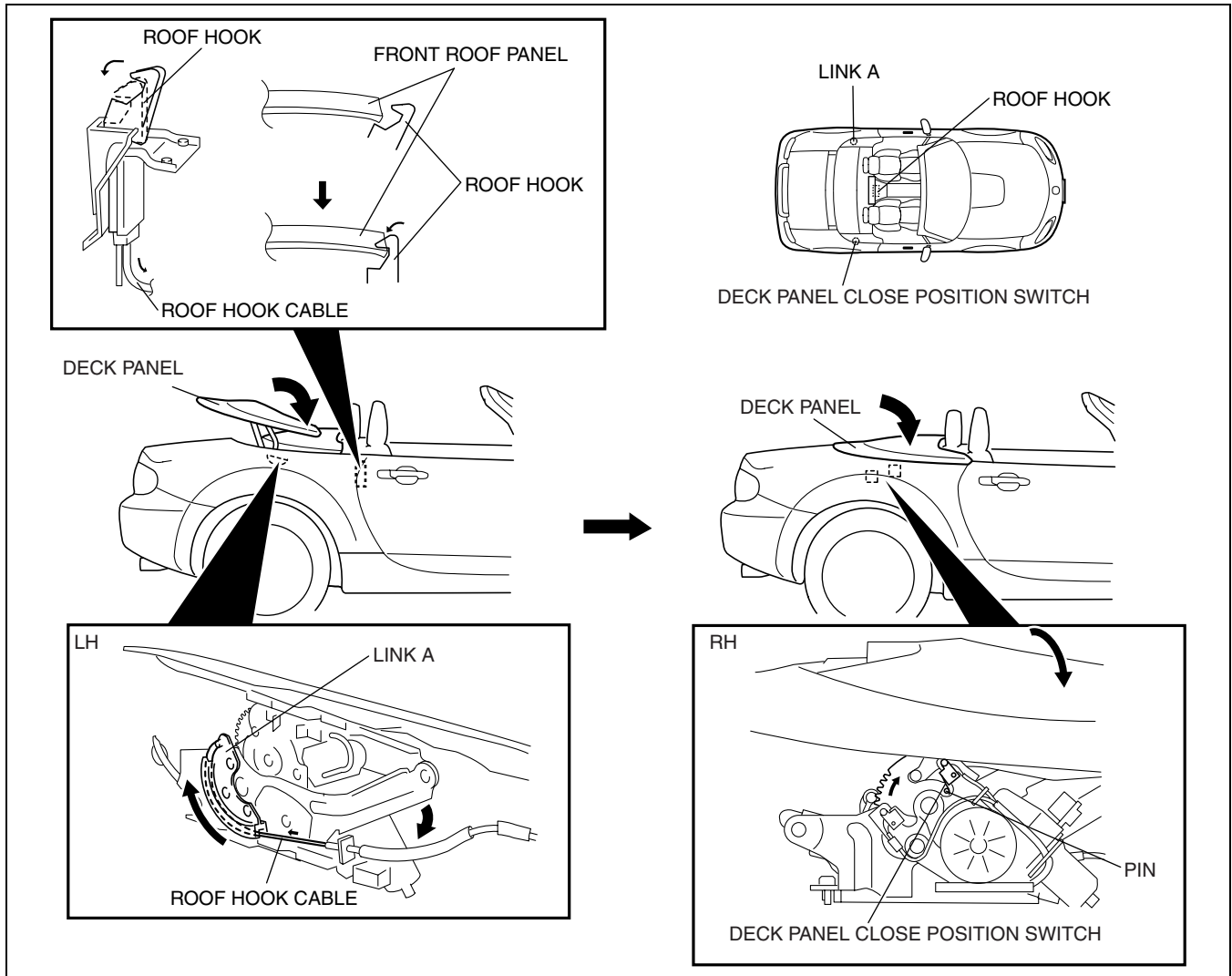

11. When the Power retractable hardtop open operation is finished, an operation finish beep signal is sent to the instrument cluster.

# EXTERIOR TRIM

## Close operation timing chart

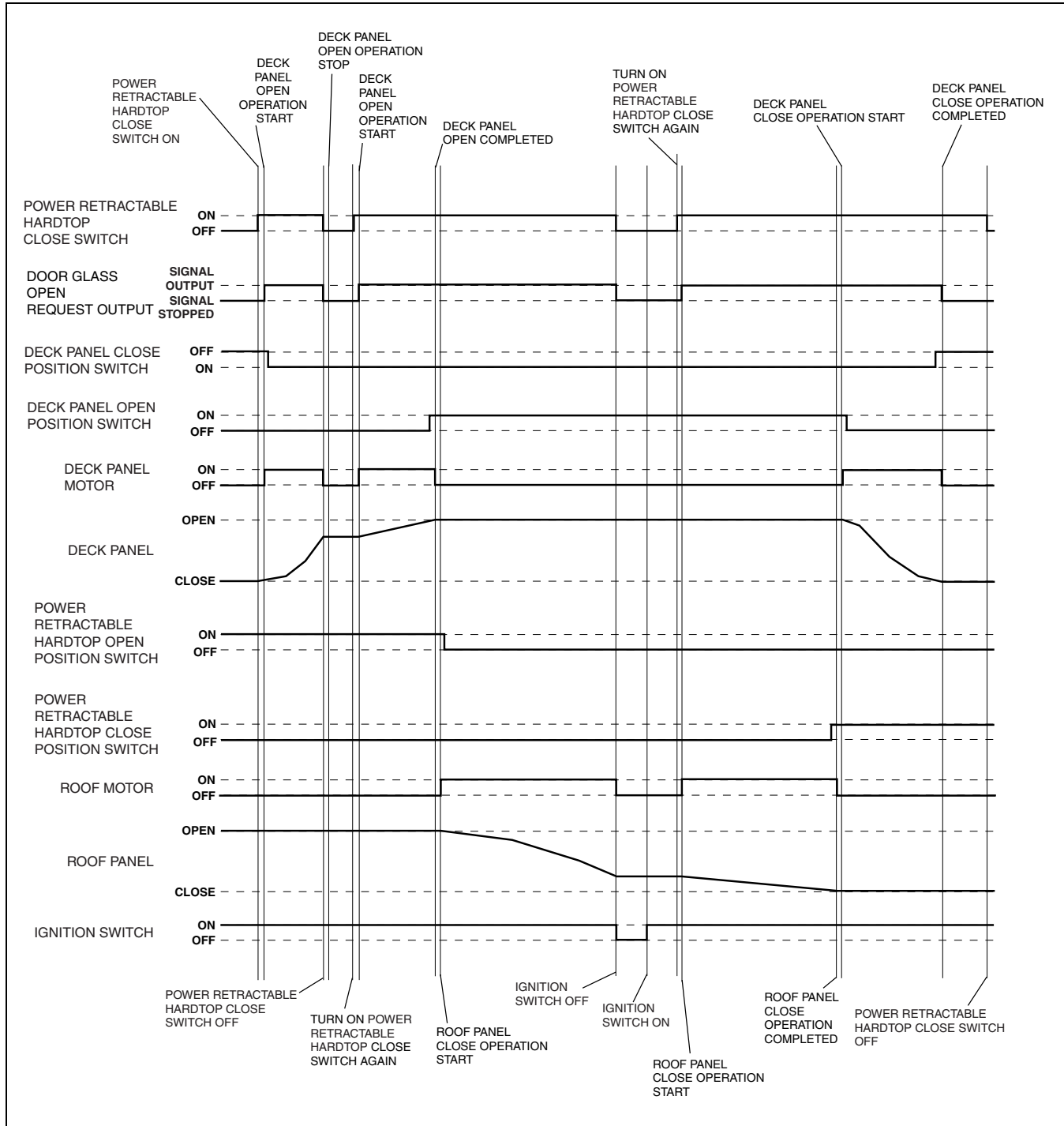

amxuun000004

## EXTERIOR TRIM

### Close operation

1. When the Power retractable hardtop close switch is turned on with all the Power retractable hardtop operation conditions met, Power retractable hardtop close request signal is sent to the Power retractable hardtop control module.
2. The Power retractable hardtop control module confirms the operation conditions when it receives the signal, and if all the conditions are met, it sends an operation start beep signal to the instrument cluster.
3. The window glass open request signal is sent to the power window main switch.
4. When the door glass lowers approx. 100 mm, the deck panel motor operates and the deck panel moves in the open direction.
5. Because link A rotates in the direction of the arrow due to the deck panel motor rotation, the roof hook cable loosens and the roof hook is unhooked.
6. When the deck panel link pin contacts the deck panel open position switch and the switch is turned on, the deck panel is determined to be fully open and the deck panel motor stops.

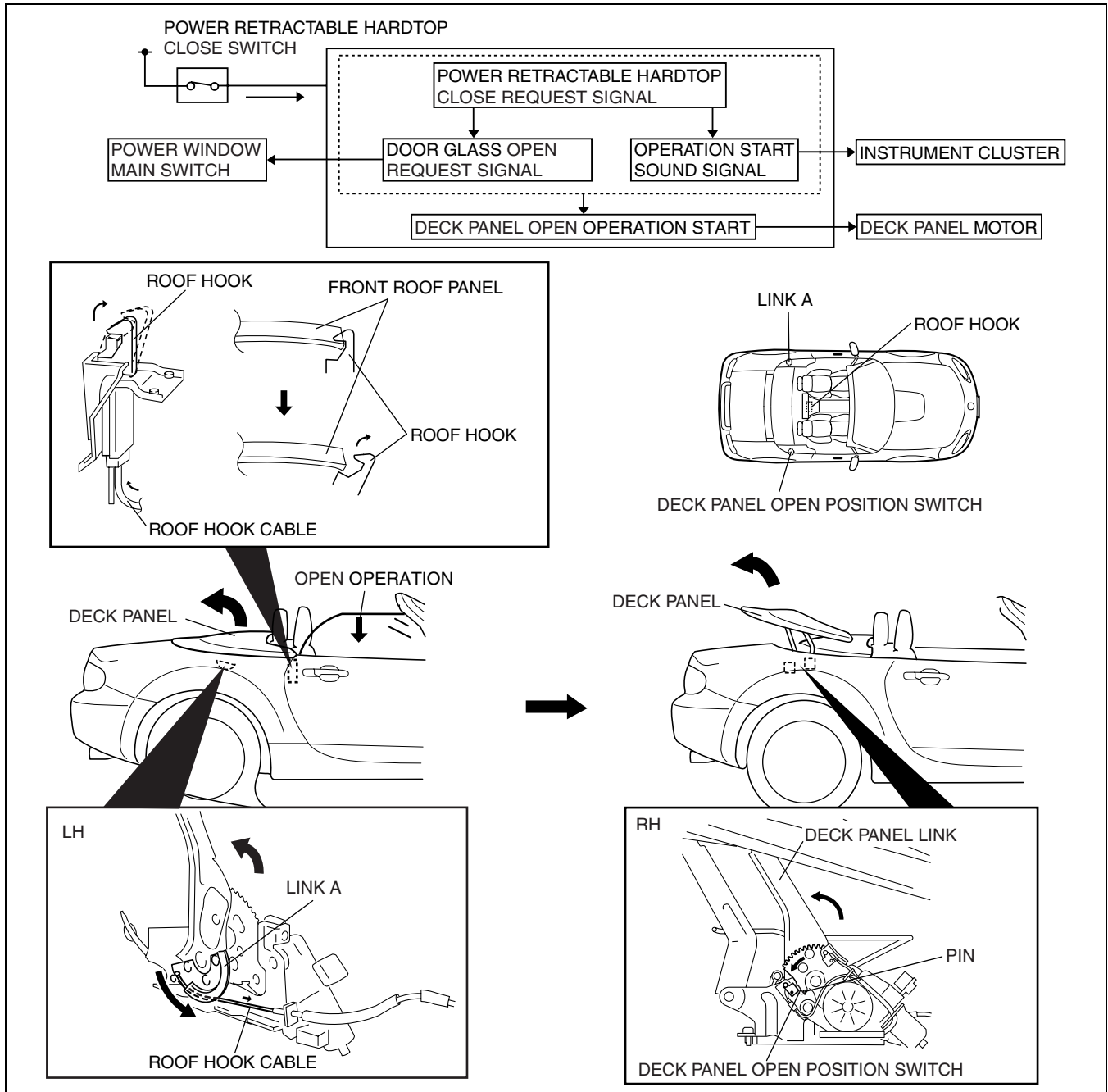

amxuun000004

7. The roof panel motor operates and the roof panel moves in the close direction.

## EXTERIOR TRIM

8. When the roof panel link pin contacts the Power retractable hardtop close position switch and the switch is turned on, the roof panel is determined to be fully closed and the roof panel motor stops.

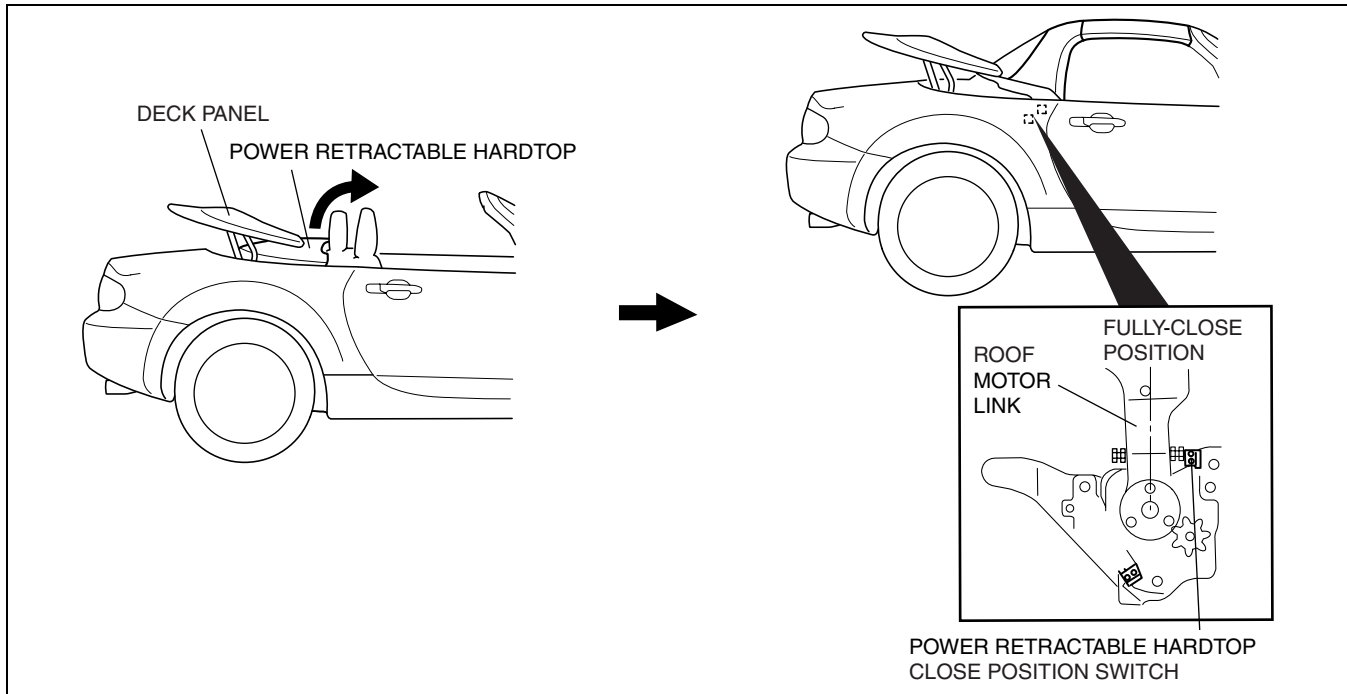

amxuun000005

9. The deck panel motor operates and the deck panel moves in the close direction.  
10. When the deck panel link pin contacts the deck panel close switch and the switch is turned off, the deck panel is determined to be fully closed and the deck panel motor stops.  
11. When the Power retractable hardtop close operation is finished, an operation finish beep signal is sent to the instrument cluster.

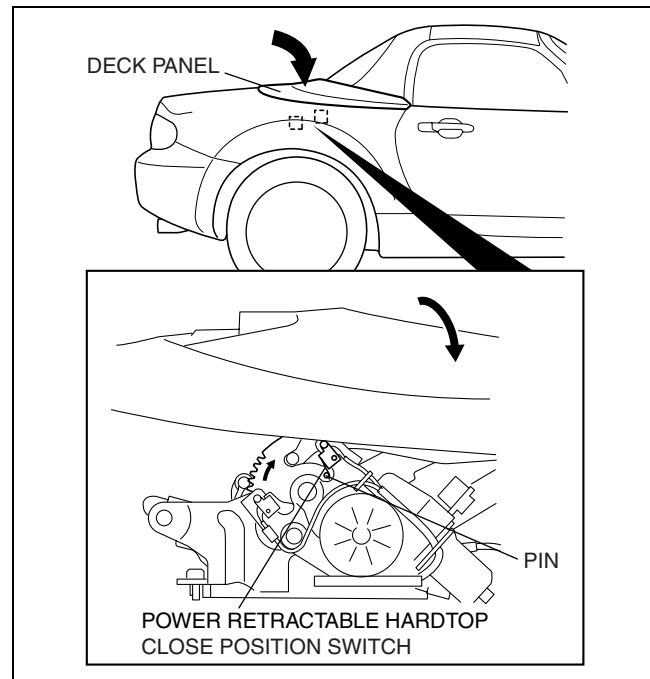

amxuun000003

### POWER RETRACTABLE HARDTOP CONTROL MODULE FUNCTION

id091600101400

- Controls the Power retractable hardtop control module, roof motor, and the deck panel motor based on the signals from each switch.
- A fail-safe function has been adopted which stops the operation if an abnormal signal is detected from any part during Power retractable hardtop operation.
- A self-diagnostic function has been adopted which can verify the malfunctioning area.

## EXTERIOR TRIM

### FAIL-SAFE FUNCTION

- The power retractable hardtop control module monitors each input/output part, and if a malfunction is detected, performs the following actions.

Item	Detection Condition	Action after malfunction detected	Recovery condition
Power supply voltage error	Power supply voltage is 7.5 V or less, or 17.5 V or more.	<ul style="list-style-type: none"> <li>Power retractable hardtop not operated → Inhibits Power retractable hardtop operation</li> <li>Power retractable hardtop operating → Stops Power retractable hardtop operation</li> </ul>	Power supply voltage is between 8.5 to 16.5 V.
Roof/deck panel motor Hall sensor power supply voltage error	Sensor power supply voltage is 5 V or less.	Stops motor operation	The ignition switch is turned from the ON position in the following order. <ul style="list-style-type: none"> <li>OFF → ON</li> </ul>
Roof/deck panel motor Hall sensor malfunction	Roof/deck panel motor Hall sensor pulse signal cannot be detected.	Temporarily stops the operation, however, the operation can be performed by turning on the Power retractable hardtop switch again.	Pulse signal detected
Door glass open notification signal error	Door glass open notification signal cannot be detected.	<ul style="list-style-type: none"> <li>If the signal is detected during the Power retractable hardtop close operation, inhibits the operation after the Power retractable hardtop is fully closed. (Only deck panel can operate.)</li> <li>If the signal is detected during the Power retractable hardtop open operation, the open operation continues and after the operation finishes, the close operation can be performed only once. Inhibits the operation after the Power retractable hardtop is fully closed. (Only deck panel can operate.)</li> </ul>	Door glass open notification signal can be detected.
	Open notification signal is received continuously for 30 s or more.	<ul style="list-style-type: none"> <li>If the signal is detected with the Power retractable hardtop fully closed and not operating, inhibits the operation.</li> <li>If the signal is detected with the Power retractable hardtop fully open and not operating, the Power retractable hardtop close operation can be performed only once. Inhibits the operation after the Power retractable hardtop is fully closed.</li> </ul>	Continuous reception of the open notification signal stops temporarily.
Roof/deck panel motor malfunction	Supply voltage to the motor is lowered.	Stops motor operation	The ignition switch is turned from the ON position in the following order. <ul style="list-style-type: none"> <li>OFF → ON</li> </ul>
Roof motor (Left and right position combination)	Difference in pulse count number between left and right is at a certain level or more.	Stops motor operation	Power retractable hardtop switch is operated again. However, if detected three times or more, the ignition switch is turned from the ON position in the following order. <ul style="list-style-type: none"> <li>OFF → ON</li> </ul>
Deck panel motor (Left and right position combination)	Difference in pulse count number between left and right is at a certain level or more.	Stops motor operation	Power retractable hardtop switch is operated again. However, if detected three times or more, the ignition switch is turned from the ON position in the following order. <ul style="list-style-type: none"> <li>OFF → ON</li> </ul>
Power retractable hardtop/deck panel limit switch malfunction	The Power retractable hardtop/deck panel limit switch is malfunctioning.	Inhibits Power retractable hardtop operation.	Normal logic is detected.

## EXTERIOR TRIM

Item	Detection Condition	Action after malfunction detected	Recovery condition
Top lock switch malfunction	Top lock switch on is detected with the Power retractable hardtop open.	Close operation can be performed only once. Inhibits the operation after the Power retractable hardtop is fully closed.	Top lock switch off is detected.
	Top lock switch off is detected with the Power retractable hardtop closed and vehicle speed detected.	None	Vehicle speed 0 km/h is detected.
Power retractable hardtop switch malfunction	Switch input is 1 V or less.	Inhibits Power retractable hardtop operation.	Normal input voltage is recovered.
	Switch on signal is detected for 30 s or more after IG-ON.	Inhibits Power retractable hardtop operation.	Power retractable hardtop switch off signal is detected.
	Power retractable hardtop open and close on signals are detected simultaneously for 30 s or more.	Inhibits Power retractable hardtop operation.	Power retractable hardtop switch off signal is detected.
Communication error	CAN system of the Power retractable hardtop control module is malfunctioning.	Inhibits Power retractable hardtop operation.	Normal communication is recovered.
	CAN communication error between PCM and Power retractable hardtop control module	Inhibits Power retractable hardtop operation.	Normal communication is recovered.
	CAN communication error between TCM and Power retractable hardtop control module	Inhibits Power retractable hardtop operation.	Normal communication is recovered.
	Vehicle speed signal error	Inhibits Power retractable hardtop operation.	Normal communication is recovered.

### Buzzer operation function

- Sends beep signals to the instrument cluster before and after the Power retractable hardtop system operation, when the operation is refused, and during an operation warning. (See 09-22-2 POWER RETRACTABLE HARDTOP WARNING ALARM CONSTRUCTION/OPERATION.)

### Power retractable hardtop indicator light control

- Sends illumination or flash signal to the power retractable hardtop indicator light in the following pattern depending on the Power retractable hardtop status.

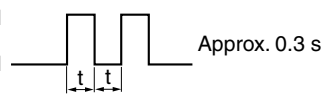
	Illumination pattern	Illumination condition	Lights off condition
Power retractable hardtop operating	<p>Illuminated </p> <p>Not illuminated</p>	Power retractable hardtop operation is continued.	<ul style="list-style-type: none"> <li>Open operation is finished.</li> <li>Close operation is finished</li> </ul>
Power retractable hardtop half-open and not operating	<p>Illuminated _____</p> <p>Not illuminated</p>	<ul style="list-style-type: none"> <li>Power retractable hardtop is fully opened and the top lock is unlocked. (Top lock switch is OFF.)</li> <li>Power retractable hardtop switch is turned off during Power retractable hardtop operation and the operation is temporarily stopped.</li> </ul>	<ul style="list-style-type: none"> <li>Power retractable hardtop switch is turned on.</li> <li>Top lock is locked after close operation is finished.</li> </ul>
Power retractable hardtop system malfunctioning	<p>Illuminated </p> <p>Not illuminated</p>	DTC is detected or recorded. (The power retractable hardtop indicator light does not illuminate depending on the DTC.) (The power retractable hardtop indicator light does not illuminate depending on the DTC.) (See 09-16-19 ON-BOARD DIAGNOSTIC PID DATE MONITOR FUNCTION.)	<ul style="list-style-type: none"> <li>Malfunction is repaired or the DTC is cleared.</li> </ul>

## EXTERIOR TRIM

### POWER RETRACTABLE HARDTOP LINK CONSTRUCTION/OPERATION

id091600101500

#### Construction

- Installed to the inside of the Power retractable hardtop.
- The front roof panel is installed to the front roof panel link.
- The middle roof panel is installed to the middle roof panel link and roof motor link.
- The roof motor link gear is integrated with the roof motor link.
- The rear window glass is installed to rear window glass link A.
- The Power retractable hardtop fully opens/closes via the rotation of each link in conjunction with the roof motor rotation.

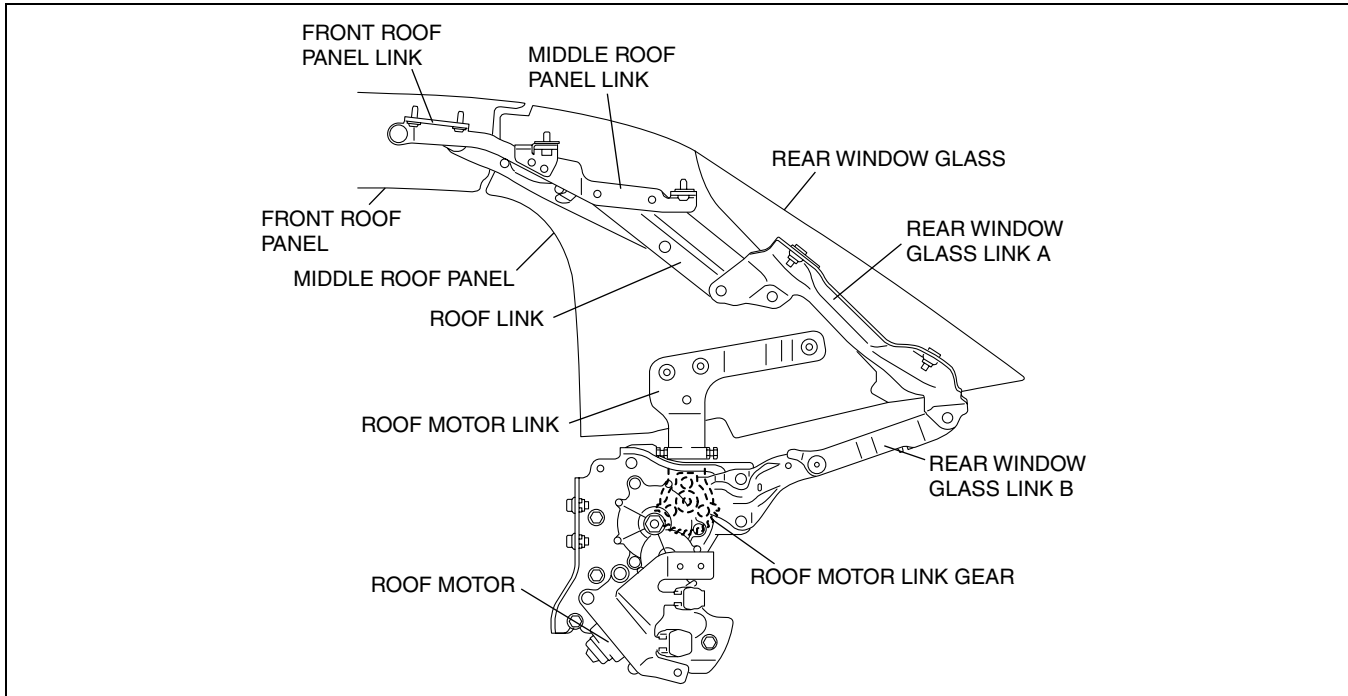

amxuun0000005

# EXTERIOR TRIM

## Operation

### Open operation

1. After the deck panel is fully opened, the roof motor starts rotating based on the operation signal from the Power retractable hardtop control module.
2. The roof motor link gear and the roof motor link start rotating due to the roof motor rotation, and at the same time, the middle roof panel and the middle roof panel link rotate.
3. The front roof panel link and rear window glass link B rotate due to the middle roof panel link rotation.
4. Rear window glass link A rotates faster than the middle roof panel link at pivot fulcrum A, rear window glass link A moves downward, and the rear window glass moves in the inner side of the middle roof panel.
5. Due to the rotation of the roof link at pivot fulcrum B, the middle roof panel, rear window glass, and the front roof panel move to the fully-open position.
6. When the roof motor link rotates to the fully-open position, a part of the roof motor link shown in the figure presses the Power retractable hardtop open position switch stopping the roof motor rotation.

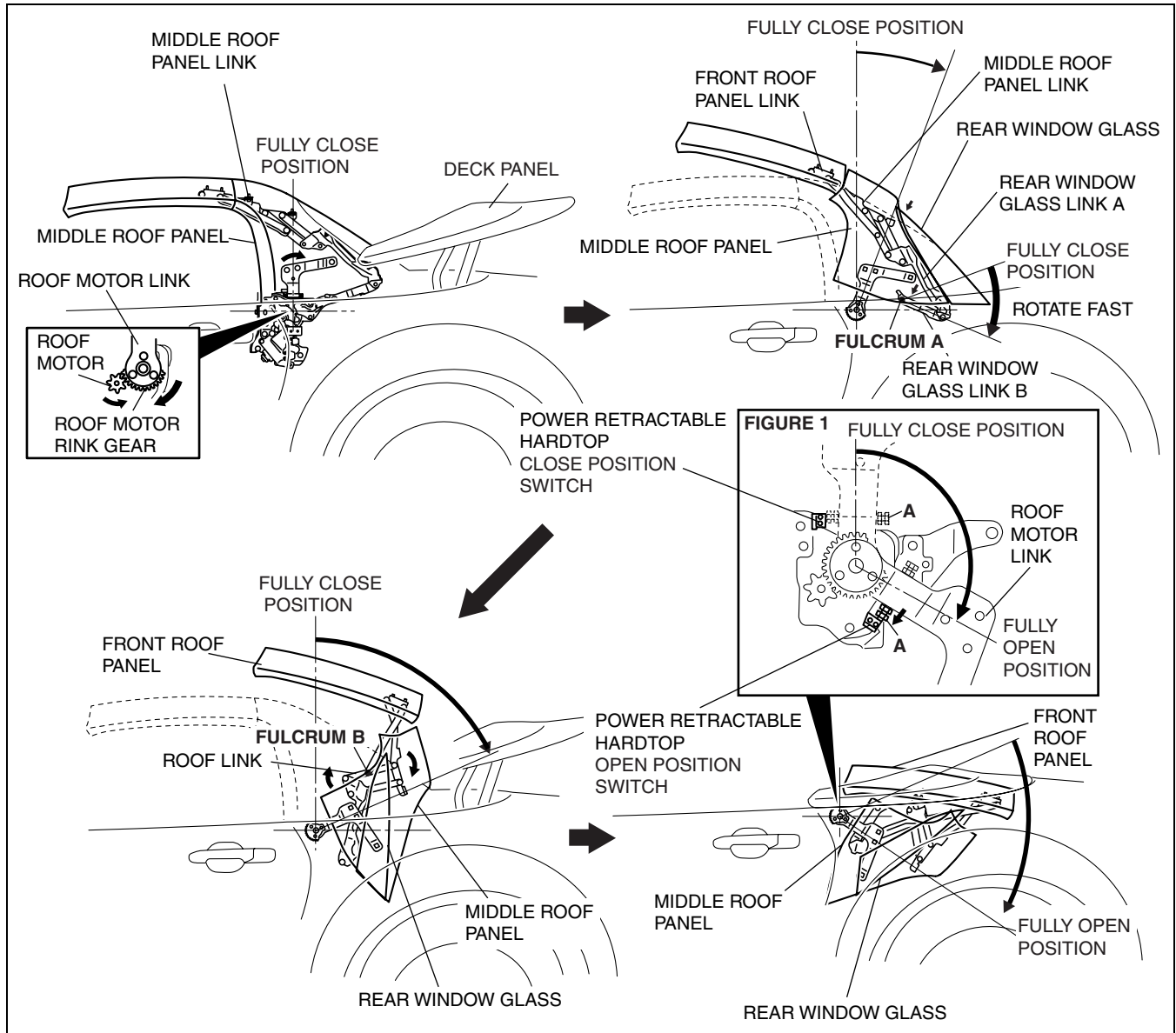

amxuun000005

# EXTERIOR TRIM

## DECK PANEL LINK CONSTRUCTION/OPERATION

id091600101600

### Construction

- The links rise according to the rotation of the deck panel links to fully open or close the deck.
- The deck panel limit switch is installed to the deck panel link (RH).
- The guide for the deck panel manual open/close is installed to the deck panel base link. (Refer to the Workshop Manual for the procedure.)

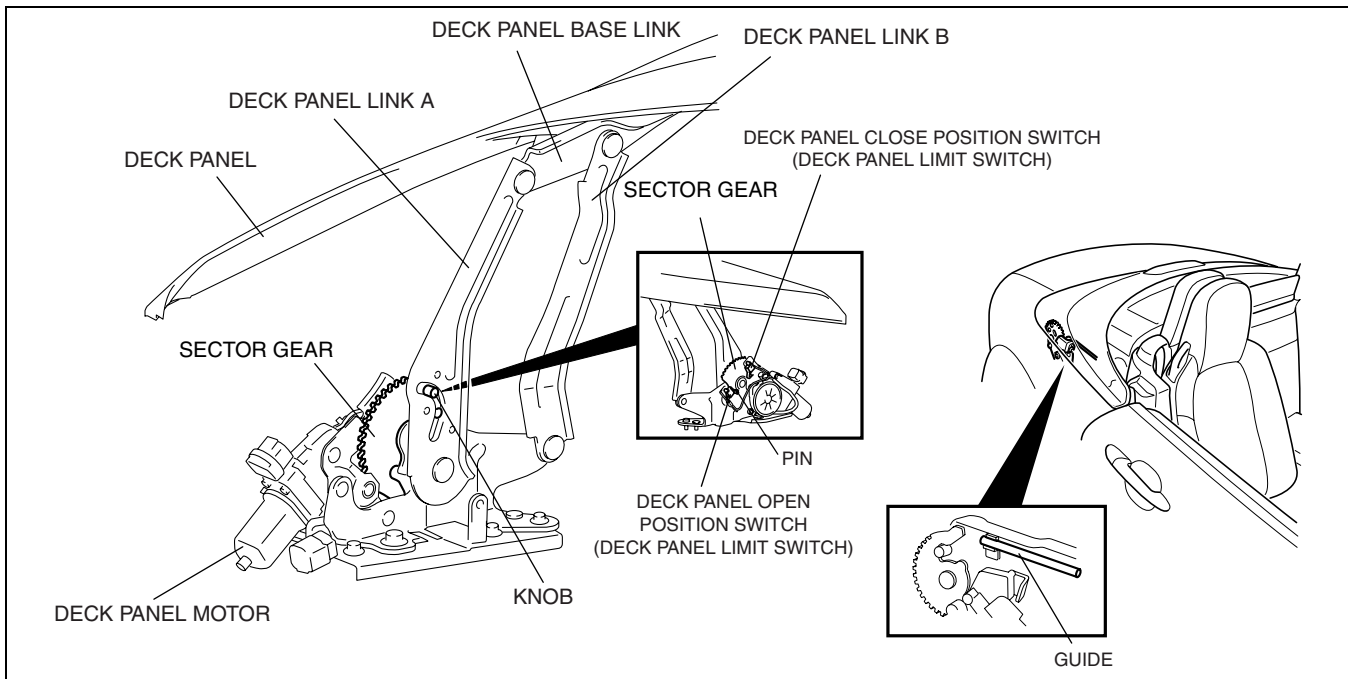

amxuun0000005

### Operation

1. The deck panel motor starts to rotate based on an operation signal of the power retractable hardtop control module.
2. The sector gear rotates according to the deck panel motor rotation, and the lock pin area of the deck panel base link and sector gear are disengaged.

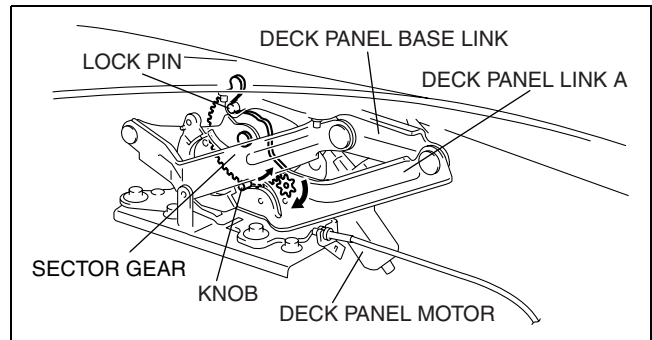

amxuun0000001

3. The knob presses deck panel link A upward by the rotation of the sector gear.

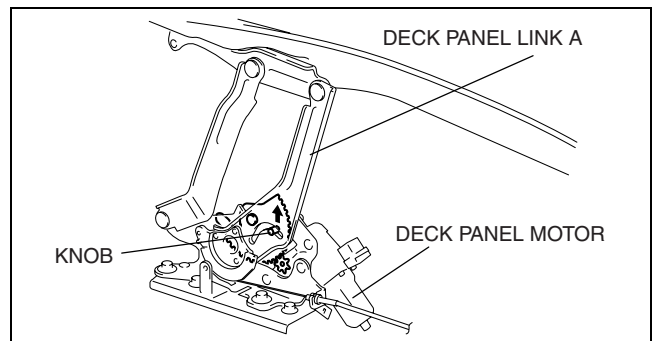

amxuun0000005

Mazda MX-5

## EXTERIOR TRIM

- Deck panel link A is pressed upward to fully open the deck panel.

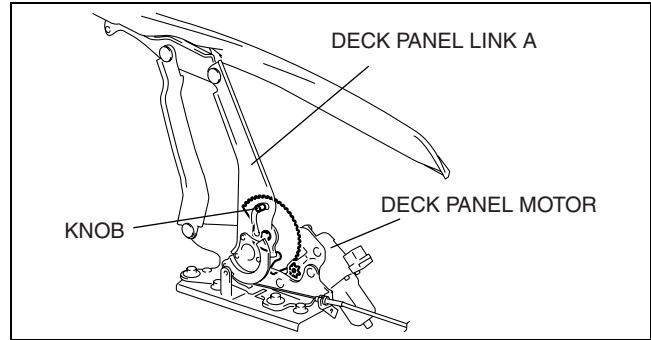

amxuun0000005

- When deck panel link A is fully opened, the sector gear pin shown in the figure presses the deck panel open position switch to stop the deck panel motor rotation.

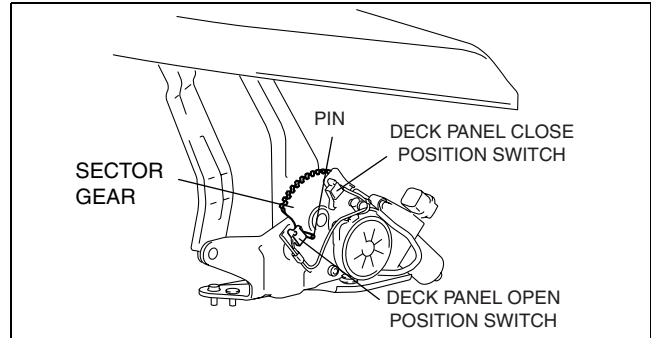

amxuun00000060

### ROOF/DECK PANEL MOTOR FUNCTION

id091600101700

- The motor rotates normally/reversely according to the signal from the power retractable hardtop control module to move the roof panel automatically.

## EXTERIOR TRIM

### ROOF/DECK PANEL MOTOR CONSTRUCTION

id091600101800

- Consists of a motor, connector, and gear.
- Two Hall effect switches are located in the connector.
- In the connector, the roof motor has one Hall effect switch and the deck panel motor has two (only one Hall effect switch is used). (The Hall effect switch does not detect rotation direction.)
- Hall effect switch 1 outputs one pulse cycle for each rotation of the motor axle and the power retractable hardtop control module detects motor rotation speed from this.

#### Roof panel motor construction view

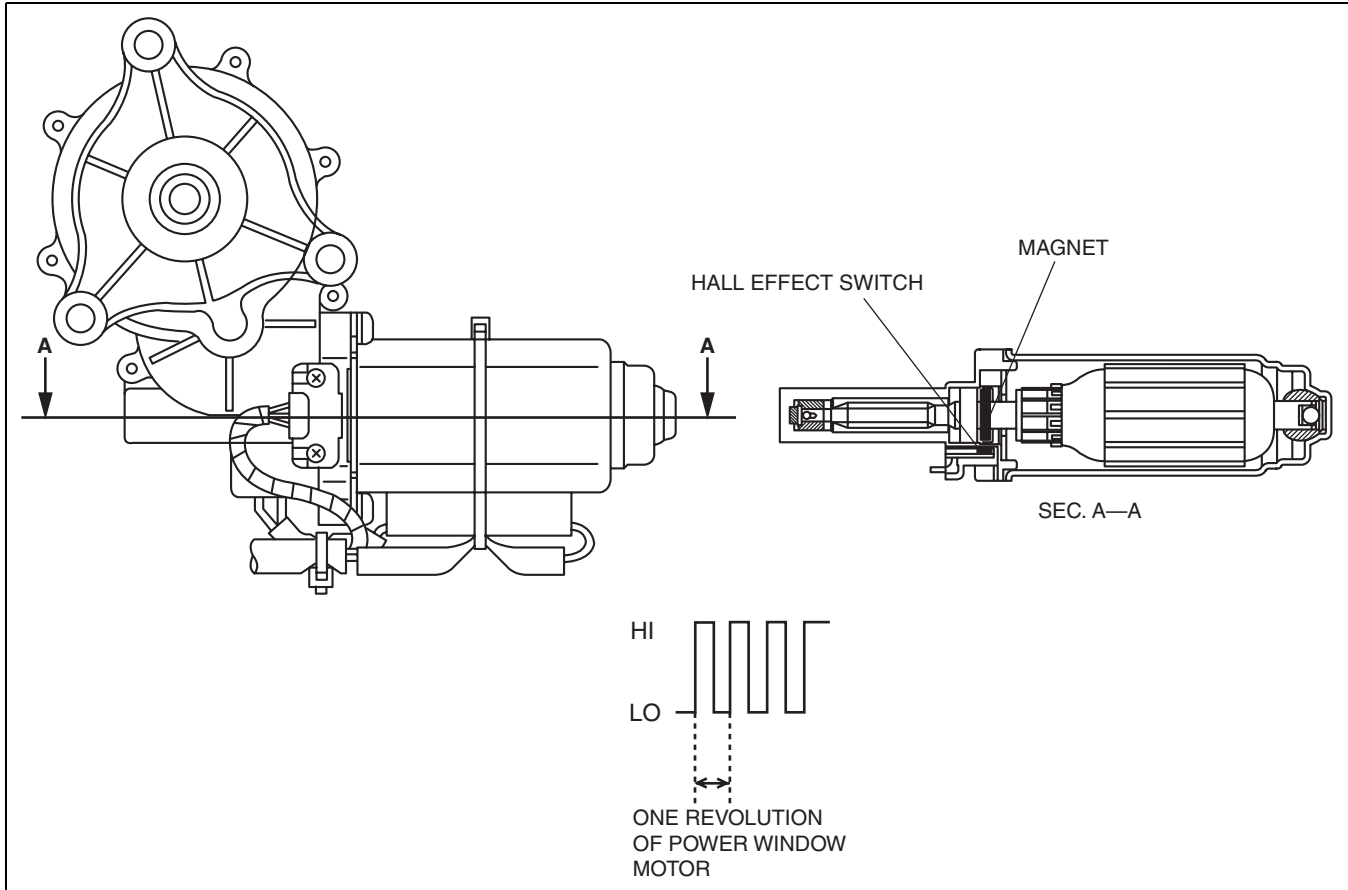

amxuun0000004

# EXTERIOR TRIM

## Deck panel motor construction view

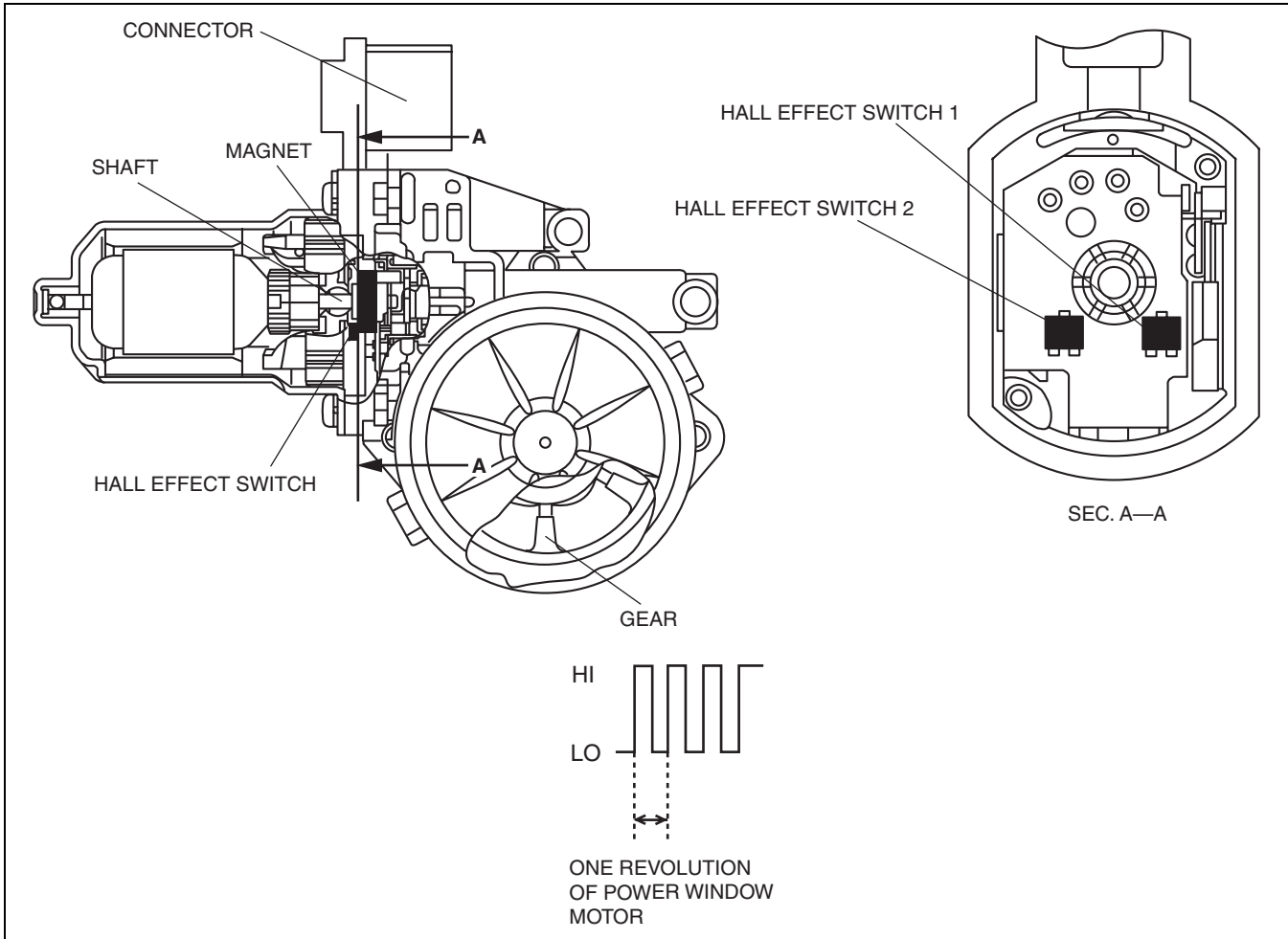

amxuun000004

## POWER RETRACTABLE HARDTOP SWITCH OUTLINE

id091600101900

- The power retractable hardtop electric open/close operation is performed by the power retractable hardtop open and close switches.

## POWER RETRACTABLE HARDTOP SWITCH CONSTRUCTION/OPERATION

id091600102000

- The power retractable hardtop switch is integrated with the hazard warning switch.
- The operational switch operates at the point the switch has been continuously pressed on for 100 ms.
- Depending on the power retractable hardtop position and operation conditions, the operation switch input reception is restricted as follows:

Power retractable hardtop position		Power retractable hardtop open switch input	Power retractable hardtop close switch input	Power retractable hardtop operation after switch determined to be on/off	Restriction
Power retractable hardtop position	Power retractable hardtop operation				
Full open	Stopped	ON	OFF	Stop	power retractable hardtop open switch inoperative
Full closed	Stopped	OFF	On operation	Stop	power retractable hardtop close switch inoperative
All positions	Stopped	ON at the same time	ON at the same time	Stop	power retractable hardtop open and close switch inoperative
Full open	Stopped	During ON	Operates afterward	Stop	power retractable hardtop close switch inoperative
Full closed	Stopped	Operates afterward	During ON	Stop	power retractable hardtop open switch inoperative

## EXTERIOR TRIM

Power retractable hardtop position		Power retractable hardtop open switch input	Power retractable hardtop close switch input	Power retractable hardtop operation after switch determined to be on/off	Restriction
Power retractable hardtop position	Power retractable hardtop operation				
Except fully open	During open operation	During ON	On operation afterward	operations stop	power retractable hardtop open and close switch inoperative
Except fully closed	During close operation	On operation afterward	During ON	operations stop	power retractable hardtop open and close switch inoperative

- Once the operation switch has operated, the next operation switch does not operate unless an off-operation for the switch operation is detected.

### ON-BOARD DIAGNOSTIC OUTLINE

id091600102100

#### Special Features

- The power retractable hardtop has an on-board diagnostic function to facilitate system diagnosis.
- The on-board diagnostic function consists of the following functions: a malfunction detection function, which detects overall malfunctions in the power retractable hardtop-related parts; a memory function, which stores detected DTCs; a display function, which indicates system malfunctions by DTC display; and a PID/data monitoring function, which reads out specific input/output signals.
- Using the Mazda modular diagnostic system (M-MDS), DTCs can be read out and cleared, and the PID/data monitoring function can be activated.

### ON-BOARD DIAGNOSTIC PID DATE MONITOR FUNCTION

id091600102200

#### On-board Diagnostic Function Malfunction detection function

- Detects overall malfunctions in the power retractable hardtop-related parts.

#### Memory function

- Stores malfunctions in the power retractable hardtop-related parts detected by the malfunction detection function, and the stored malfunction contents are not cleared even if the ignition switch is turned to the LOCK position or the negative battery cable is disconnected.

#### DTC table

DTC	Description	Malfunction indication	
		Buzzer sound	Power retractable hardtop indicator light flashing
B1342	Power retractable hardtop control module internal malfunction	None	None
B1317	Battery power supply voltage increases (17.5 V or more)	Operation reject sound*1	Flashing pattern for a power retractable hardtop malfunction*1
B1318	Battery power supply voltage decreases (less than 7.5 V)	Operation reject sound*1	Flashing pattern for a power retractable hardtop malfunction*1
B296D	Hall sensor low power supply voltage	Operation reject sound	Flashing pattern for a power retractable hardtop malfunction
U0030	Door glass communication error (during power retractable hardtop operation)	None	Flashing pattern for a power retractable hardtop malfunction
U0031	Door glass communication error (during power retractable hardtop not operation)	None	Flashing pattern for a power retractable hardtop malfunction
B296A	Roof motor pulse signal error (RH)	Operation reject sound	Flashing pattern for a power retractable hardtop malfunction
U294B	Roof motor pulse signal error (LH)	Operation reject sound	Flashing pattern for a power retractable hardtop malfunction

## EXTERIOR TRIM

DTC Mazda modular diagnostic system (M- MDS) display	Description	Malfunction indication	
		Buzzer sound	Power retractable hardtop indicator light flashing
B293C	Deck panel motor pulse signal error (RH)	Operation reject sound	Flashing pattern for a power retractable hardtop malfunction
B293B	Deck panel motor pulse signal error (LH)	Operation reject sound	Flashing pattern for a power retractable hardtop malfunction
B293E	Roof motor circuit malfunction (RH)	Operation reject sound	Flashing pattern for a power retractable hardtop malfunction
B293D	Roof motor circuit malfunction (LH)	Operation reject sound	Flashing pattern for a power retractable hardtop malfunction
B294C	Deck panel motor circuit malfunction (RH)	Operation reject sound	Flashing pattern for a power retractable hardtop malfunction
B293F	Deck panel motor circuit malfunction (LH)	Operation reject sound	Flashing pattern for a power retractable hardtop malfunction
B294D	Roof motor opening angle does not match (Pulse count number do not match)	Operation reject sound	Flashing pattern for a power retractable hardtop malfunction
B294E	Deck panel motor opening angle does not match (Pulse count number do not match)	Operation reject sound	Flashing pattern for a power retractable hardtop malfunction
B294F	Power retractable hardtop/deck panel limit switch malfunction	Operation reject sound* <sup>2</sup>	Flashing pattern for a power retractable hardtop malfunction
B296B	Top lock switch malfunction	None	Flashing pattern for a power retractable hardtop malfunction
B296C	Power retractable hardtop switch malfunction	Operation reject sound* <sup>2</sup>	Flashing pattern for a power retractable hardtop malfunction
U0073	CAN system communication error	Operation reject sound* <sup>2</sup>	Flashing pattern for a power retractable hardtop malfunction
U0100	Communication error to PCM	Operation reject sound* <sup>2</sup>	Flashing pattern for a power retractable hardtop malfunction
U0101	Communication error to TCM	Operation reject sound* <sup>2</sup>	Flashing pattern for a power retractable hardtop malfunction
U2197	Vehicle speed signal communication error	Operation reject sound* <sup>2</sup>	Flashing pattern for a power retractable hardtop malfunction

\*1 : No buzzer sound and power retractable hardtop indicator light illumination if the power retractable hardtop operation is inhibited while it is not operating.

\*2 : No buzzer sound except when the power retractable hardtop switch is turned on.

## EXTERIOR TRIM

### PID/Data Monitor Function

- The PID/data monitor function is used for optionally selecting input/output signal monitor items preset in the power retractable hardtop control module and reading them out in real-time.
- Use the mazda modular diagnostic system (M-MDS) to read the PID/data monitor.

### PID/data monitor table

PID name (definition)	Data contents	Unit/ Operation	Terminal
DTC_CNT	Number of continuous DTCs	–	–
VPWR	Module Supply Voltage	V	1X
VSS	Vehicle speed	MPH/KPH	–
RHT_OP	Power Retractable Hardtop Open Position Sensor	On/Off	1T
RHT_CL	Power Retractable Hardtop Closed Position Sensor	On/Off	1R
DECK_OP	Deck Open Position Sensor	On/Off	3F
DECK_CL	Deck Close Position Sensor	On/Off	3O
SW_OP	Power Retractable Hardtop Open Switch	On/Off	1H
SW_CL	Power Retractable Hardtop Close Switch	On/Off	1H
SW_STRIKER	Top Lock Switch	On/Off	1D
SW_TRUNK	Trunk Switch	On/Off	1F
TR_OP_CTL	Trunk Opener Control	On/Off	–
Indicator	power retractable hardtop Indicator Light	On/Off	2C



# 09-22 INSTRUMENTATION/DRIVER INFO.

**INSTRUMENT CLUSTER**

OUTLINE . . . . . 09-22-1

**INSTRUMENT CLUSTER**

SPECIFICATIONS . . . . . 09-22-1

**POWER RETRACTABLE HARDTOP**

WARNING ALARM OUTLINE . . . . . 09-22-1

**POWER RETRACTABLE HARDTOP**

**WARNING ALARM**

CONSTRUCTION/OPERATION . . . . . 09-22-2

System Wiring Diagram . . . . . 09-22-2

Operation . . . . . 09-22-2

**INSTRUMENT CLUSTER OUTLINE**

id092200100200

- Due to the adoption of the power retractable hardtop, the power retractable hardtop warning alarm has been added.

**INSTRUMENT CLUSTER SPECIFICATIONS**

id092200101100

Item		Specification	
<b>Warning alarms</b>			
Power retractable hardtop warning alarm	Sound frequency	(Hz) 1,900	
	Sound cycle	Operation start sound	 ON OFF t : approx. 0.25 s
		Operation complete sound	 ON OFF t : approx. 1 s
		Operation reject sound	 ON OFF t : approx. 0.1 s
		Warning	 ON OFF t 1 : approx. 0.12 s t 2 : approx. 0.06 s

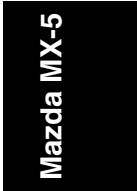

**POWER RETRACTABLE HARDTOP WARNING ALARM OUTLINE**

id092200110200

- Alerts the power retractable hardtop system operation according to a signal from the power retractable hardtop control module.

## INSTRUMENTATION/DRIVER INFO.

### POWER RETRACTABLE HARDTOP WARNING ALARM CONSTRUCTION/OPERATION

id092200110300

#### System Wiring Diagram

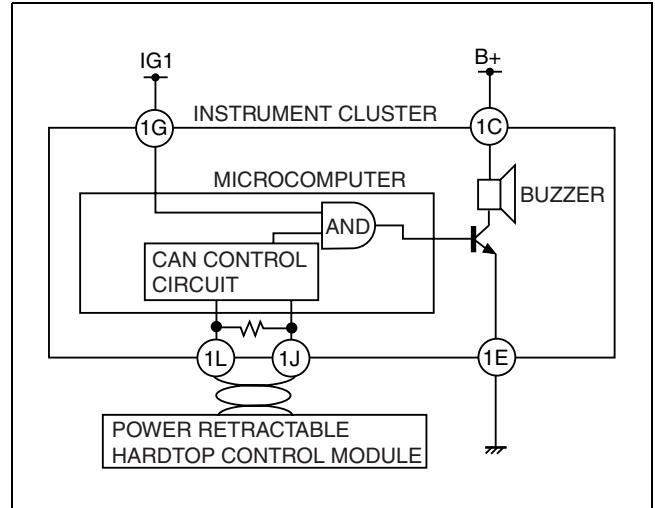

amxuun000003

#### Operation

##### Operation start sound

- A buzzer in the instrument cluster sounds if both of the following two conditions are met:
  - Power retractable hardtop operation conditions are met.
  - The power retractable hardtop (open/close) switch is pressed.

##### Operation complete sound

- A buzzer sounds when the power retractable hardtop open or close operation is completed.

##### Operation reject sound

- A buzzer in the instrument cluster sounds if any of the following conditions are met:
  - The power retractable hardtop operation conditions are not met when the power retractable hardtop (open/close) switch is pressed.
  - The power retractable hardtop (open/close) switch is pressed with the power retractable hardtop system DTC detected.
  - The power retractable hardtop (open/close) switch is pressed when the power retractable hardtop is fully closed and the system DTC is stored.
  - Power retractable hardtop operation conditions are not met during power retractable hardtop operation.
  - An power retractable hardtop system DTC is detected during power retractable hardtop operation.

#### Warning

- A buzzer in the instrument cluster sounds if any of the following conditions are met with the power retractable hardtop half open.
  - Vehicle speed signal is input.
  - The selector lever is in any position except P or N (AT vehicles).
  - The selector lever is not in neutral (neutral switch normal condition) (MT vehicles).

# 09-40 CONTROL SYSTEM

**CONTROLLER AREA NETWORK (CAN)**  
**SYSTEM OUTLINE** . . . . . 09-40-1  
**CAN SYSTEM**  
**STRUCTURAL VIEW** . . . . . 09-40-1

**CAN SYSTEM WIRING DIAGRAM** . . . . .09-40-2  
**CAN SYSTEM DESCRIPTION** . . . . .09-40-2  
 CAN Signal-Chart . . . . .09-40-2  
 On-Board Diagnostic Function . . . . .09-40-3

## CONTROLLER AREA NETWORK (CAN) SYSTEM OUTLINE

id094000101300

- Due to the adoption of the power retractable hardtop control module, the CAN system has been changed.
- Twisted-pair wiring is used for connections between the following modules. (Each electrical module hereafter referred to as a CAN system-related module):
  - PCM
  - TCM (AT)
  - DSC HU/CM (with DSC)
  - ABS HU/CM (with ABS)
  - Keyless control module (with advanced keyless system)
  - Steering angle sensor (with DSC)
  - Instrument cluster
  - Power retractable hardtop control module (with power retractable hardtop)
- With an on-board diagnostic function included for each multiplex module, display of DTCs using the Mazda Modular Diagnostic System (M-MDS) has improved serviceability.

## CAN SYSTEM STRUCTURAL VIEW

id094000101100

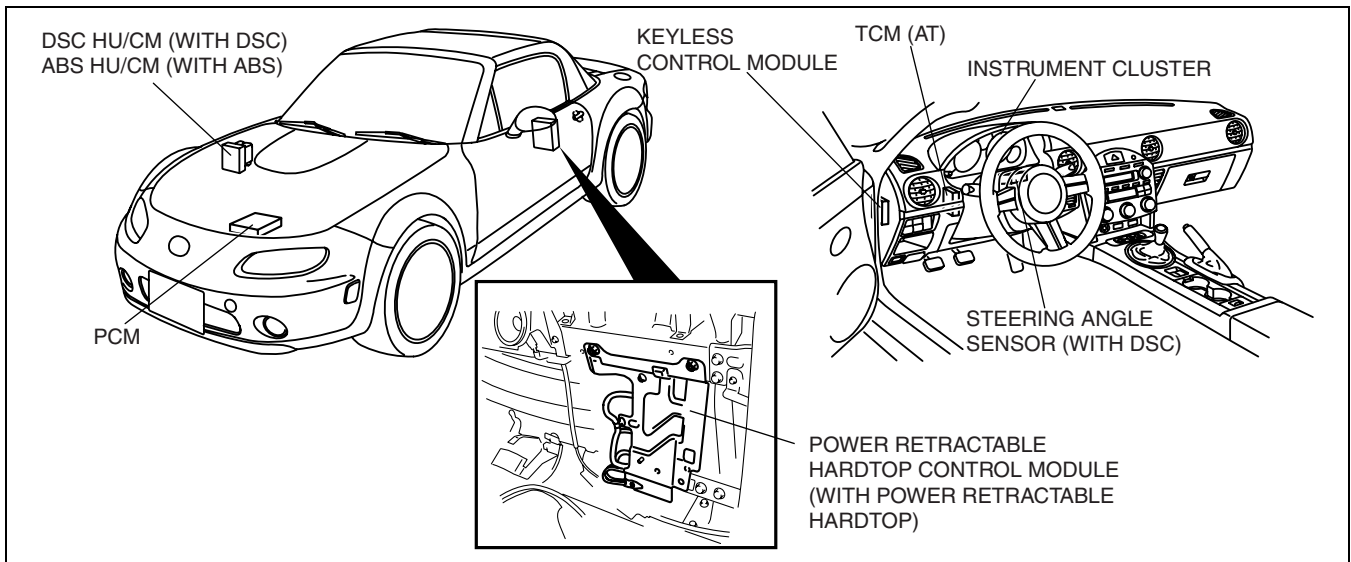

amxuun000000

Mazda MX-5

# CONTROL SYSTEM

## CAN SYSTEM WIRING DIAGRAM

id094000101200

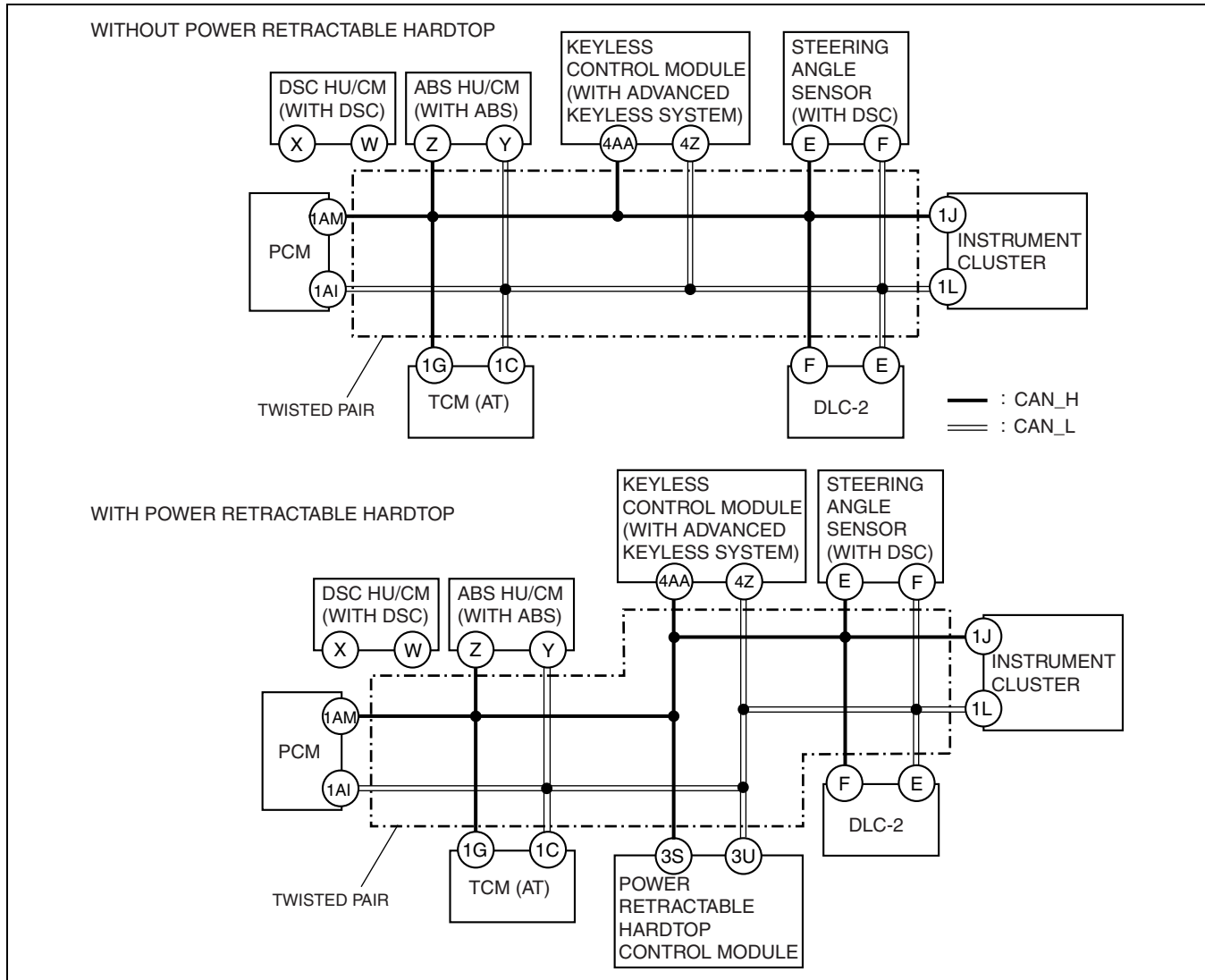

amxuun000000

## CAN SYSTEM DESCRIPTION

id094000101000

### CAN Signal-Chart

OUT: Output (sends signal)  
 IN: Input (receives signal)

Signal	Multiplex module						
	PCM	TCM	ABS HU/CM or DSC HU/CM	Keyless control module	Steering angle sensor	Instrument cluster	Power retractable hardtop control module
Engine speed	OUT	IN	IN (DSC)	IN	—	IN	—
Vehicle speed	OUT	—	—	IN	—	IN	IN
	IN	OUT		—		—	
Engine coolant temperature	OUT	IN	—	—	—	IN	—
Engine torque	OUT	IN	IN (DSC)	—	—	—	—
Accelerator pedal position	OUT	IN	IN (DSC)	—	—	—	—
TP	OUT	IN	IN (DSC)	—	—	—	—
Intake air temperature	OUT	IN	—	—	—	—	—
Ignition timing	OUT	IN	—	—	—	—	—
Engine specification	OUT	—	IN	—	—	—	—

## CONTROL SYSTEM

Signal	Multiplex module						
	PCM	TCM	ABS HU/ CM or DSC HU/CM	Keyless control module	Steering angle sensor	Instrument cluster	Power retractable hardtop control module
Brake pedal position	OUT	IN	–	–	–	–	–
Tire circumference (front/rear)	OUT	IN	IN	–	–	–	–
	IN	–	OUT				
Immobilizer-related information	OUT	–	–	–	–	IN	–
	IN					OUT	
Travelled distance	OUT	–	–	–	–	IN	–
	IN	OUT				IN	
Fuel injection amount	OUT	–	–	–	–	IN	–
MIL on request	OUT	–	–	–	–	IN	–
	–	OUT					
Generator warning light on request	OUT	–	–	–	–	IN	–
Cruise main/set indicator light on request	OUT	–	–	–	–	IN	–
Transmission type	OUT	–	IN	–	–	–	IN
AT gear position/selector lever position (AT)	IN	OUT	–	–	–	IN	IN
Neutral switch status (MT)	OUT	–	–	–	–	–	IN
ATF temperature (AT)	IN	OUT	–	–	–	–	–
Desired gear position (AT)	IN	OUT	IN (DSC)	–	–	–	–
TCC status (AT)	IN	OUT	IN (DSC)	–	–	–	–
AT warning light on request (AT)	IN	OUT	–	–	–	IN	–
Brake system status (EBD/ ABS/DSC)	IN	–	OUT	–	–	–	–
Wheel speed (LF, RF, LR, RR)	IN	–	OUT	–	–	–	–
Brake system warning light on request	–	–	OUT	–	–	IN	–
ABS warning light on request	–	–	OUT	–	–	IN	–
DSC indicator light on request	–	–	OUT (DSC)	–	–	IN	–
DSC OFF light on request	–	–	OUT (DSC)	–	–	IN	–
Security light on request	–	–	–	OUT	–	IN	–
Steering angle sensor status	–	–	IN (DSC)	–	OUT	–	–
Fuel tank level	IN	–	–	–	–	OUT	–
Parking brake position	–	–	IN (DSC)	–	–	OUT	–
Power retractable hardtop warning alarm request	–	–	–	–	–	IN	OUT
Power retractable hardtop information	–	–	–	IN	–	–	OUT
Trunk lid operation	–	–	–	IN	–	–	OUT
Deck panel limit switch (close switch) status	–	–	–	IN	–	–	OUT

### On-Board Diagnostic Function

- Some DTCs have been changed.
- The on-board diagnostic function is incorporated into the following module:
  - PCM
  - TCM (AT)
  - DSC HU/CM (with DSC)
  - ABS HU/CM (with ABS)
  - Keyless control module
  - Steering angle sensor (with DSC)
  - Instrument cluster
  - Power retractable hardtop control module (with power retractable hardtop)
- Using the Mazda Modular Diagnostic System (M-MDS), DTCs can be read out and deleted.

# CONTROL SYSTEM

## Block diagram

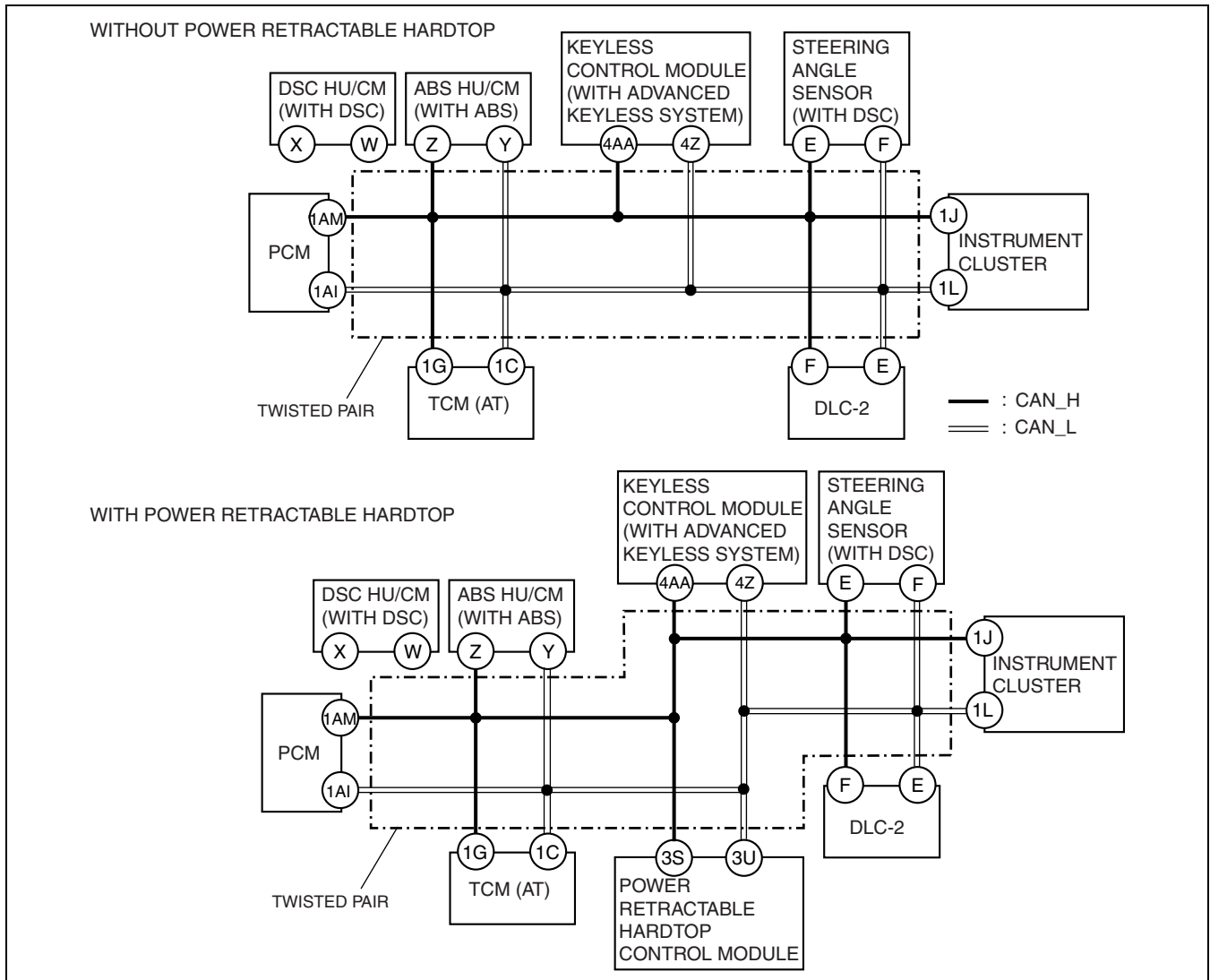

amxuun000000

## CONTROL SYSTEM

### Self-malfunction diagnostic function

- The self-malfunction diagnostic function determines that there is a malfunction, and outputs a signal, as a DTC, to the DLC-2. The DTC can be read out using the Mazda Modular Diagnostic System (M-MDS).

### DTC table

DTC	Malfunction location	DTC output module
U0073	CAN system communication error	<ul style="list-style-type: none"> <li>PCM</li> <li>TCM</li> <li>DSC HU/CM</li> <li>ABS HU/CM</li> <li>Power retractable hardtop control module</li> <li>Keyless control module</li> <li>Instrument cluster</li> </ul>
U0100	Communication error to PCM	<ul style="list-style-type: none"> <li>TCM</li> <li>DSC HU/CM</li> <li>Power retractable hardtop control module</li> <li>Keyless control module</li> <li>Instrument cluster</li> </ul>
U0101	Communication error to TCM	<ul style="list-style-type: none"> <li>PCM</li> <li>DSC HU/CM</li> <li>Power retractable hardtop control module</li> <li>Instrument cluster</li> </ul>
U0121	Communication error to DSC HU/CM or ABS HU/CM	<ul style="list-style-type: none"> <li>PCM</li> <li>Instrument cluster</li> </ul>
U0155	Communication error to instrument cluster	<ul style="list-style-type: none"> <li>PCM</li> <li>DSC HU/CM</li> </ul>
U0207	Abnormal message from power retractable hardtop control module	Keyless control module
U0214	Communication error to keyless control module	Instrument cluster
U0323	Communication error to instrument cluster	Keyless control module
U1900	Communication error to other module	<ul style="list-style-type: none"> <li>DSC HU/CM</li> <li>ABS HU/CM</li> <li>Steering angle sensor</li> </ul>
U2023	Abnormal message from PCM	<ul style="list-style-type: none"> <li>DSC HU/CM</li> <li>ABS HU/CM</li> <li>Keyless control module</li> </ul>
U2197	Invalid vehicle speed signal data	Power retractable hardtop control module
U2516	CAN system communication error	<ul style="list-style-type: none"> <li>Instrument cluster</li> <li>Information display</li> </ul>

