

<b>Subject:</b>  WATER LEAK ABOVE SIDE WINDOWS	<b>Bulletin No:</b> 09-036/06
	<b>Last Issued:</b> 9/1/2006

## APPLICABLE MODEL(S)/VINS

2006 MX-5 vehicles with VINs lower than JM1 NC\*\*\*\* \*\* 111535 (produced before December 27, 2005)

## DESCRIPTION

Some vehicles may experience water leaks into the vehicle cabin from under the weather-strip above the side windows. As a mass production change, the sealing of the soft top cloth at the weather-strip retainer has been improved.

### NOTE:

- The water leak addressed in this bulletin is between the weather-strip retainer and the soft top, NOT between the weather-strip and the window.

Customers having this concern should have their vehicle repaired using the following repair procedure.

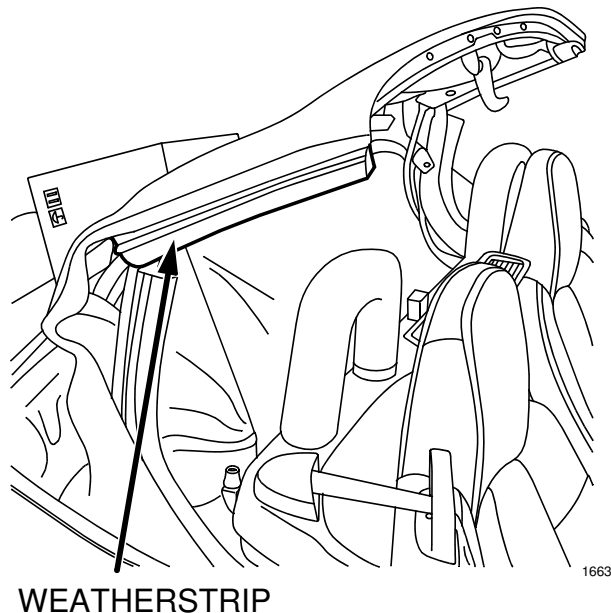

## REPAIR PROCEDURE

1. Verify customer concern.
2. Open the soft top partially.
3. Place a clean, fully formed and closed cardboard box behind the soft top (in the rear window area) as shown.

### NOTE:

- Using a cardboard box or equivalent to keep the soft top in the half-open position will allow this procedure to be performed by a single (1) technician.

PLACING A FULLY FORMED  
AND CLOSED CARDBOARD  
BOX BEHIND SOFT TOP  
AS SHOWN WILL  
PREVENT TOP FROM  
OPENING COMPLETELY

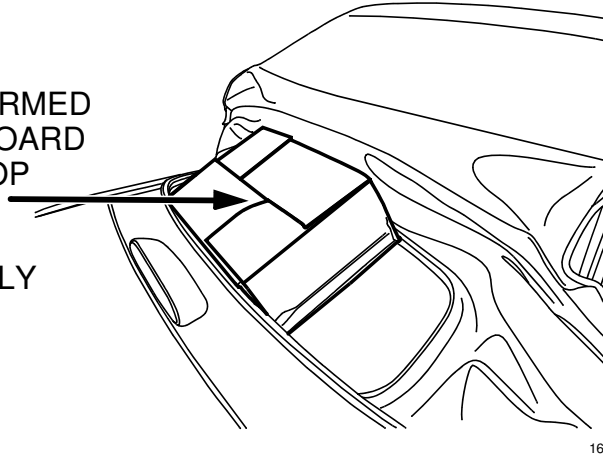

16E

4. Open the soft top to rest on the cardboard box in the half-way open position.
5. Remove the front-side weather-strip by removing two screws at the front and one fastener in the rear.

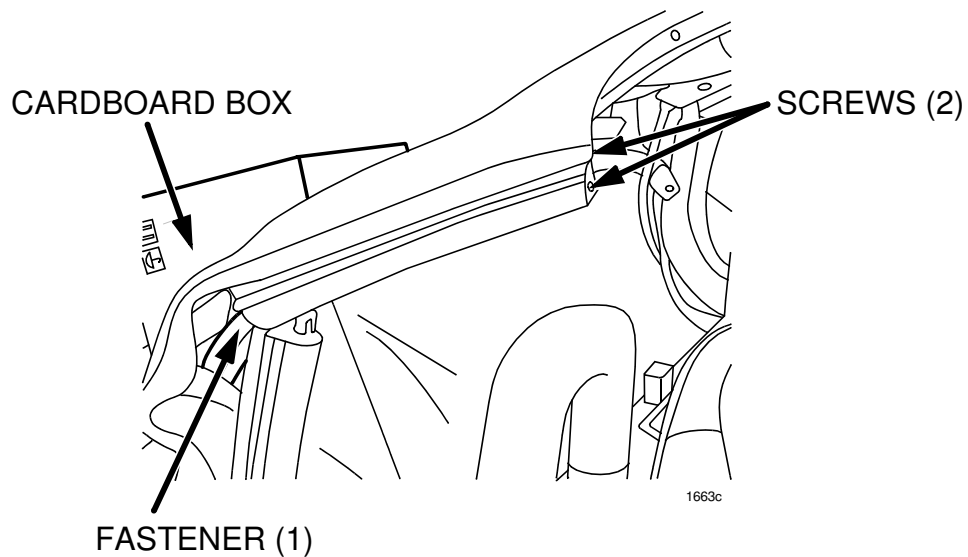

1663c

6. Remove the retainer by removing the three screws.

**NOTE:**

- Before removing the retainer, place positioning marks on the screws and retainer as shown for proper alignment during installation.

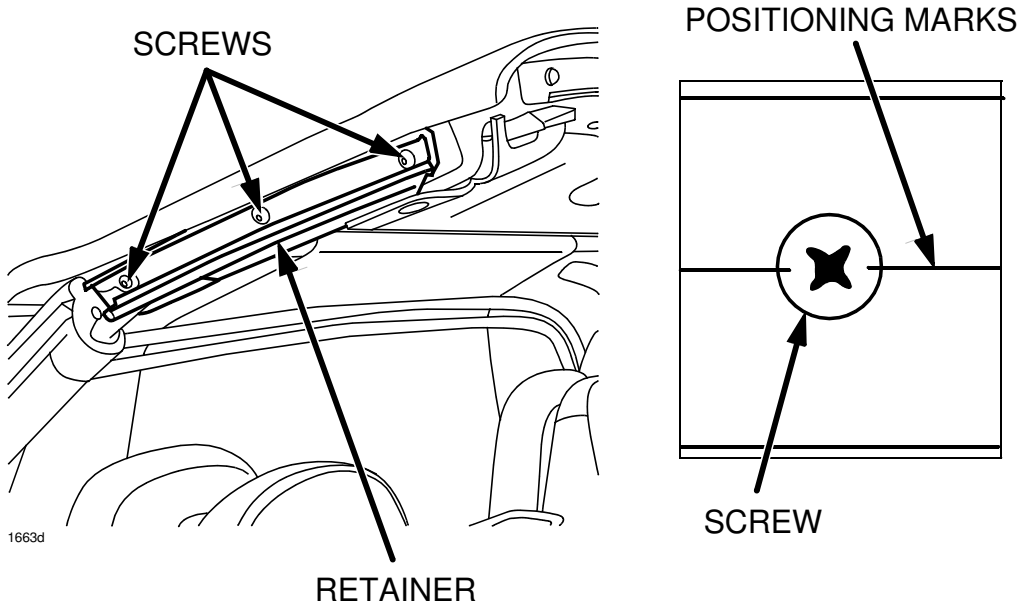

7. Peel back the top cloth from the frame and affix a foam pad to the retainer flange as shown.

**NOTE:**

- Before attaching the foam pad, clean the surface of any contamination that will prevent proper adhesion.

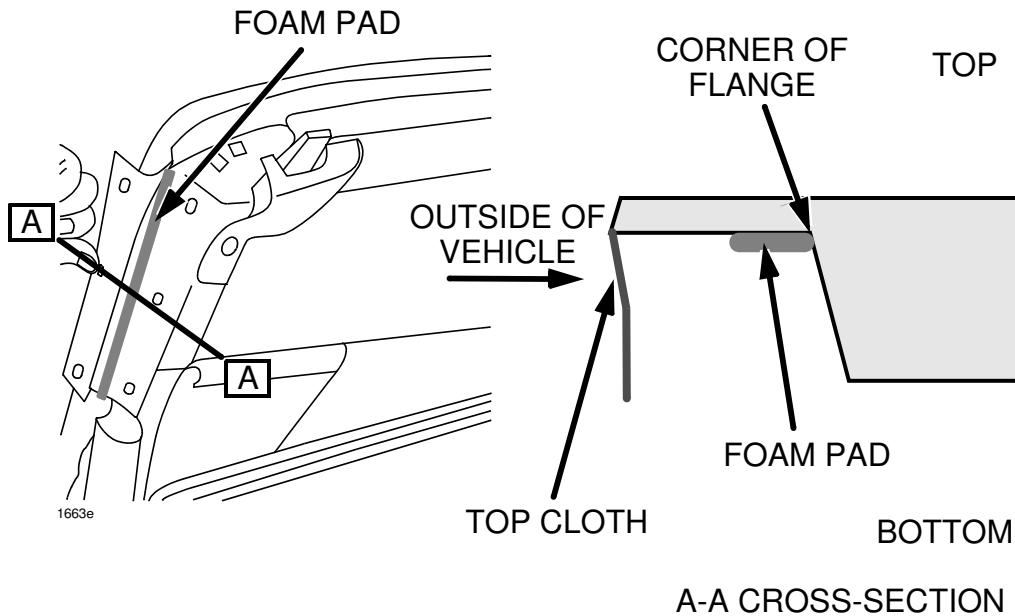

8. Fold the top cloth down over the top frame and reinstall the retainer.

**NOTE:**

- Ensure the positioning marks are aligned when installing the retainer. Failure to do so may result in the possibility of water leakage from the joint between the weather-strip, window glass and weather-strip.

9. Reinstall the front side weather-strip.

**NOTE:**

- Ensure the edge of top cloth is rolled in and is not exposed outside.

10. Verify repair.

## PART(S) INFORMATION

Part Number	Description	Qty.	Notes
NEY1-R1-221	Foam Pad	1	One side: 1 pc, Both sides: 2 pcs Size: 3 mm x 8 mm x 275 mm

## WARRANTY INFORMATION

**NOTE:**

- This warranty information applies only to verified customer complaints on vehicles eligible for warranty repair. Refer to the Warranty Wizard for warranty term information.
- Additional diagnostic time cannot be claimed for this repair.

Warranty Type	A
Symptom Code	77
Damage Code	97
Part Number Main Cause	NEY1-R1-221
Quantity	1 or 2
Operation Number / Labor Hours:	XXB361R1 / 0.3 Hrs (One side) XXB361R2 / 0.5 Hrs (Both sides)