

MAZDASPEED

PERFORMANCE ACCESSORIES

INSTALLATION INSTRUCTIONS

Please check for compliance with local law prior to purchase and installation of this device.

PART NUMBER:
GRMS-8M-D30A
CARB #: D-607

INTAKE SYSTEM

APPLICABLE MODELS:
2006-08 Mazda MX-5 2.0L 4cyl.
(All Models)

CONTENTS

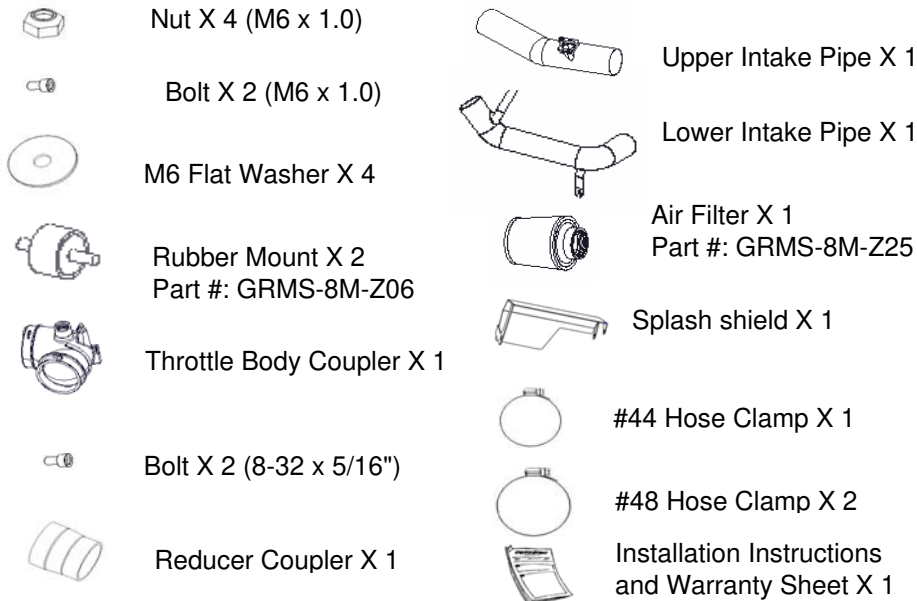

TOOLS REQUIRED

8,10,& 12mm Sockets
Ratchet
6" & 11" Extension
Phillips Head / Flat Head
Screwdriver Set
10mm Wrench
3.5mm Allen Wrench
Safety Glasses

Note: Mazdaspeed Accessories carry a different warranty than Genuine Mazda Accessories. Review the applicable warranty statement with your Mazdaspeed dealer. This product is sold under the Mazdaspeed Green Warranty Statement.

0 PRE INSTALLATION

1. Read entire instruction sheet before proceeding.
2. Run OBD II diagnostics and repair or replace any malfunctioning components before installation.
3. Make sure vehicle is parked on a level surface and set the parking brake.
4. Disconnect both battery terminals.
5. If engine has run within the past two hours let it cool down.
6. Chock the rear wheels, and use properly rated jack stands when lifting the vehicle
7. Wear eye protection.

1 STOCK INTAKE REMOVAL

1. Remove both front wheels from the car.
2. Unclip the hard plastic breather hose from the breather nipple by squeezing the blue retaining clip.
3. Lift up and remove the steel bracket securing the purge solenoid valve (PSV) to the inlet hose. Leave the PSV attached to the valve and move it out of the way.
4. Unplug the MAF sensor from the wiring harness.
5. Unclip the MAF sensor wiring harness from the side of the air filter housing
6. Loosen the hose clamps securing the inlet hose to the throttle body and the air filter housing. Remove the inlet tube.(View B, #5)
7. Remove the air filter housing lid (View B, #1) by unhooking the metal retaining clips and sliding the lid out.
8. Remove the air filter element (View B, #2).
9. Remove the lower air filter housing (View B, #3) by removing the two nuts securing the housing to the chassis. Next, lift up on the back side of the housing and remove it from the vehicle.

View A: Breather Hose and PSV Removal

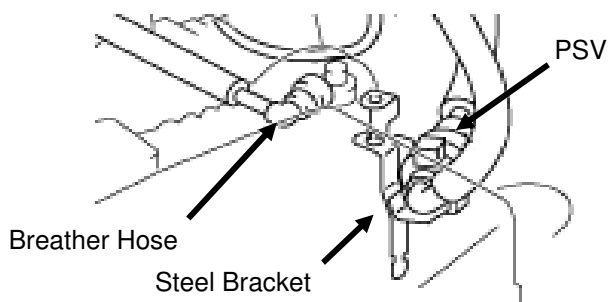

Continued on page 2

1

STOCK INTAKE REMOVAL (CONTINUED)

View B: Stock Air Filter Housing Exploded

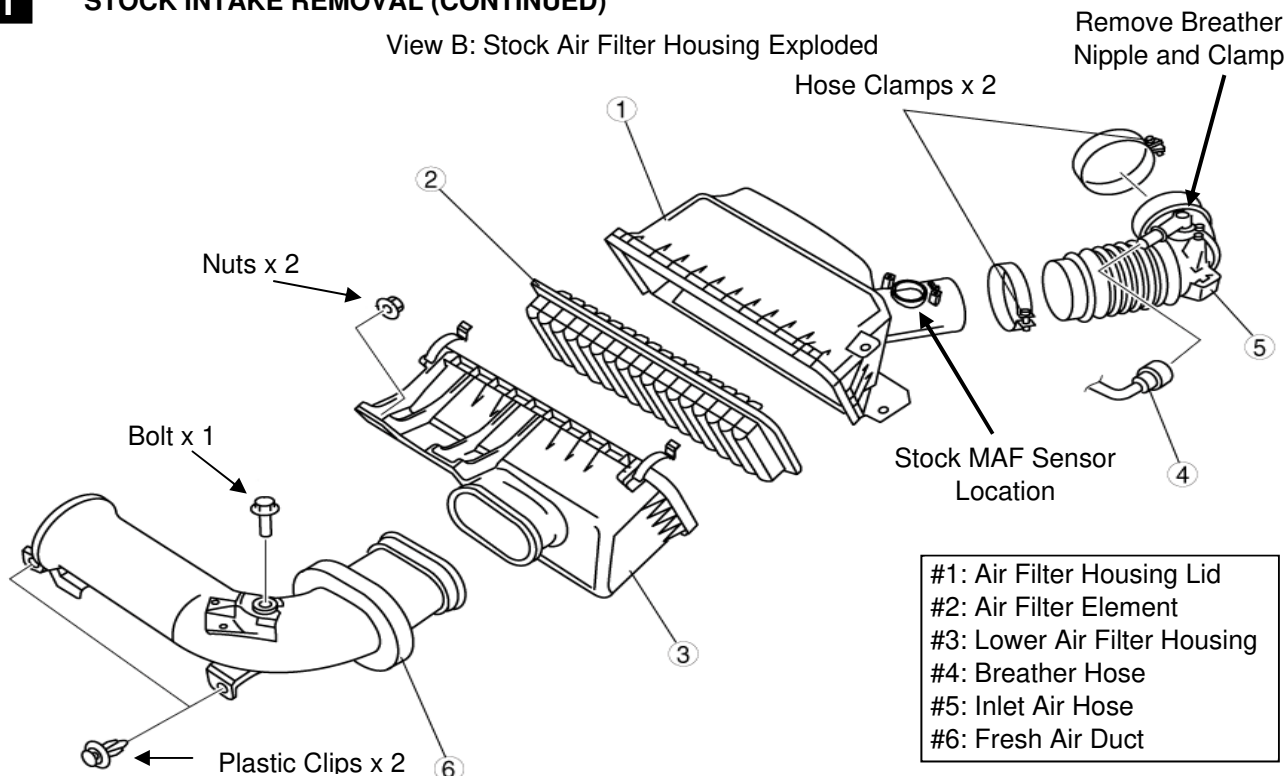

- #1: Air Filter Housing Lid
- #2: Air Filter Element
- #3: Lower Air Filter Housing
- #4: Breather Hose
- #5: Inlet Air Hose
- #6: Fresh Air Duct

10. Remove the retaining clips and bolts securing the driver and passenger side splash shields to the bumper and chassis. Remove the splash shields.
11. Disconnect the front fog light connectors for vehicles equipped with fog lights.
12. Disconnect the side marker light connectors.
13. Remove the parts in the order indicated in Table A:

Table A for View C: Bumper	
1	Screw A
2	Plastic Fastener A
3	Plastic Covers
4	Bolt A
5	Nut
6	Bolt B
7	Bolt C
8	Front Bumper

View C: Bumper Removal / Installation

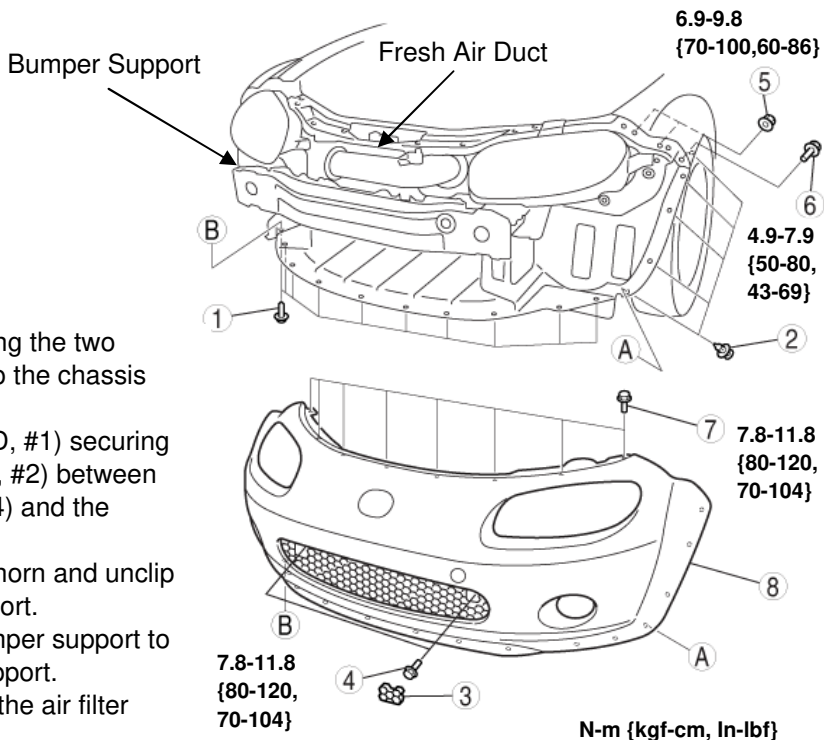

14. Remove the fresh air duct by removing the two plastic clips and the bolt securing it to the chassis (View B, #6).
15. Remove the plastic fasteners (View D, #1) securing the plastic shroud seal plate (View D, #2) between the steel bumper support (View D, #4) and the chassis.
16. Unhook the wiring harness from the horn and unclip it (View D, #3) from the bumper support.
17. Remove the 8 bolts securing the bumper support to the chassis. Remove the bumper support.
18. Remove the stock MAF sensor from the air filter housing lid (View B, #1).
19. Remove the plastic breather nipple, spring clamp, and two hose clamps from the stock inlet hose.

Continued on page 3

1 Stock Intake Removal (Continued)

View D: Steel Bumper Support

- #1 Plastic Clips
- #2 Shroud Seal Plate
- #3 Harness Clip
- #4 Steel Bumper Support

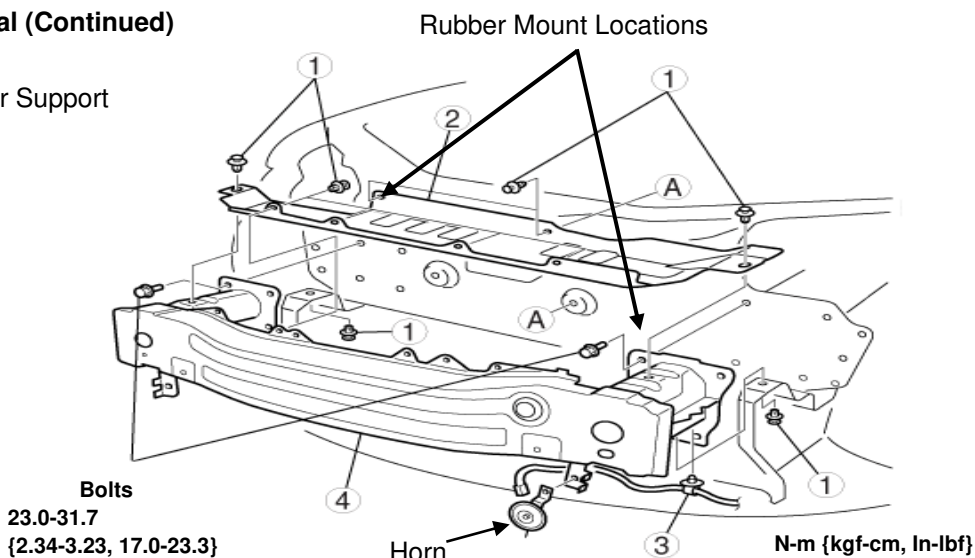

2 INSTALLATION OF MAZDASPEED INTAKE

1. Install the plastic breather hose nipple (View E, #2) removed in step 1-19 into the supplied throttle body coupler (View E, #3) and secure using the stock spring clamp (See View F).
2. Install the two hose clamps removed in step 1-19 (View B) onto the supplied throttle body coupler. Install the coupler onto the throttle body. Do not tighten hose clamp.
3. Install the steel PSV bracket (View E, #1) from the stock inlet tube by sliding it into the mount on the throttle body coupler. Be sure bracket is fully seated at top guide pin.
4. Plug the plastic breather hose onto the nipple. Be sure both the breather hose and PSV bracket are secure before proceeding.
5. Install the MAF sensor into the upper intake pipe (View E, #4) and secure using the two supplied 8-32 bolts (View E, #5). Torque the bolts to 12-15 in-lbs (1.4-1.7 N-m).
6. Install the upper pipe into the throttle body coupler on the throttle body using the stock hose clamp. Do not tighten. NOTE: MAF sensor position forward of elbow when in position.
7. Install the reducing coupler (View E, #8) onto the opposite end of the upper pipe using the supplied #44 hose clamp (View E, #6). Do not tighten.
8. Install the two rubber mounts (View E, #12) into the front of the chassis where the steel bumper support was removed (See View D). Use the supplied washers and 6mm nuts to secure (View E, # 10 & 11).
9. Install the lower intake pipe (View E, #9) into the reducing coupler on the upper intake pipe and align the pipe brackets with the corresponding holes. Once aligned, attach the pipe using a #48 hose clamp (View E, #7). Do not tighten.
10. Install the supplied rubber mounts into the holes where the pipe brackets align. Secure the pipe brackets to the rubber mounts using the supplied washers and 6mm nuts (View E, #10 & 11). Torque the nuts to 23-30 in-lbs (2.5-3.4 N-m).
11. Position upper pipe to lower pipe and couplers as required for best fit. Torque all hose clamps to the correct torque specifications.
12. Position #48 hose clamp (View E, #7) onto filter at six o'clock with hex head facing front of vehicle when installed. Install the filter on to the end of the lower intake pipe. Push the filter over the pipe until the stop in the filter is reached and torque hose clamp to specification.
13. Mount splash shield (View E, #14) to the filter (View E, #13) and lower intake pipe (View E # 9) by inserting the nub on top of filter through the center hole on the splash shield brace. Then secure the upper portion of the splash shield to the lower intake pipe using the two supplied M6 bolts.
14. Connect the MAF sensor connector from the wiring harness into the sensor mounted on upper pipe.
15. Reinstall the steel bumper support using the 8 previously removed bolts (See View D). Note: the shroud seal plate will not be reused. Check that the filter is not touching any part of the vehicle.
16. Reinstall the bumper by repeating the steps in Table A starting at step 8 and working up to step 1.
17. Plug in the fog lights (if equipped) and side marker light connectors.
18. Reinstall the plastic splash shields to the chassis and the bumper.

2 INSTALLATION OF MAZDASPEED INTAKE (CONTINUED)

- #1: PSV Bracket
- #2: Breather Nipple
- #3: Throttle Body Coupler
- #4: Upper Intake Pipe
- #5: 8-32 MAF Sensor Bolts
- #6: #44 Hose Clamp
- #7: #48 Hose Clamp
- #8: Reducing Coupler
- #9: Lower Intake Pipe
- #10: Rubber Mount
- #11: 6mm Flat Washer
- #12: 6mm Nut
- #13: Air Filter
- #14: Splash Shield

View F: Throttle Body Coupler Assembly

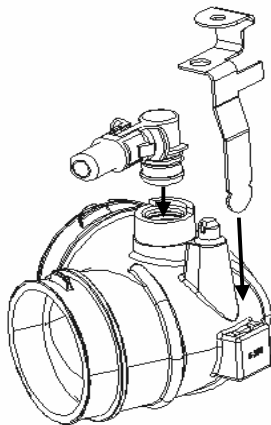

VIEW E

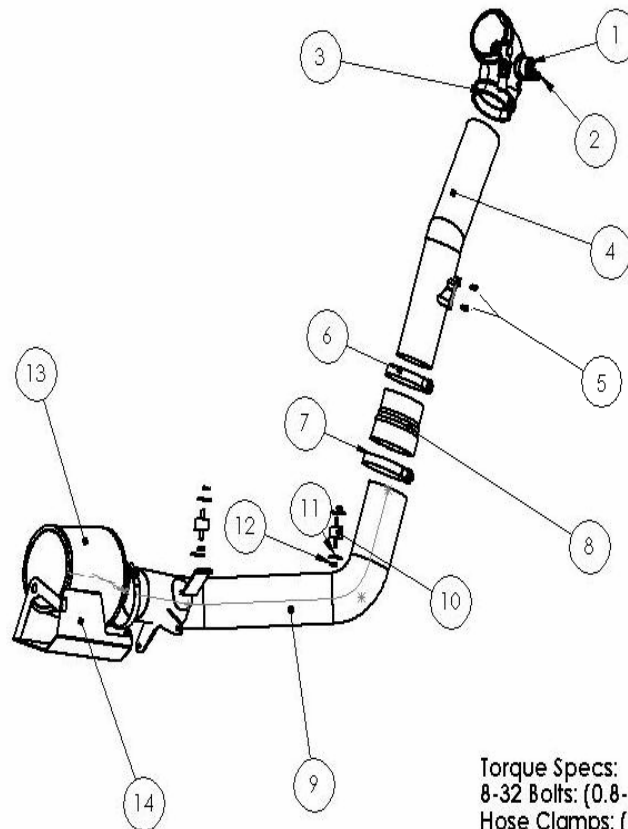

Torque Specs:
8-32 Bolts: (0.8-1.2 N·m, 7.1-10.6 in-lbs)
Hose Clamps: (3-6 N·m, 26.6-53.1 in-lbs)
M8 Nut: (7-10.5 N·m, 62.0-92.9 in-lbs)
M6 Nut: (6-9 N·m, 53.1-79.7 in-lbs)

Note: Applicable torque values provided in illustrations.

3 POST INSTALLATION INSPECTION / CLEAN-UP

1. Inspect all connection points.
 - Two rubber mounts
 - MAF sensor harness
 - Throttle body coupler including breather hose and PSV mount
2. Inspect the engine bay for any loose tools and check that all fasteners that were moved or removed are properly tightened, including the wheel and fender liner. Start engine and perform a final inspection before driving the vehicle.
3. Wipe finger prints off of the intake pipe with soft cloth.
4. Return original intake and installation instructions to customer.
5. **Note: Clean your filter every 20,000 miles per the instructions on the included filter cleaning kit.**
6. **Caution: If you anticipate traversing deep water, remove this system and replace it with the original equipment intake system. All warranties are null and void if water is ingested into the intake system.**
7. **Caution: Modification, tampering or removal of any undercarriage or wheel housing mudguard will void all powertrain warranties.**