

MAZDASPEED

PERFORMANCE ACCESSORIES

INSTALLATION INSTRUCTIONS

Part Number
RAMS-8M-D12

MAZDASPEED BY BREMBO BIG BRAKE KIT

Applicable Models
2006> MX-5 (North American Models Only)

Contents of Kit



Installation Instructions
& Warranty Statement



1 Right and 1 Left Caliper
(Mirror Designs) Includes Brake Pads
and Mounting Brackets

Service Parts For Caliper Assembly
Brake Pad Kit: RAMS-8M-D15
Calipers w/Brackets: RAMS-8M-D18

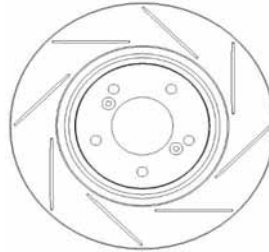

1 Right and 1 Left 310mm Slotted Discs
Service (set): RAMS-8M-D16



2 Braided Brake Hose Assemblies
Service: RAMS-8M-D17



1 Right and 1 Left Mid-Line Bracket
(Stamped "R" and "L")

Tools Required



Wrenches, including flare nut wrench
(Mazda SST 49 0259 770B)



Torque wrench



Pliers



Screwdriver (possibly an impact screw driver)



Spacer (Brake Pedal Depressor Tool)



Piston retractor
(Mazda SST 49 0221 600C)



Dial indicator with magnetic base



Brake fluid collection tank.



Brake system bleeder tool(s)



Jack and jack stands



Clean cloth.



Solvent for cleaning



Vehicle service manual

0 Pre-Installation

• **WARNING!** Stock wheels will NOT fit. For proper fit and function, you must complete the wheel/tire package study prior to installation. Proper removal and installation of brake components is critical to the safety and reliability of any vehicle. Therefore, brake components should only be installed and serviced by a qualified licensed mechanic experienced in the installation and removal of brake components. Lack of compliance with any of these requirements can cause serious harm or death.

• Mazdaspeed Accessories carry a different warranty than Mazda Genuine Accessories. Review the applicable warranty statement with your Mazdaspeed dealer. The Big Brake Kit is sold under the Mazdaspeed Orange Warranty Statement.

- Read complete instructions before starting the installation of the Mazdaspeed by Brembo Big Brake Kit.
- The Big Brake Kit is approved for North American vehicles only.
- Use a torque wrench on each bolt during installation. Torques are listed for each fastener.
- Provide instructions and OE take-off parts to the end user. Store instructions in a safe place for future use.
- Take care not to get any brake fluid on painted surfaces of the vehicle. Brake fluid can damage paint.

CAUTION: Wheel Spacers are dangerous as the wheel may no longer be supported by the hub-pilot and may lack the structure required by Mazda's engineering specifications. Wheel spacers should never be used on any Mazda vehicles.

CAUTION: Wheel and tire combination that extend the tire and/or wheel beyond the OEM fender should never be used on any Mazda vehicle as vehicle driving dynamics and component forces could exceed design specification limits. Only wheels and tires with specifications meeting Mazda engineering specifications and DOT requirements should be used.

CAUTION: The brake system must be bled properly after installation. Any air in the system can severely impact performance negatively. Only new brake fluid that meets Mazda's specifications should be used. Any contamination or compatibility issues can also impact performance negatively.

CAUTION: The brake system must be burnished properly after installation or performance can be impacted negatively.

CAUTION: Never use sealant on brake line fittings.

IMPORTANT: High performance brakes may exhibit differences in braking attributes than that of factory-equipped vehicles, including more stopping power per the same brake pedal pressure input as well as increased noise and dust. Only persons familiar with the specific handling and braking characteristics of this vehicle should be allowed to drive when they are confident in their abilities to maintain control, and only in "off road" use.

2 Remove OEM Parts

- 1) Loosen, but do not remove, the bracket that holds the inboard end of the brake hose to the chassis.
- 2) Disconnect the brake tube from the brake hose, then plug the end of the brake tube (you can use the plastic plugs used in the new calipers).
- 3) Allow the end of the brake hose to drain into a pan, or plug the end.
- 4) Finish removing the brake hose bracket at the chassis, and remove the brake hose bracket on the control arm (Mid-Line Bracket). Retain both bolts for installation of the new brake line. (Mid line and chassis bracket bolt are common).
- 5) Remove the caliper assembly. Take care to support the caliper when the second bolt is removed to prevent damage or injury due to the heavy weight. Retain these bolts for installation of the new caliper.

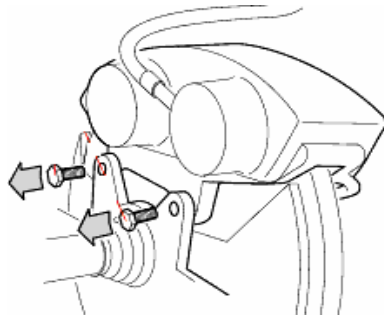

- 6) Find the correct caliper and rotor for each side of the vehicle. Make sure the caliper bleeders will be pointing up when installed. Refer to the image below for disc orientation. (Driver side shown)

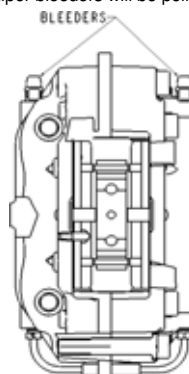
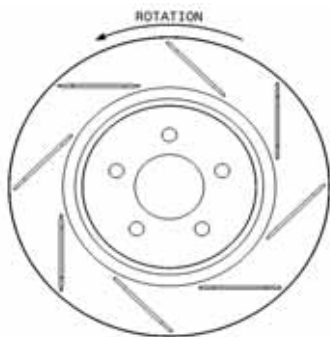

- 7) Remove the rotor screws. A hammer-impact tool may be necessary to loosen the screws. Take care not to strip the screw heads.
- 8) Remove the rotor from the wheel hub.
- 9) Clean all mounting surfaces for the disc and caliper.

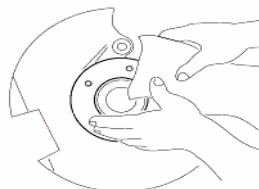

- 10) Carefully trim the heat shielding along two sections indicated in the picture below.
- 11) Check clearance with the rotor placed against the wheel hub firmly. If required: carefully bend the air deflector ear inboard to avoid any interference.

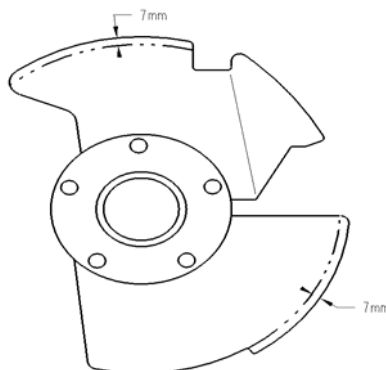

Note: Do NOT completely remove the heat shield. If there is any contact after installing the Brembo Disc, carefully bend in the area where contact occurs and repeat clearance check.

3 Disk Run out Check

It is recommended that the disc lateral run out measurements be performed upon installation of the new disc. This is to ensure that the vehicle hub & bearing is in perfect working order and in the correct phase with the new disc. If a vibration problem should be present, and this procedure was not followed due to lack of availability of the proper tools and equipment, take the vehicle to a facility capable of performing run out measurements.

1) Place the correct disc onto the hub. When the disc is rotated in the forward direction, the leading edge of the slots should be towards the OD of the disc (refer to the image below).

2) Temporarily install all of the wheel bolts using several washers on each stud to prevent damage to the disc, and to prevent the nuts from bottoming before securely clamping the disc to the hub. Torque nuts to 20Nm.

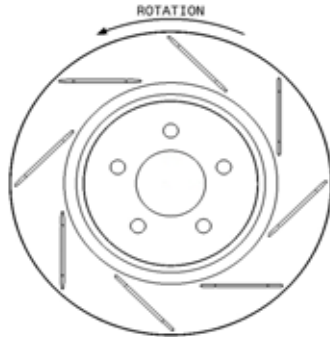

Note: The new rotor does not require the mounting screws used on the original rotor (removed in Section 2, Step 7).

3) Place the magnetic base for the Indicator solidly on the vehicle ensuring that it will not move during the measurement procedure. Place the Indicator needle on the outboard braking surface of the disc approximately 3-5mm from the outer edge of the disc ensuring that the slots on the disc will not contact the indicator when the disc is rotated.

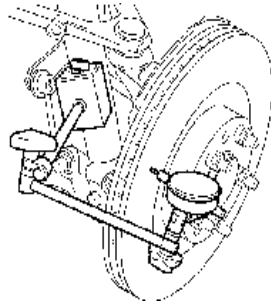

4) Turn the disc through a full revolution. The T.I.R. (Total Indicator Reading) should not exceed 0.07mm (.003"). If the disc run out exceeds this value, it may be possible to reduce it by removing and rotating the disc to a different orientation on the lugs.

5) If the run out still exceeds the above value, the vehicle hub and/or wheel bearing is most likely out of specification. Consult the vehicle manufacturer's service manual for the steps needed to correct this condition.

6) Repeat disc run out check for the opposite side of the vehicle.

4 Install Brembo Parts

- 1) Re-verify that you have the correct caliper (bleeders point up). Verify the preassembled brake pads are installed snug to the caliper. Verify the mounting bracket is installed to the caliper. (Torque will be validated in step number 4)
- 2) Re-verify the mounting surfaces for the caliper bracket-to-hub interface are clean.
- 3) Slide the new caliper assembly over the disc. Use the bolts that originally secured the OEM caliper to attach the new caliper/bracket assembly to the hub. (Section 2, step 5)
- 4) Torque the 2 mounting bolts to 101 Nm. Validate torque of the 2 pre-assembled caliper-to-bracket bolts to 115 Nm.
- 5) Install the provided mid-line brackets onto the rubber grommets on the brake lines before brake lines are installed. These brackets are marked "L" (driver's side) and "R" (passenger side) to denote the side of the vehicle they are to be used on. In the picture below, the left hand line is on the top, and the right hand line is on the bottom. Referencing this picture for bracket orientation, install the mid-line brackets by inserting the grommet that is on each line through the hole in the mid-line bracket. Ensure that the grommet has been fully seated in the bracket.

Note: Brake lines are the same until the sided mid-line brackets are installed.



- 6) Install the mid-line bracket provided in the kit to the upper control as shown below (Drivers side shown), using the bolt removed originally for the mid-line bracket, section 2 step 4. Torque to 11 Nm for the mid-line bracket bolt.

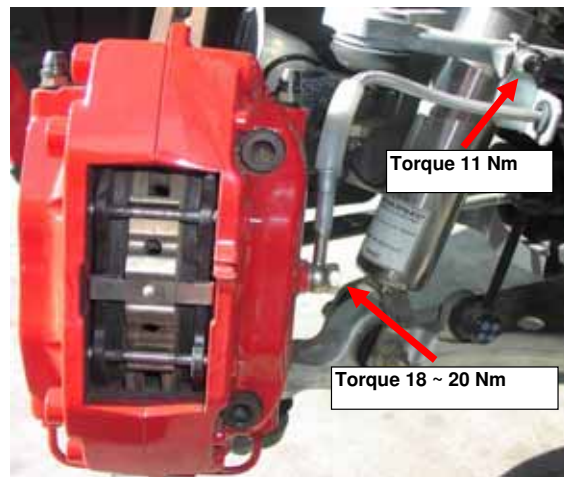
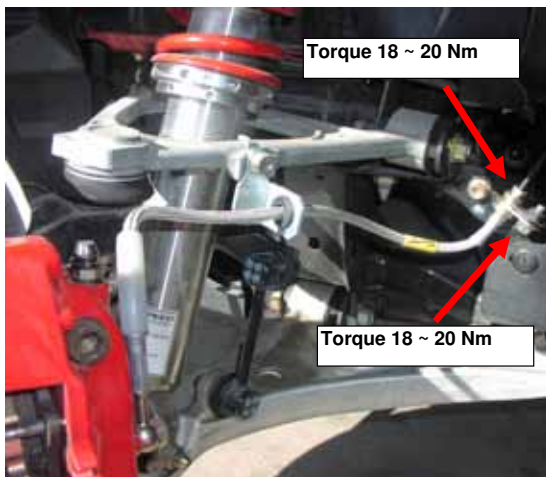

- 7) Attach the chassis end of the brake line using the original bolt (Section 2, step 4). Attach the other end of the brake line to the caliper using the included banjo bolt and 2 copper washers. One washer is placed on each side of the banjo fitting. The brake line should be oriented so that it is pointed up to the caliper bleeder as shown above.
- 8) Confirm proper orientation of the fittings at both end of the brake line. Ensure there is only minimal twisting of the brake line with both ends installed.
- 9) With the brake line oriented as shown above in Step 5, hold the hard tube of the brake line to prevent movement and torque the banjo bolt to 18-20Nm.
- 10) Remove the plug from the end of the chassis brake line and thread the tube nut into the inboard end of the brake hose fitting.
- 11) Torque the bolt that secures the inboard brake hose bracket to the chassis to 18-20Nm.
- 12) Torque the tube nut threaded into to the brake hose to 18-20Nm.
- 13) Inspect the complete installation carefully, then repeat Section 4 for the opposite side of the vehicle.

5 Inspect Clearances

- 1) Carefully install the wheel, making sure not to contact the caliper, and check the following:
 - Brake Line: Should not kink or come within 6mm of any suspension component in straight, right and left steering positions. Check when the suspension is in droop (front end jacked up) and at ride height (on the ground).
 - Wheel: Should not be within 2.5mm of the brake caliper at any point on the wheel at any rotation.

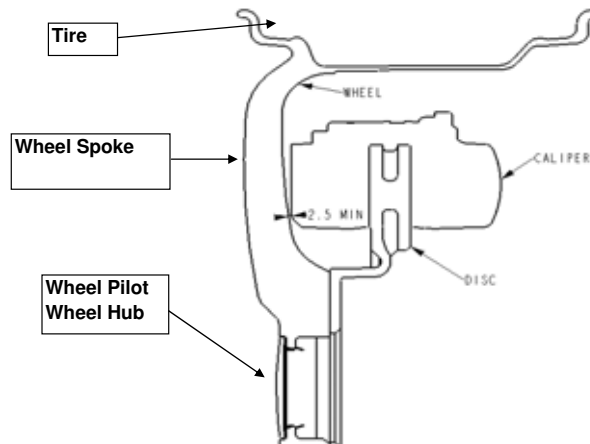

6 System Bleeding

CAUTION: The brake system must be bled properly after installation. Any air in the system can severely and negatively impact performance. Only new brake fluid that meets Mazda's specifications should be used. Any contamination or compatibility issues can also impact performance negatively.

Note: There are 2 bleed screws on each caliper. The bleeding procedure must be performed on all bleed screws that are in the system.

Note: During the bleeding procedure, ensure that the brake fluid reservoir on the master cylinder does not pass the minimum level marked on the reservoir. Keep the fluid level between the min and max levels indicated on the reservoir at all times.

Note: Always refer to the brake bleeding tool's instruction manual.

- 1) Carefully remove the wheel, making sure not to contact the caliper.
- 2) Remove the protective cap from the inboard bleed screw and slide the collection/suction tank hose, or bleed drain hose, over the bleed screw.
- 3) Repeatedly press the brake pedal, then keep the brake pedal pressed either by obtaining the assistance of another person, or by placing brake pedal depressor spacer tool in position as directed in the tool's instruction manual.

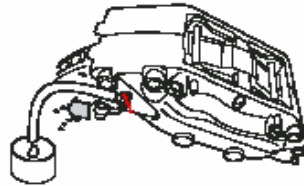

- 4) With pressure applied to the pedal, loosen the bleed screw $\frac{1}{2}$ to $\frac{3}{4}$ of a turn, allowing fluid and air to escape. Re-tighten after air evacuation stops before releasing the brake pedal.
- 5) Repeat steps 6.2 and 6.4 until there is no more air evacuates from the bleeder. Remember to keep the fluid level in the reservoir between between the min and max level.
- 6) Perform steps 6.2 to 6.4 on the outboard bleed screw.
- 7) Repeat steps 6.1 to 6.6 on the other side of the vehicle.
- 8) Torque all 4 bleed screws to 14 Nm.
- 9) Check the brake pedal for firmness. If the pedal feels spongy, repeat steps 6.2 to 6.8.
- 10) Reposition all the protective caps on the bleed screws.
- 11) Verify the reservoir is properly filled to the specified "max" level on the side of the reservoir and install the reservoir cap.
- 12) Clean any fluid that may have escaped off components using soap and water. Clean the brake rotors using brake cleaner by cleaning the half of the rotor that is away from the caliper, then dry. Rotate the disc 180 degrees and clean the other side. Repeat on the other side of the vehicle.
- 13) Start the car and have a 2nd person press the brake pedal hard while you check the system to insure there are no leaks.
- 14) With the engine running, depress the pedal with force of 147N (33.0 lbf) and hold.
- 15) Measure the distance between the pedal pad center and the insulator. Verify the dimension, as shown on the right, is at least 106mm (4.2").
- 16) If the measurement is less than specified, check for air in the brake system. Section 7 (Supplemental System Bleeding) may need to be performed.

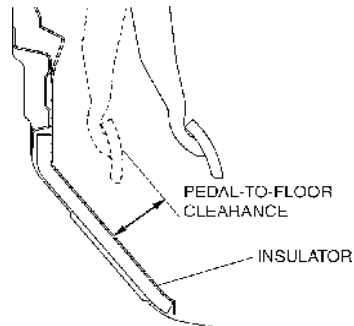

7 Supplemental System Bleeding

Note: Supplemental Bleeding requires a collection/suction tank, and Piston retractor tool (SST 49 0221 600C)

- 1) Remove the protective cap from the inboard bleed screw and slide the collection/suction tank hose, or supplied drain hose, over the bleed screw.

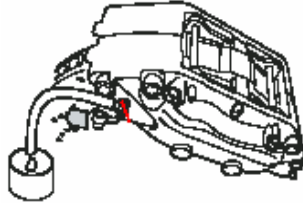

- 2) Repeatedly press the brake pedal, then keep the brake pedal pressed either by obtaining the assistance of another person, or by placing brake pedal depressor spacer tool in position as directed in the tool's instruction manual.

- 3) Loosen the bleed screw $\frac{1}{2}$ to $\frac{3}{4}$ of a turn, allowing fluid and air to escape. This time, **DO NOT** re-tighten after evacuation stops.

- 4) Use the retractor to push the pistons back into the caliper. This will force any air which was trapped out through the open bleed screw.

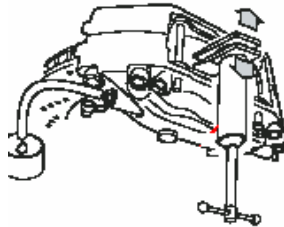

- 5) Make sure the brake pedal is down completely and tighten the bleed screw. Remember to keep the fluid in the reservoir between the min and max level.

- 6) Perform steps 7.1 to 7.5 on the outboard bleed screw.

- 7) Repeat steps 7.1 to 7.6 on the other side of the vehicle.

- 8) Torque all 4 bleed screws to 14 Nm.

- 9) Fill the system with fluid to the specified level marked on the side of the reservoir and install the reservoir cap.

- 10) Clean any fluid that may have escaped off components using soap and water. Then clean the brake rotors using brake cleaner by cleaning the half of the rotor that is away from the caliper, then dry, then rotate the rotor 180 degrees and clean the other side. Repeat on the other side of the vehicle.

- 11) Start the car and have a 2nd person press the brake pedal hard while you check the system to insure there are no leaks.

- 12) Check the pedal effort and travel; the travel per Section 6.

8 Test Drive

CAUTION: Do not use the vehicle in any situation where the brake system may need to be used heavily until the burnishing procedure (Section 9) is completed.

- 1) Carefully install the wheel, making sure not to contact the caliper. Refer to vehicle service manual, or wheel manufactures specifications on for proper torque.

- 2) While vehicle is still, stationary, and in park (or in neutral with the parking brake on), start the vehicle and pump the brake pedal to ensure a firm pedal, and ensure that with sustained pressure the pedal does not fall to the floor.

- 3) Remove from park and drive vehicle slowly (under 25mph) and cautiously to test function.

- 4) Verify brakes are smooth, with no vibrations, judder, noise, etc.

- 5) Return to the garage and stop on level ground. Press the brake pedal as hard as possible.

- 6) Inspect all joints on the new brake system, and the bleed screws, to insure there are no leaks.

9 Burnishing

CAUTION: Do not use the vehicle in any situation where the brake system may need to be used heavily until the burnishing procedure (Section 9) is completed.

Note: The purpose of this procedure is to gradually increase the temperature in the components without thermal shock, and to mate the brake pads and rotors.

- 1) Drive the vehicle to a remote area without traffic and perform at least 20 light/medium brake applications from 45mph with a duration of 3-5 seconds, with at least $\frac{1}{2}$ mile, or 40 seconds driving time, between each brake application. Do not come to a complete stop during these brake applications.

- 2) After the repeated stops, drive the vehicle for several miles with little or no braking in order to adequately cool the components.

The system is now ready for specified use.

10 Final Installation Notes

- 1) Pads must be inspected regularly to ensure that disc damage does not result due to overly worn pads. Pad wear depends greatly on driving environment and driver habits.

- 2) Perform brake system maintenance as outlined in the vehicle owners manual, with the exception of brake pad replacement.

- 3) Pads should be checked during each pit-stop. Pad wear can vary greatly depending on the driver and vehicle use. Pads are considered fully worn when the friction material reaches 2mm in thickness.

- 4) Most high performance brake pads will output more dust and noise than OEM brake pads.