

# SYSTEM WIRING DIAGRAMS

## Article Text

1994 Mazda Miata

For Yorba Linda Miata

Copyright © 1998 Mitchell Repair Information Company, LLC

Saturday, May 10, 2003 11:28AM

### ARTICLE BEGINNING

1994 System Wiring Diagrams  
Mazda - Miata

### AIR CONDITIONING

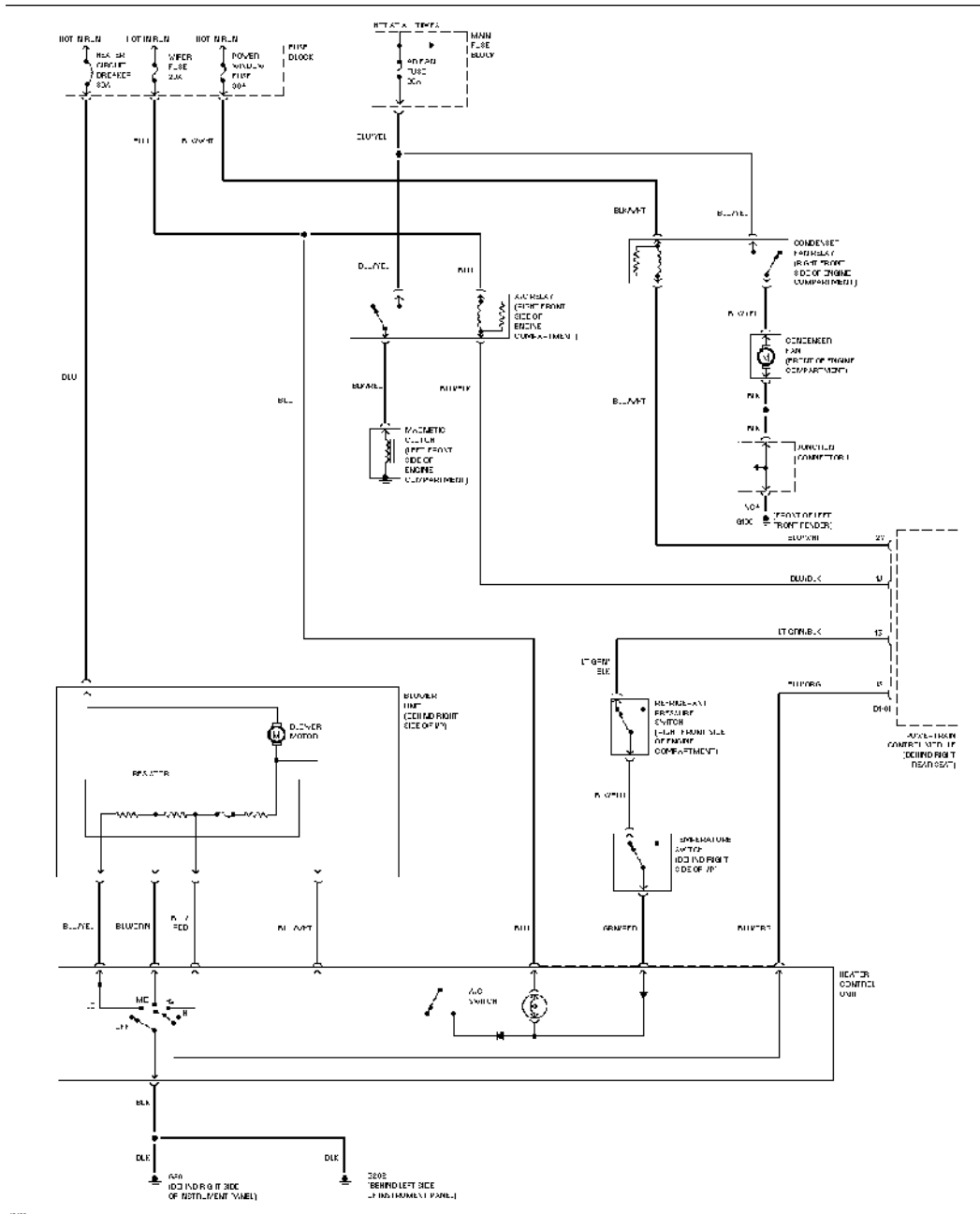

A/C Circuit

# SYSTEM WIRING DIAGRAMS

## Article Text (p. 2)

1994 Mazda Miata

For Yorba Linda Miata

Copyright © 1998 Mitchell Repair Information Company, LLC

Saturday, May 10, 2003 11:28AM

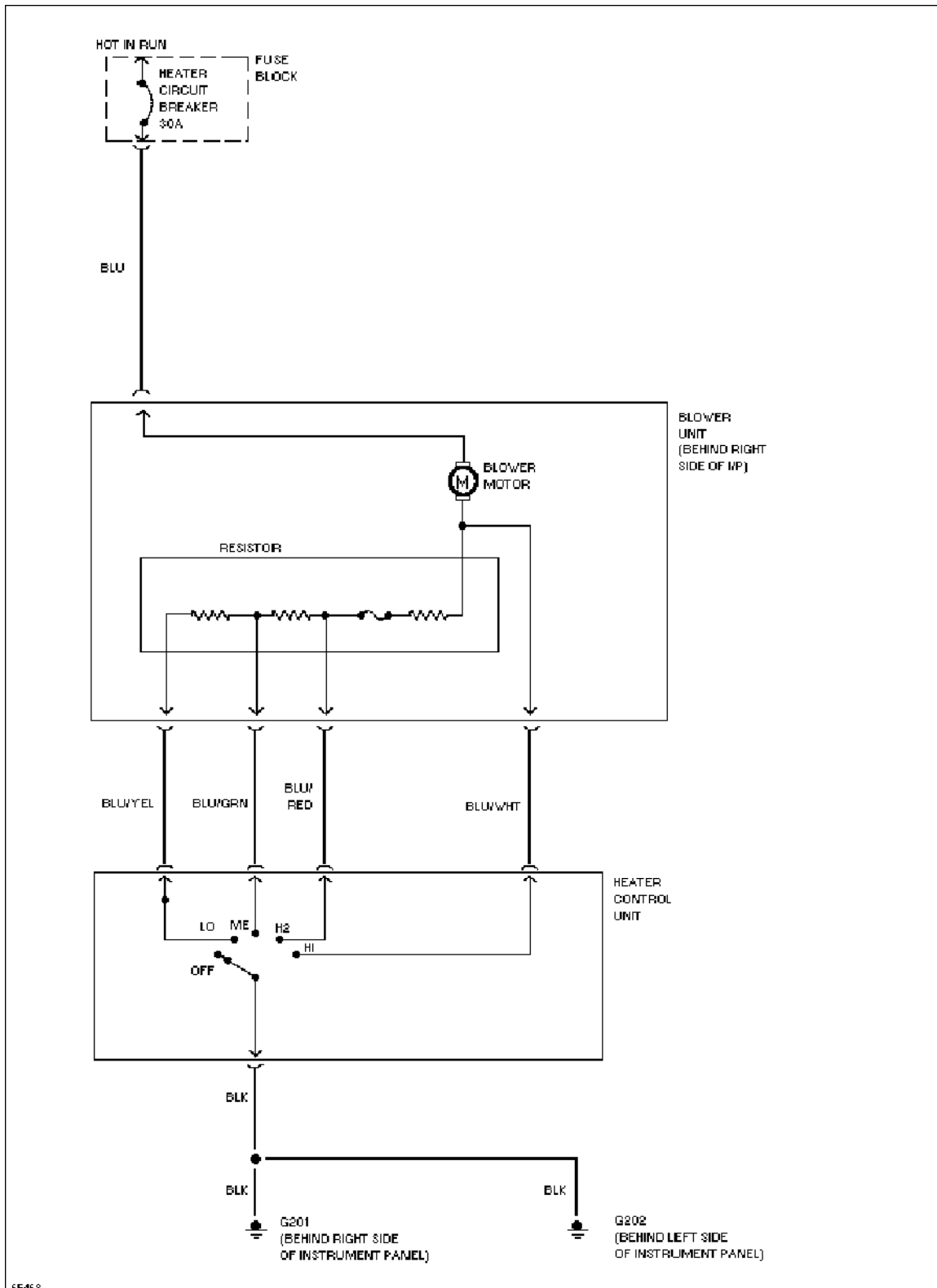

Heater Circuit

# SYSTEM WIRING DIAGRAMS

## Article Text (p. 3)

1994 Mazda Miata

For Yorba Linda Miata

Copyright © 1998 Mitchell Repair Information Company, LLC

Saturday, May 10, 2003 11:28AM

### ANTI-LOCK BRAKES

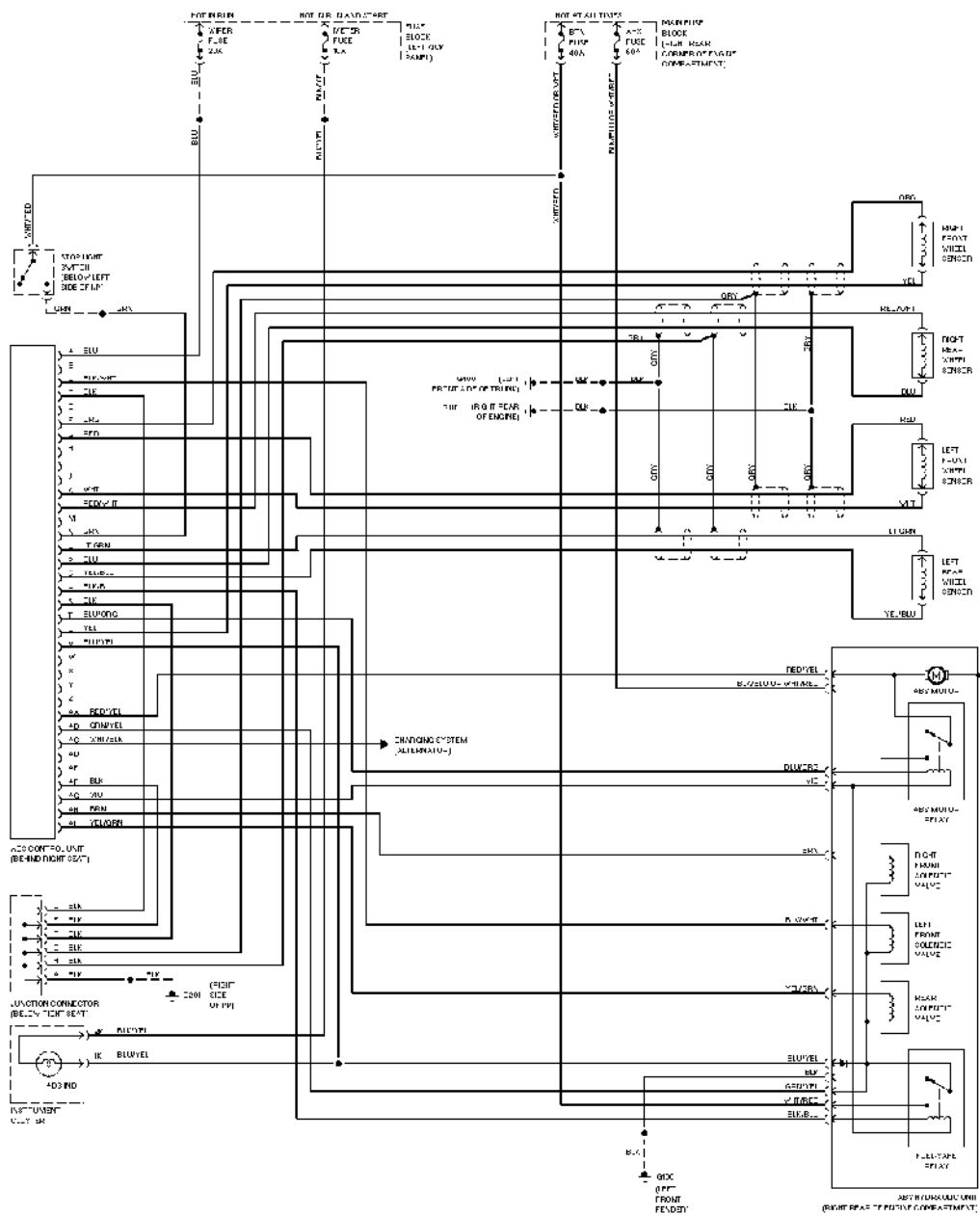

Anti-lock Brake Circuits

### COMPUTER DATA LINES

# SYSTEM WIRING DIAGRAMS

Article Text (p. 4)

1994 Mazda Miata

For Yorba Linda Miata

Copyright © 1998 Mitchell Repair Information Company, LLC

Saturday, May 10, 2003 11:28AM

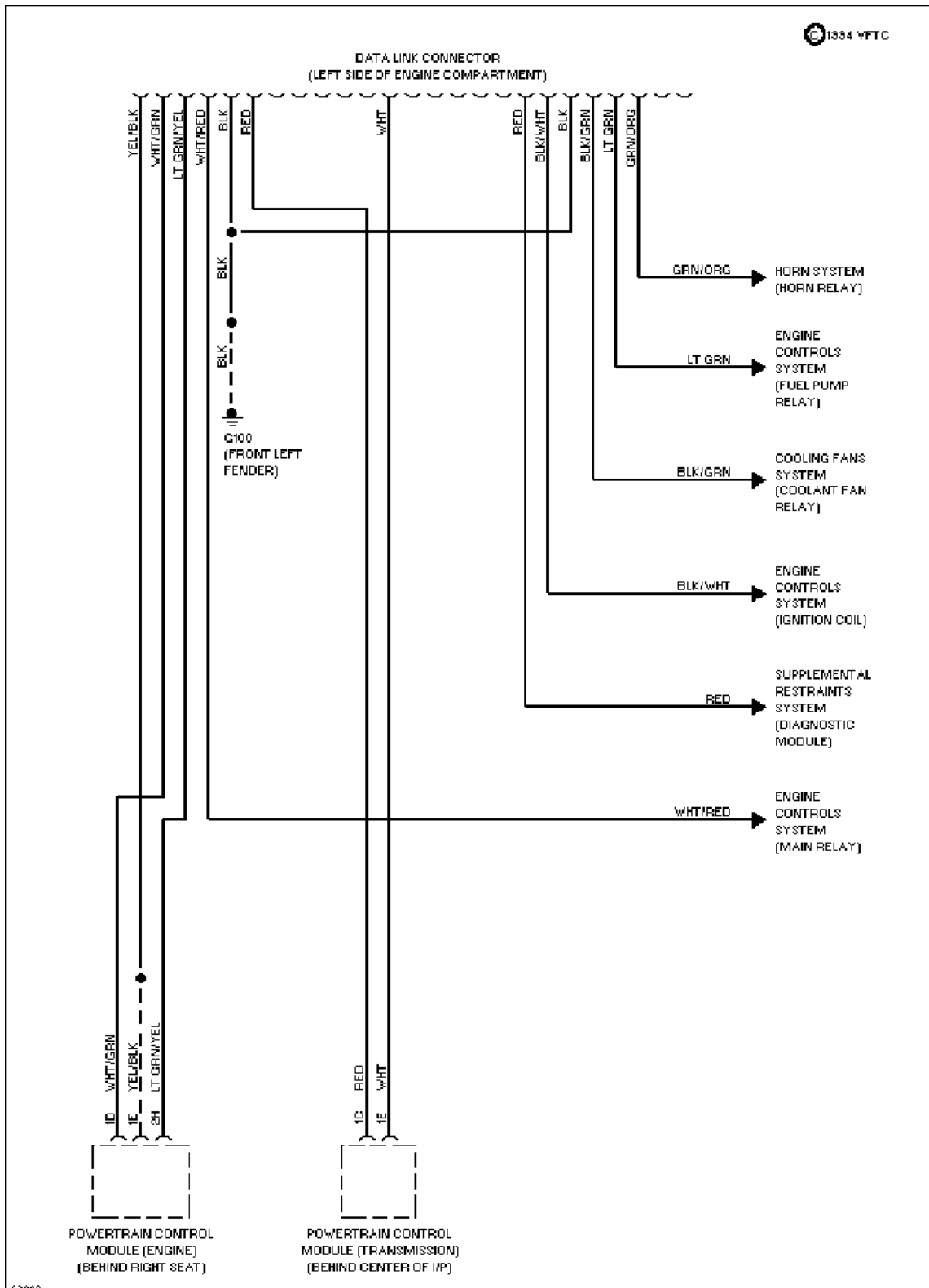

Data Link Connector Circuit

# SYSTEM WIRING DIAGRAMS

Article Text (p. 5)

1994 Mazda Miata

For Yorba Linda Miata

Copyright © 1998 Mitchell Repair Information Company, LLC

Saturday, May 10, 2003 11:28AM

## COOLING FAN

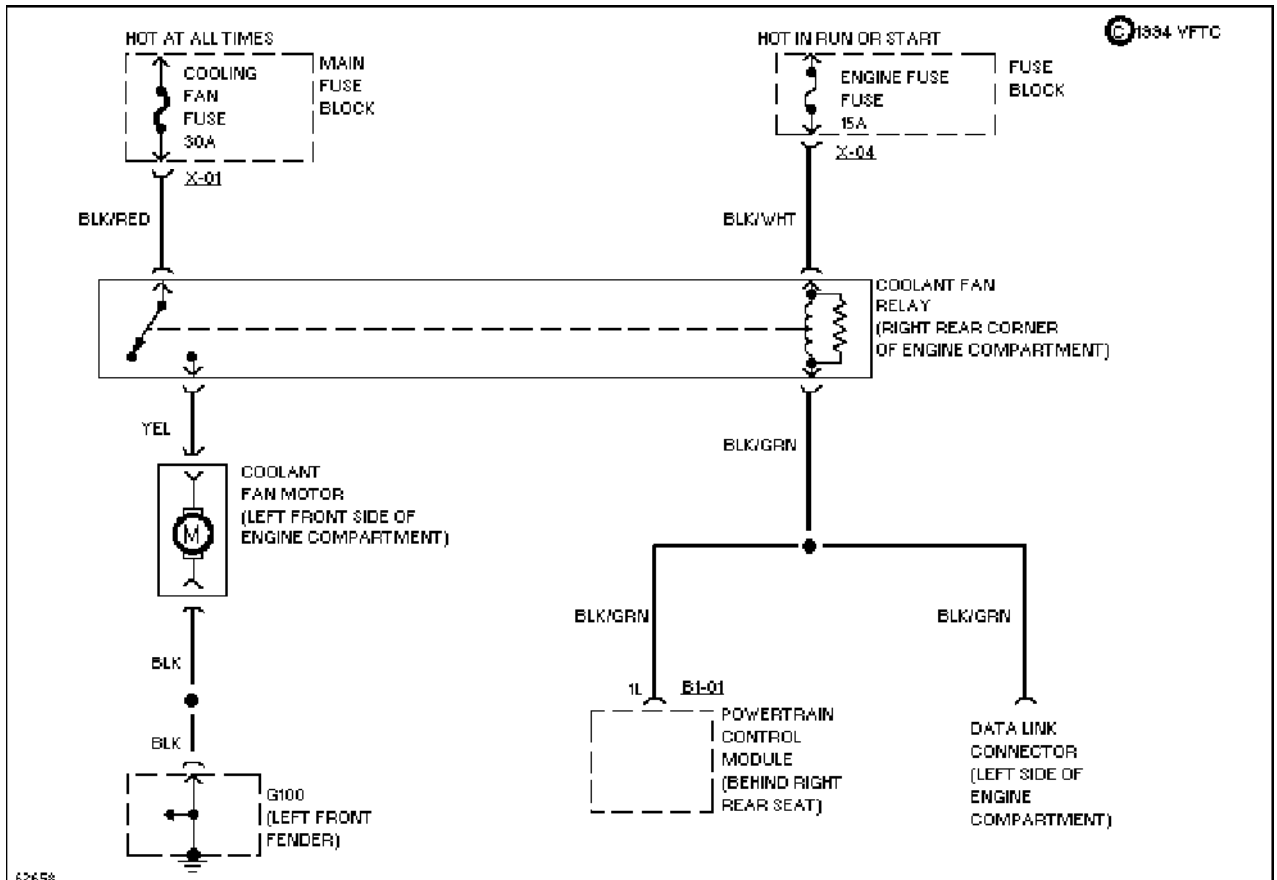

62658  
Cooling Fan Circuit

## CRUISE CONTROL

# SYSTEM WIRING DIAGRAMS

Article Text (p. 6)

1994 Mazda Miata

For Yorba Linda Miata

Copyright © 1998 Mitchell Repair Information Company, LLC

Saturday, May 10, 2003 11:28AM

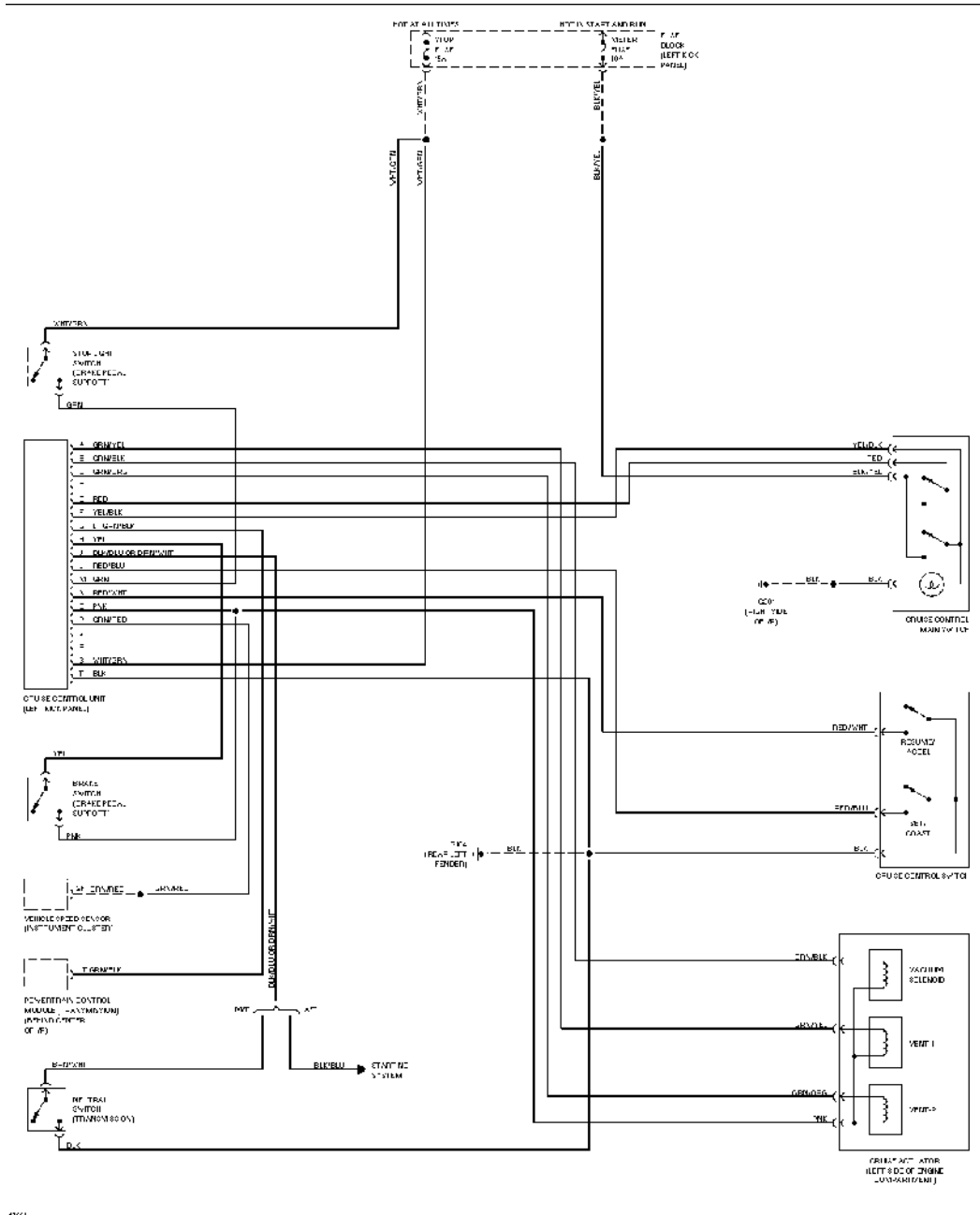

Cruise Control Circuit

## DEFOGGERS

# SYSTEM WIRING DIAGRAMS

## Article Text (p. 7)

1994 Mazda Miata

For Yorba Linda Miata

Copyright © 1998 Mitchell Repair Information Company, LLC

Saturday, May 10, 2003 11:28AM

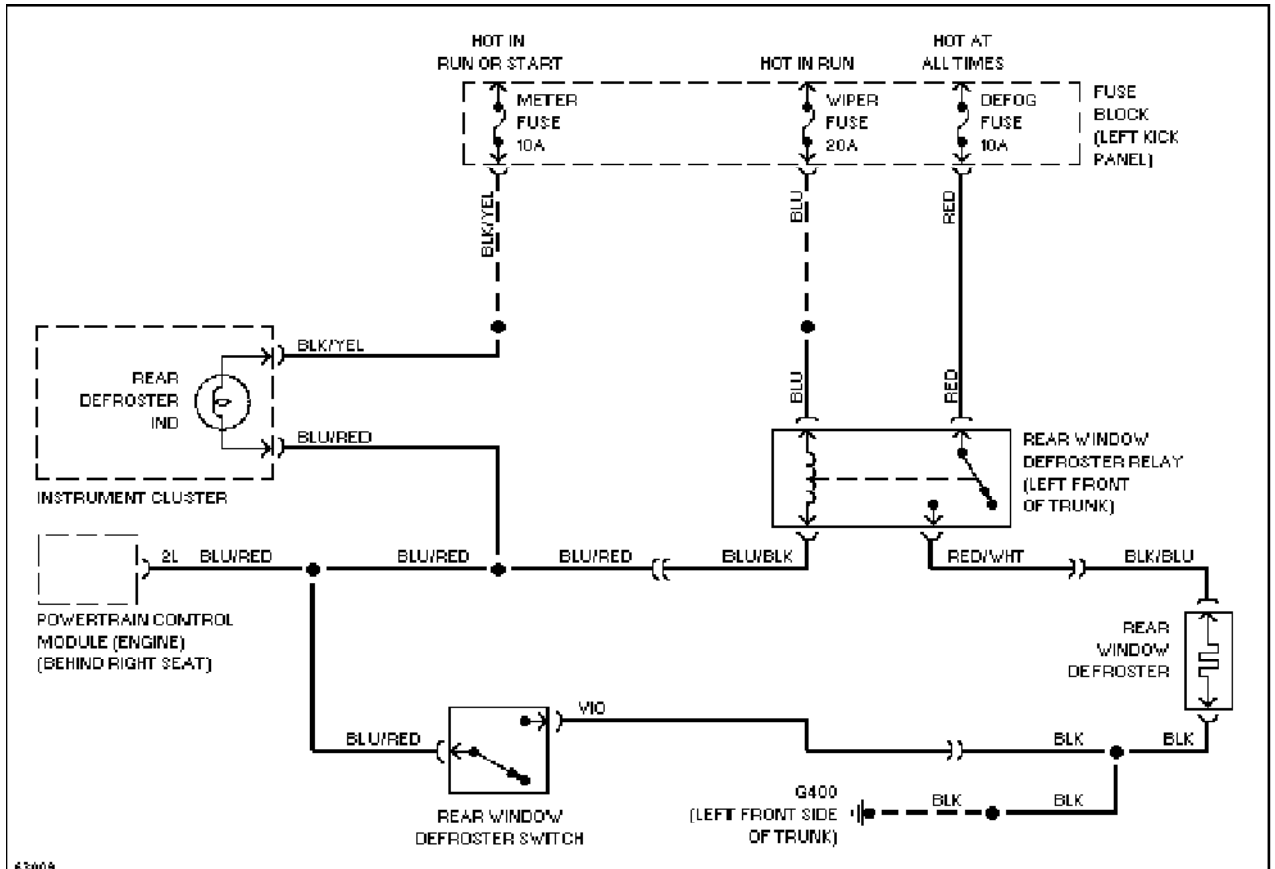

63009  
Defogger Circuit

## ENGINE PERFORMANCE

1.8L

# SYSTEM WIRING DIAGRAMS

Article Text (p. 8)

1994 Mazda Miata

For Yorba Linda Miata

Copyright © 1998 Mitchell Repair Information Company, LLC

Saturday, May 10, 2003 11:28AM

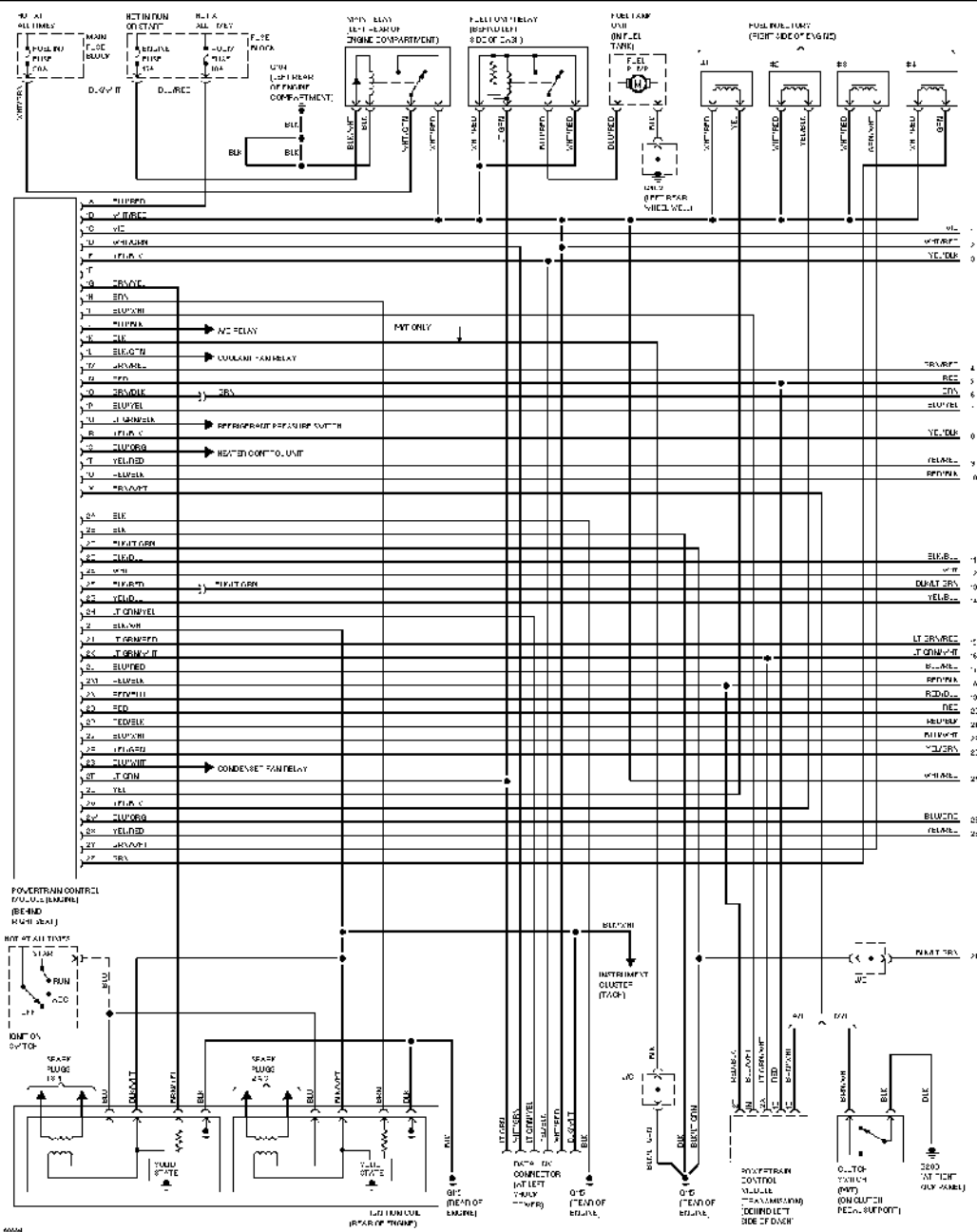

1.8L, Engine Performance Circuits (1 of 2)

# SYSTEM WIRING DIAGRAMS

Article Text (p. 9)

1994 Mazda Miata

For Yorba Linda Miata

Copyright © 1998 Mitchell Repair Information Company, LLC

Saturday, May 10, 2003 11:28AM

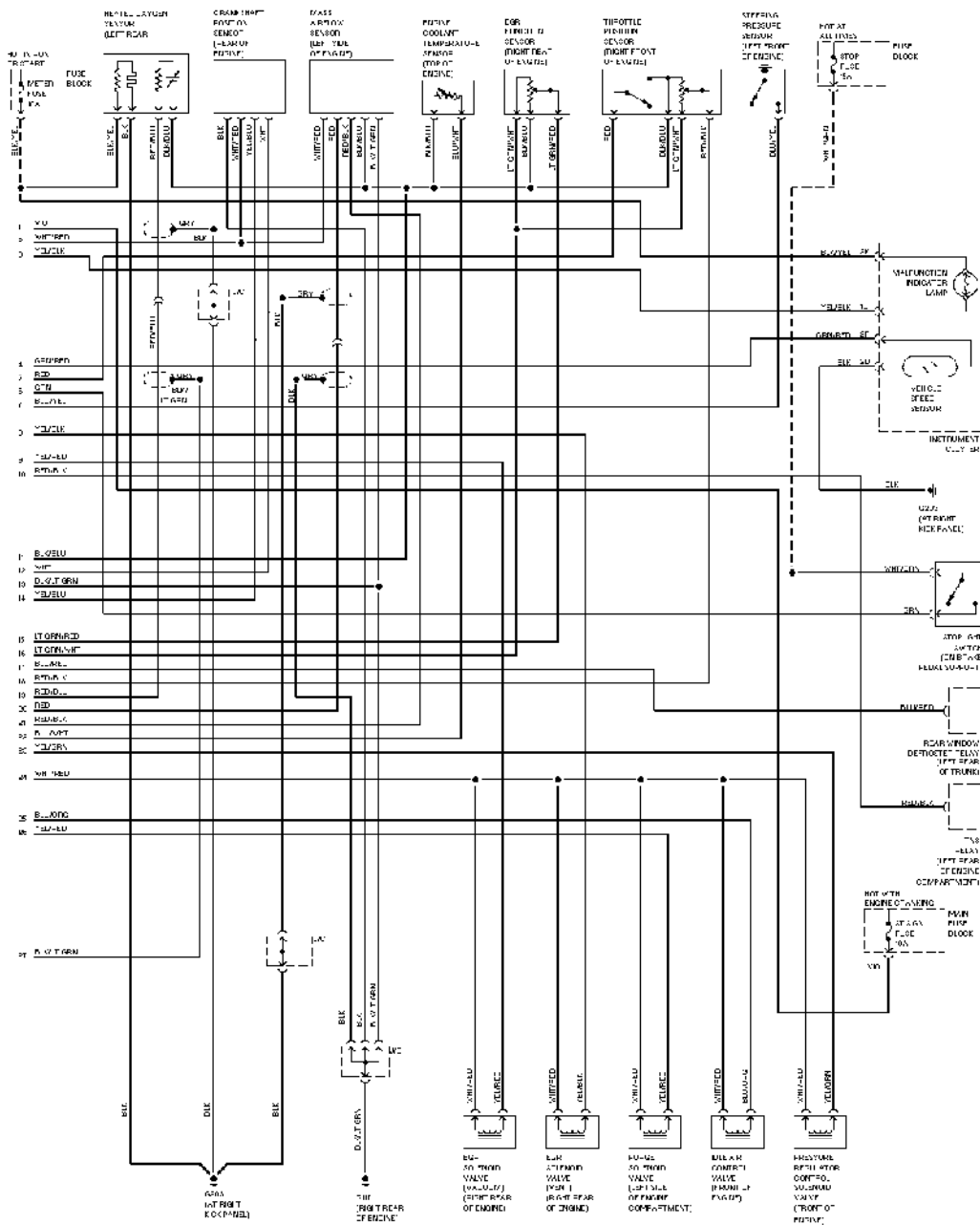

1.8L, Engine Performance Circuits (2 of 2)

## EXTERIOR LIGHTS

# SYSTEM WIRING DIAGRAMS

Article Text (p. 10)

1994 Mazda Miata

For Yorba Linda Miata

Copyright © 1998 Mitchell Repair Information Company, LLC

Saturday, May 10, 2003 11:28AM

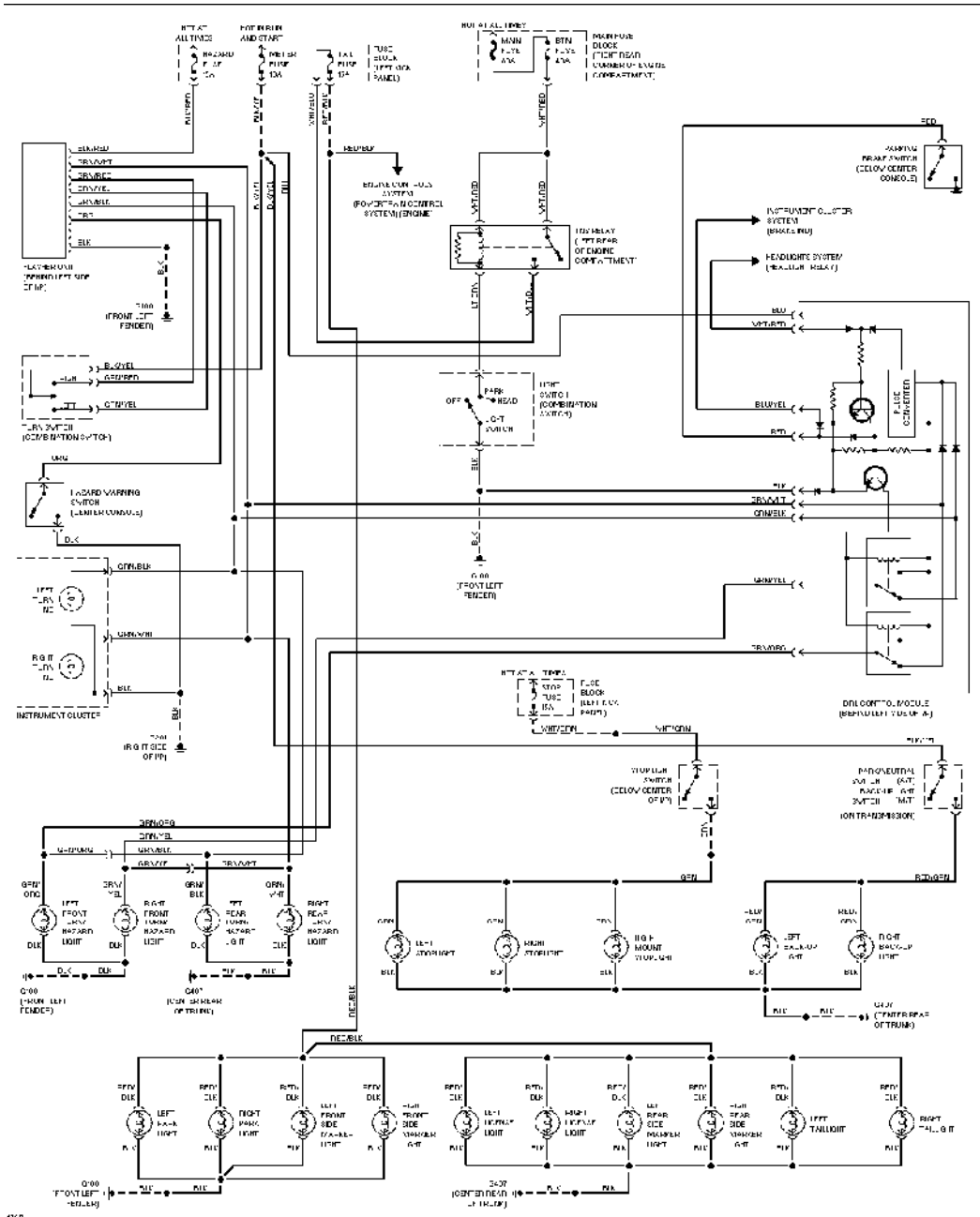

Exterior Light Circuit, W/ DRL

# SYSTEM WIRING DIAGRAMS

Article Text (p. 11)

1994 Mazda Miata

For Yorba Linda Miata

Copyright © 1998 Mitchell Repair Information Company, LLC

Saturday, May 10, 2003 11:28AM

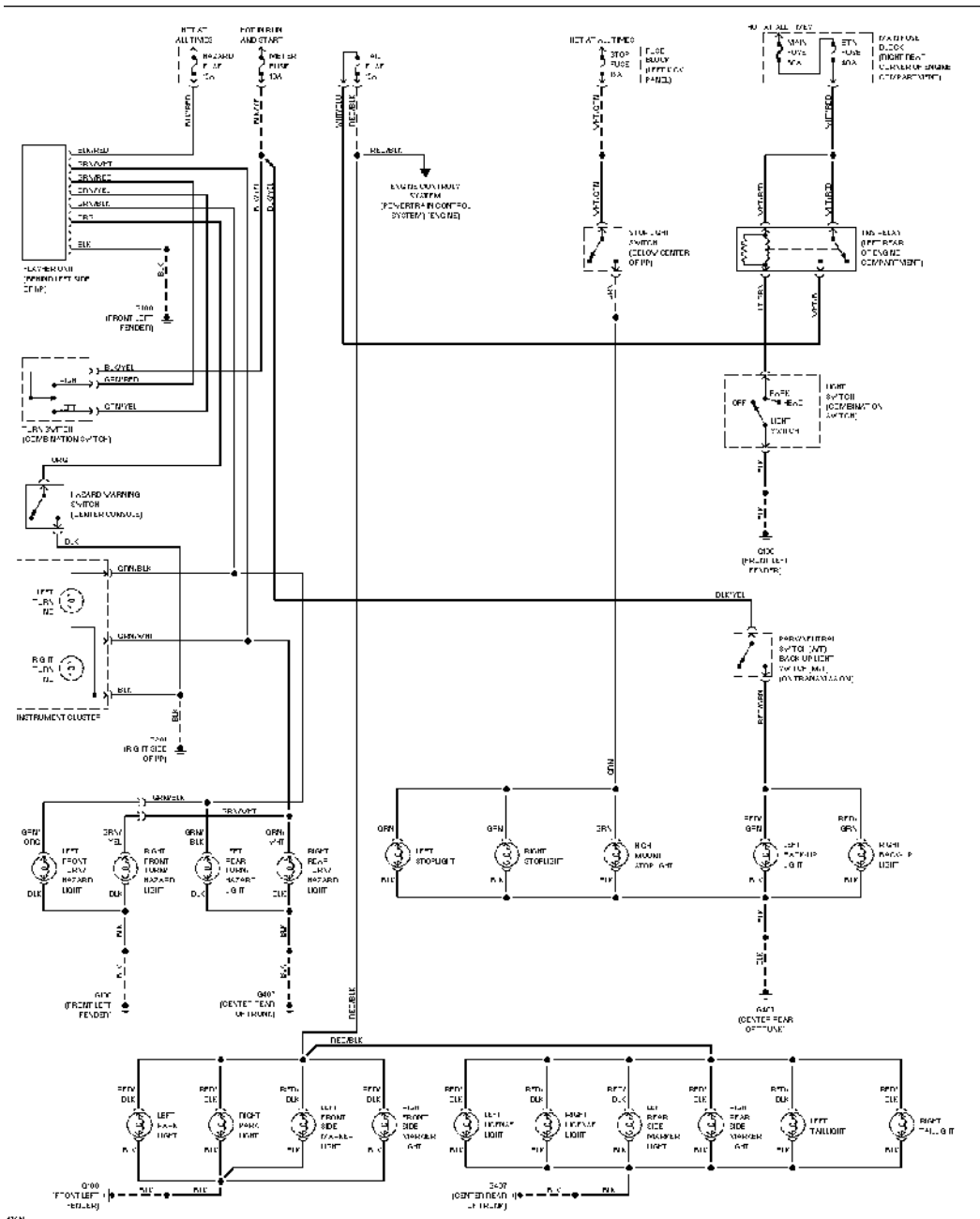

Exterior Light Circuit, W/O DRL

## GROUND DISTRIBUTION

# SYSTEM WIRING DIAGRAMS

Article Text (p. 12)

1994 Mazda Miata

For Yorba Linda Miata

Copyright © 1998 Mitchell Repair Information Company, LLC

Saturday, May 10, 2003 11:28AM

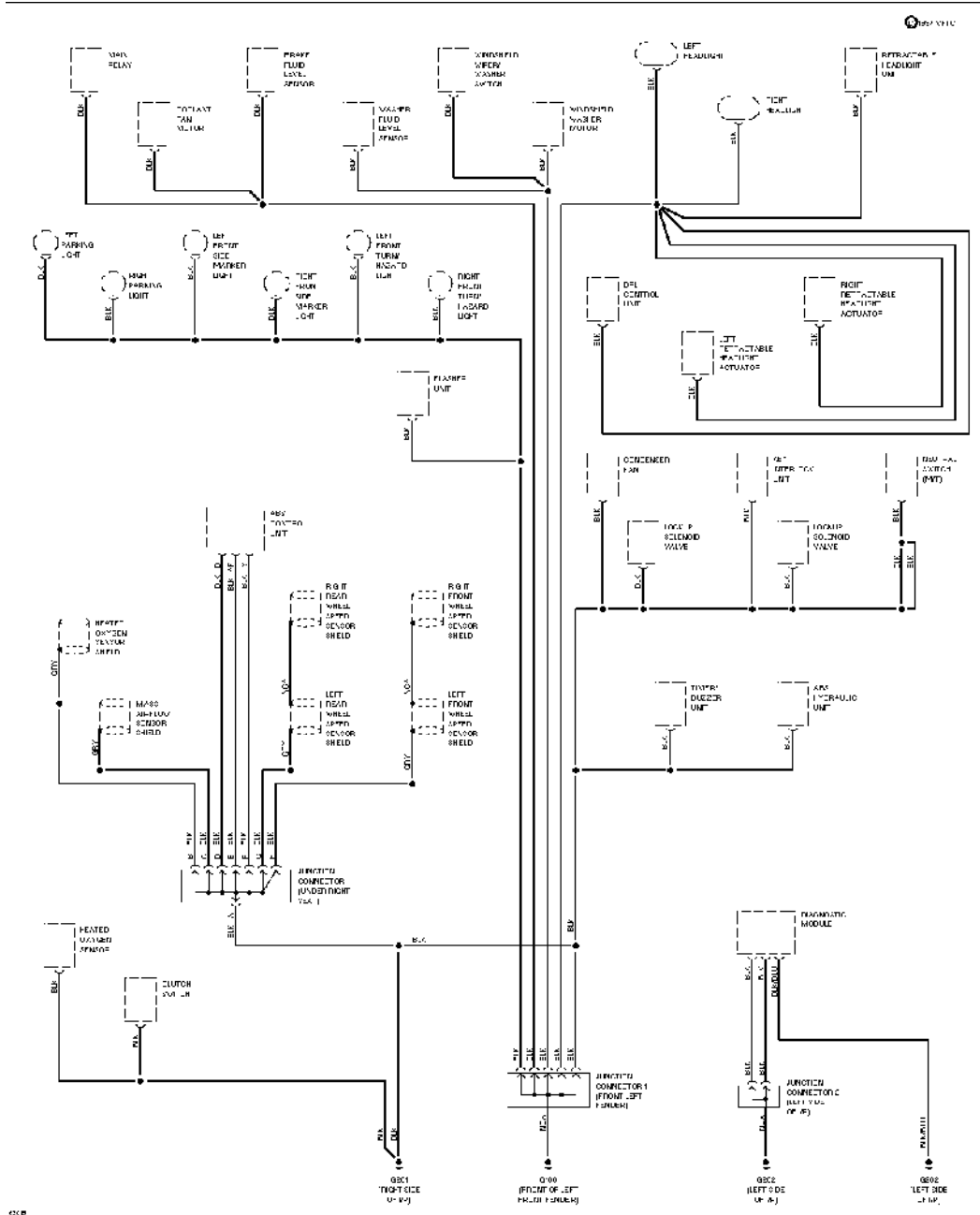

Ground Distribution Circuit (1 of 2)



# SYSTEM WIRING DIAGRAMS

Article Text (p. 14)

1994 Mazda Miata

For Yorba Linda Miata

Copyright © 1998 Mitchell Repair Information Company, LLC

Saturday, May 10, 2003 11:28AM

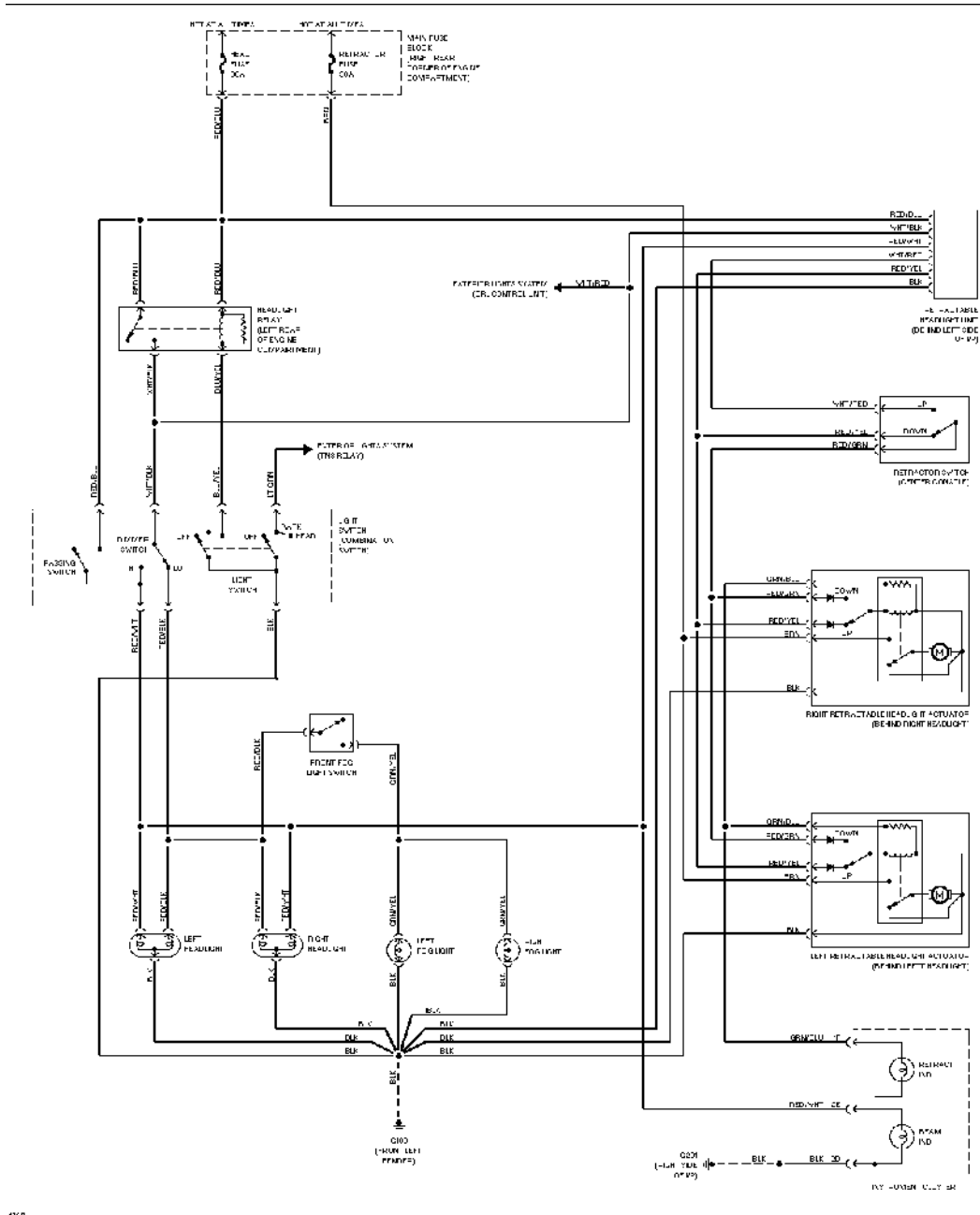

Headlight Circuit

## HORN

# SYSTEM WIRING DIAGRAMS

Article Text (p. 15)

1994 Mazda Miata

For Yorba Linda Miata

Copyright © 1998 Mitchell Repair Information Company, LLC

Saturday, May 10, 2003 11:28AM

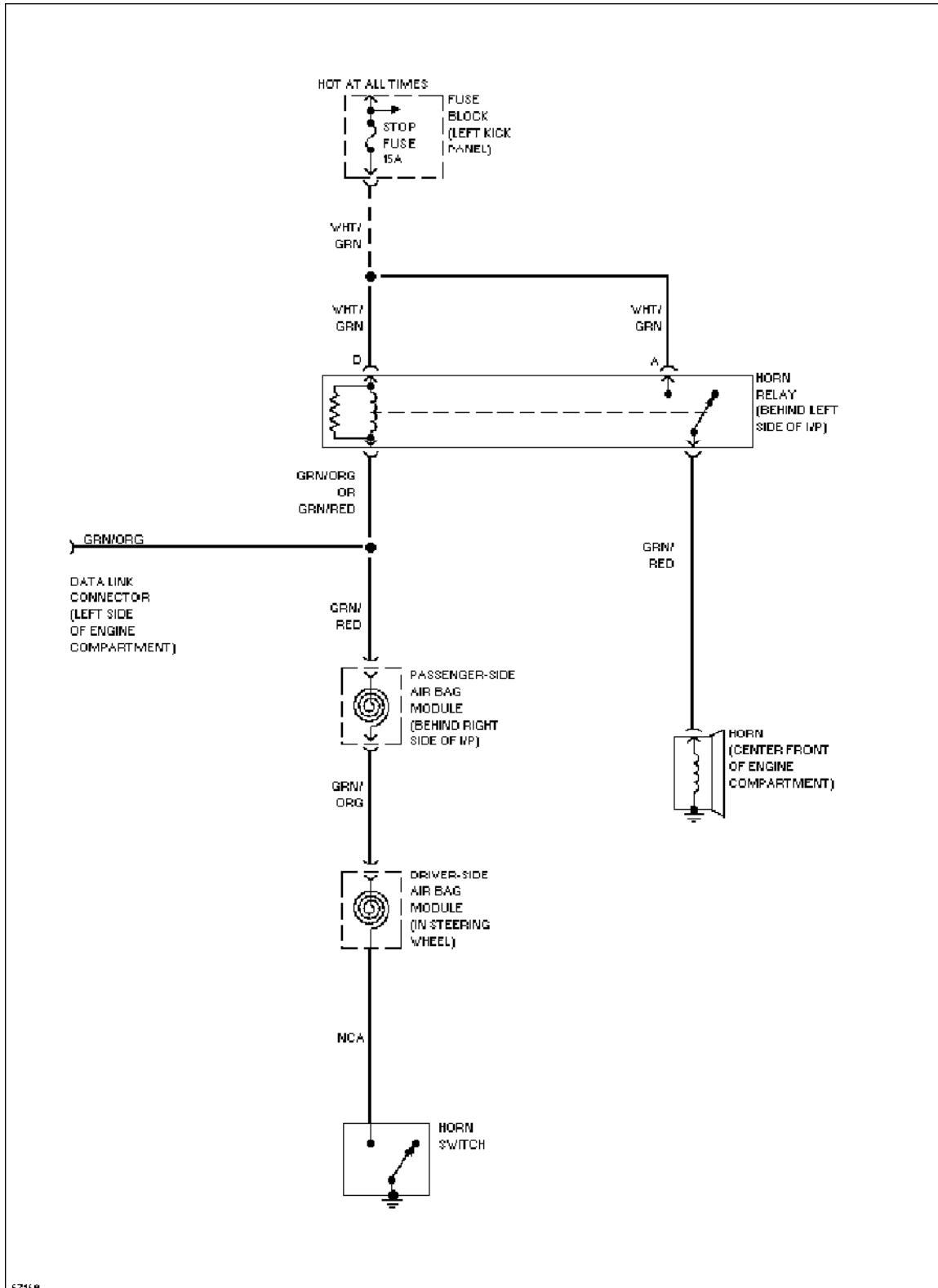

Horn Circuit

**SYSTEM WIRING DIAGRAMS**  
**Article Text (p. 16)**  
 1994 Mazda Miata  
 For Yorba Linda Miata  
 Copyright © 1998 Mitchell Repair Information Company, LLC  
 Saturday, May 10, 2003 11:28AM

**INSTRUMENT CLUSTER**

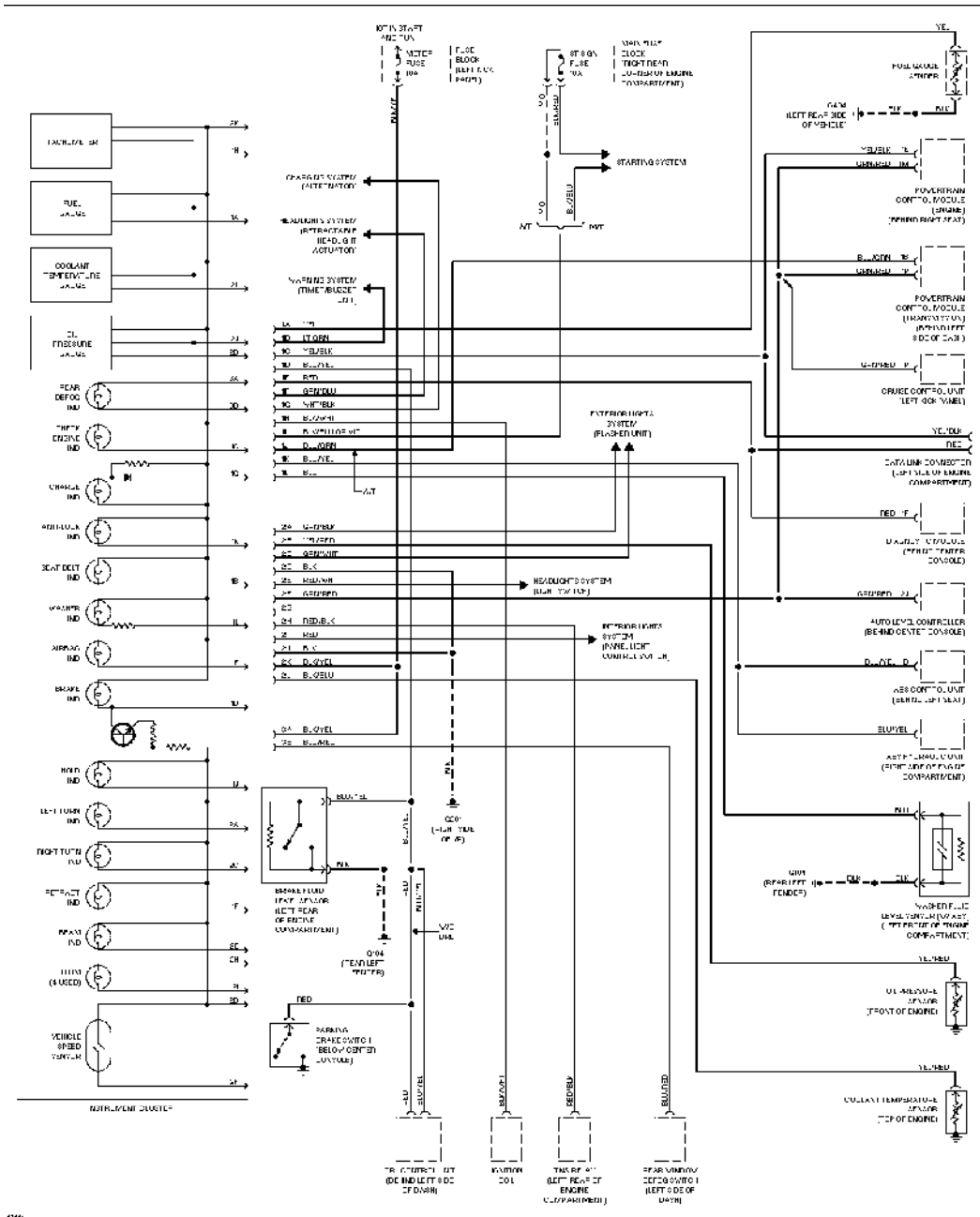

Instrument Cluster Circuit

**INTERIOR LIGHTS**

# SYSTEM WIRING DIAGRAMS

Article Text (p. 17)

1994 Mazda Miata

For Yorba Linda Miata

Copyright © 1998 Mitchell Repair Information Company, LLC

Saturday, May 10, 2003 11:28AM

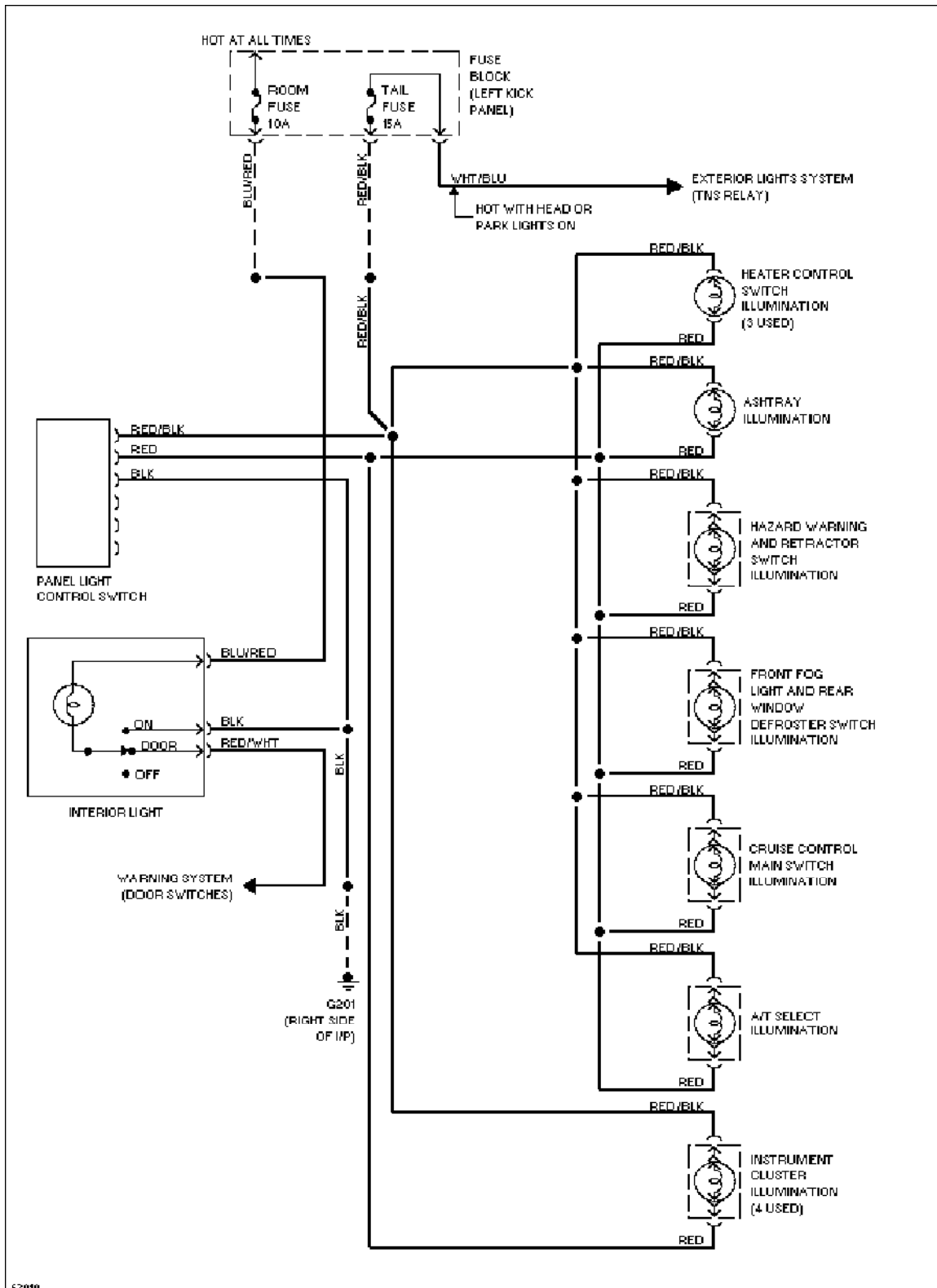

Interior Light Circuit

# SYSTEM WIRING DIAGRAMS

Article Text (p. 18)

1994 Mazda Miata

For Yorba Linda Miata

Copyright © 1998 Mitchell Repair Information Company, LLC

Saturday, May 10, 2003 11:28AM

## POWER ANTENNA

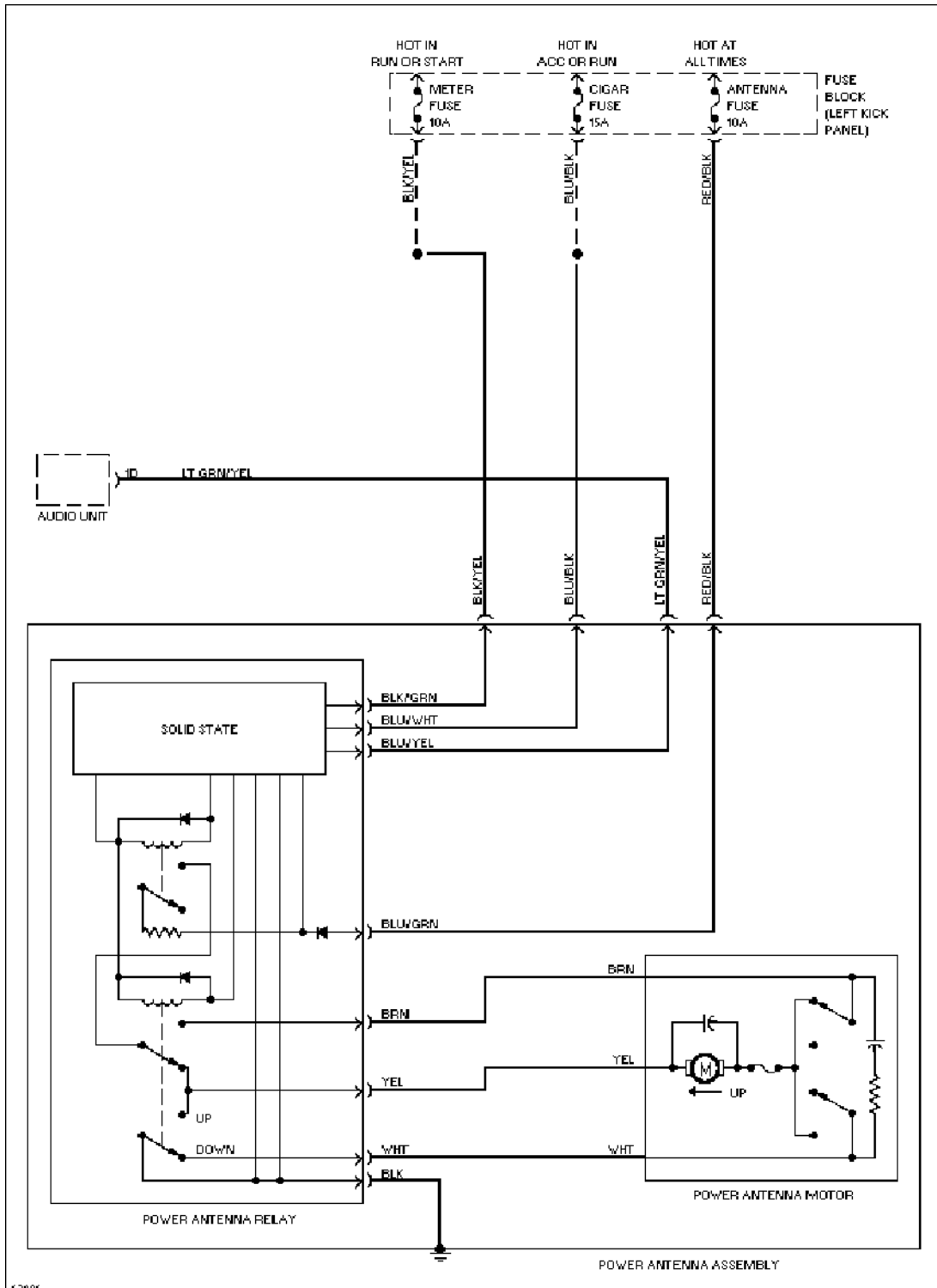

Power Antenna Circuit

# SYSTEM WIRING DIAGRAMS

Article Text (p. 19)

1994 Mazda Miata

For Yorba Linda Miata

Copyright © 1998 Mitchell Repair Information Company, LLC

Saturday, May 10, 2003 11:28AM

## POWER DISTRIBUTION

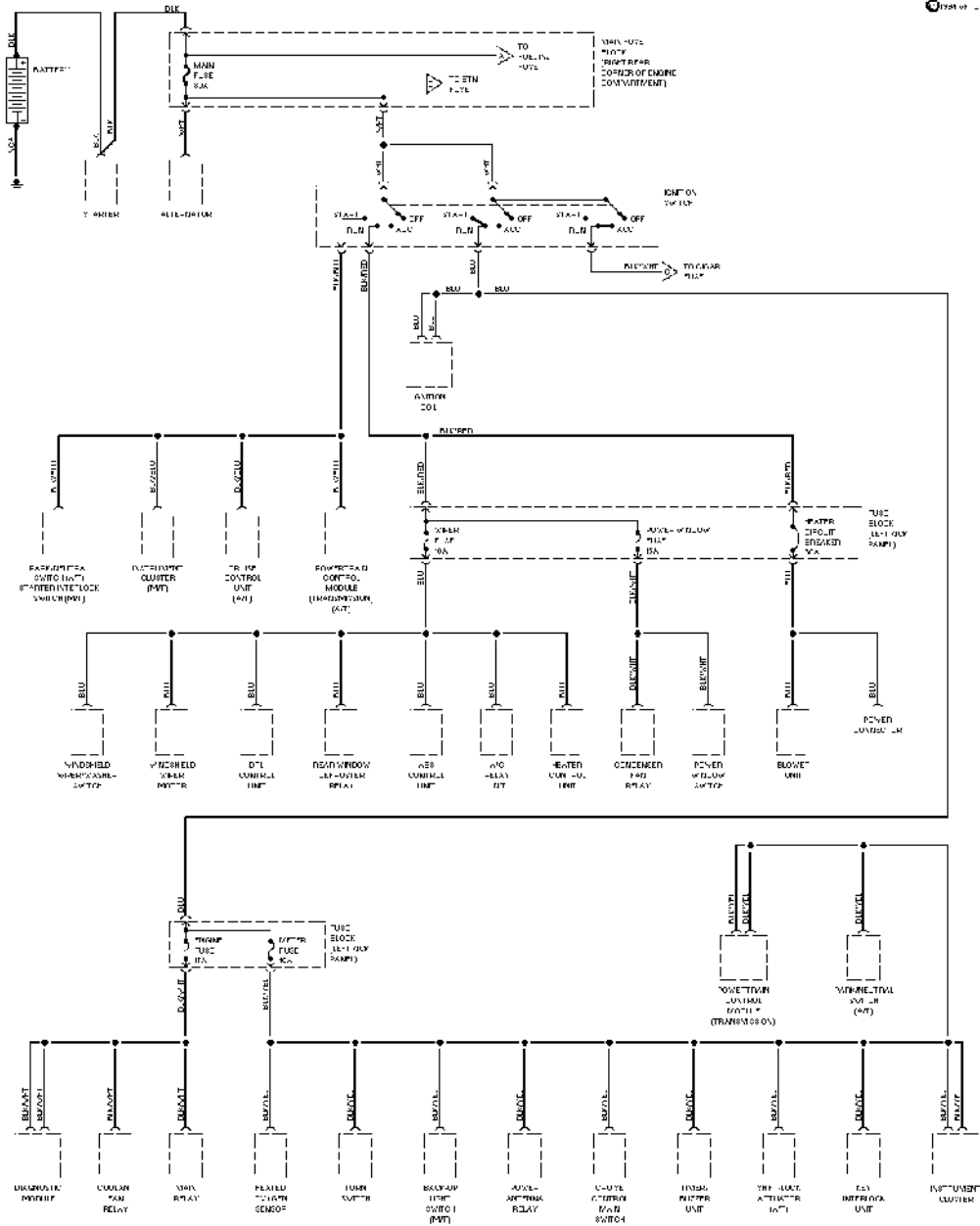

Power Distribution Circuit (1 of 3)

# SYSTEM WIRING DIAGRAMS

Article Text (p. 20)

1994 Mazda Miata

For Yorba Linda Miata

Copyright © 1998 Mitchell Repair Information Company, LLC

Saturday, May 10, 2003 11:28AM

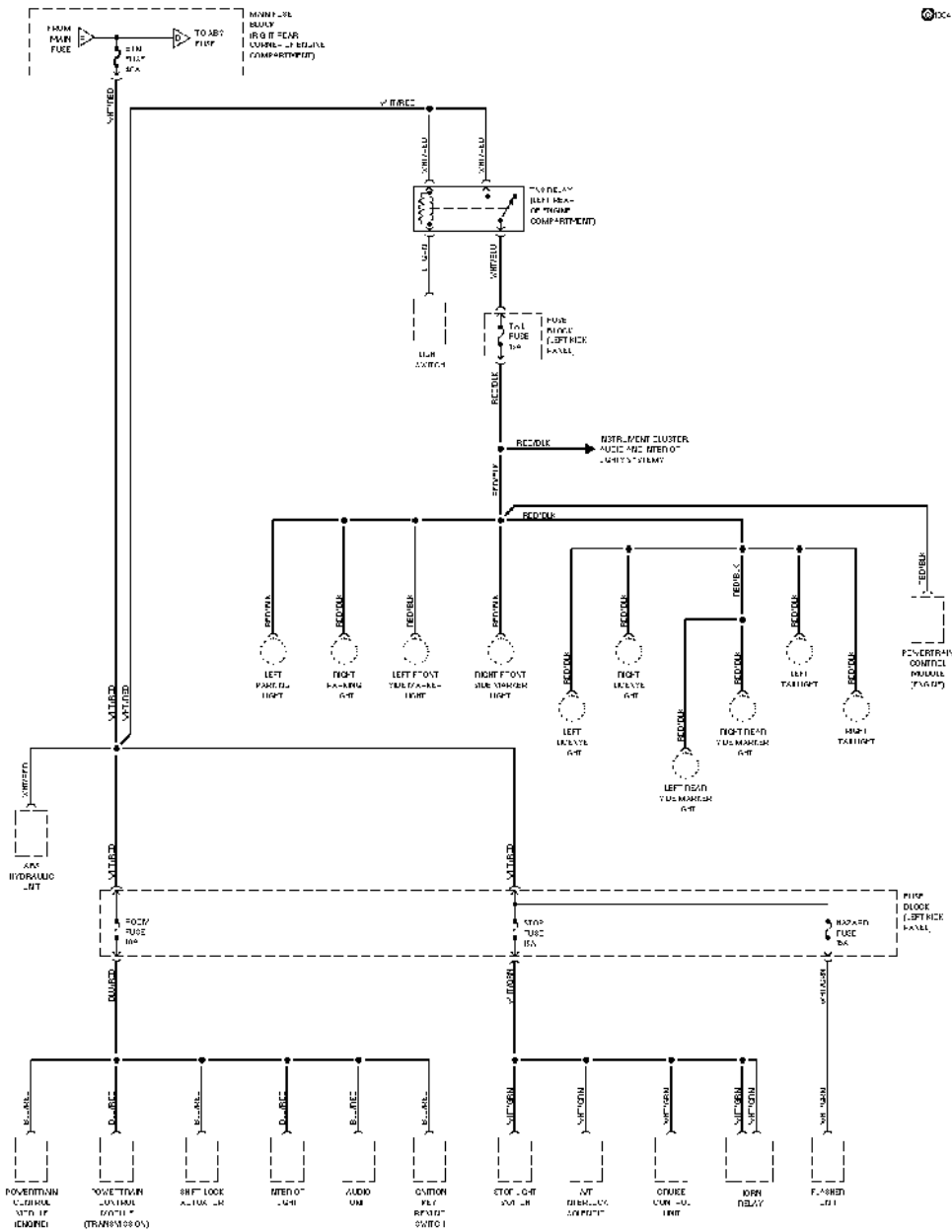

Power Distribution Circuit (2 of 3)

# SYSTEM WIRING DIAGRAMS

Article Text (p. 21)

1994 Mazda Miata

For Yorba Linda Miata

Copyright © 1998 Mitchell Repair Information Company, LLC

Saturday, May 10, 2003 11:28AM

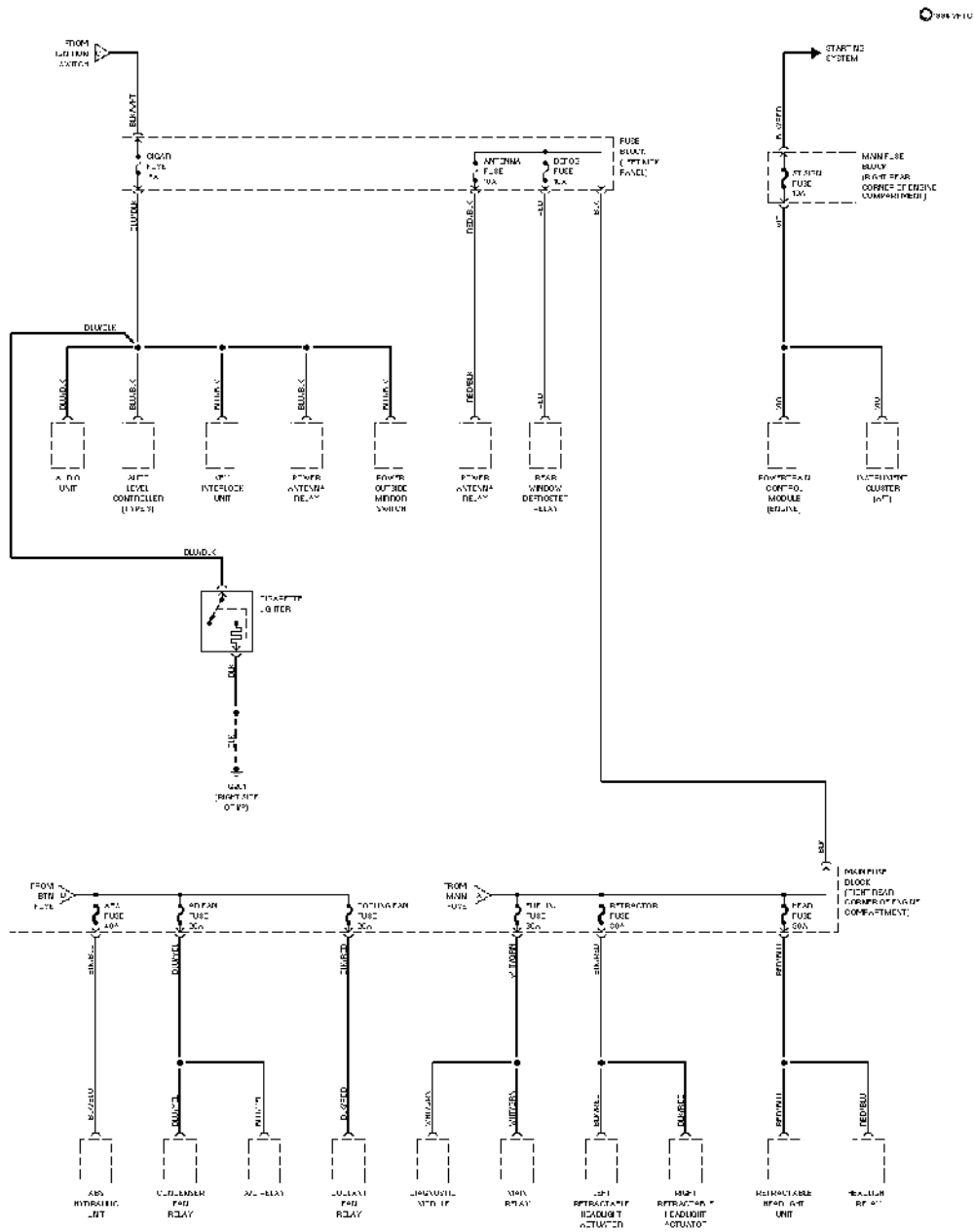

Power Distribution Circuit (3 of 3)

## POWER MIRRORS

# SYSTEM WIRING DIAGRAMS

Article Text (p. 22)

1994 Mazda Miata

For Yorba Linda Miata

Copyright © 1998 Mitchell Repair Information Company, LLC

Saturday, May 10, 2003 11:28AM

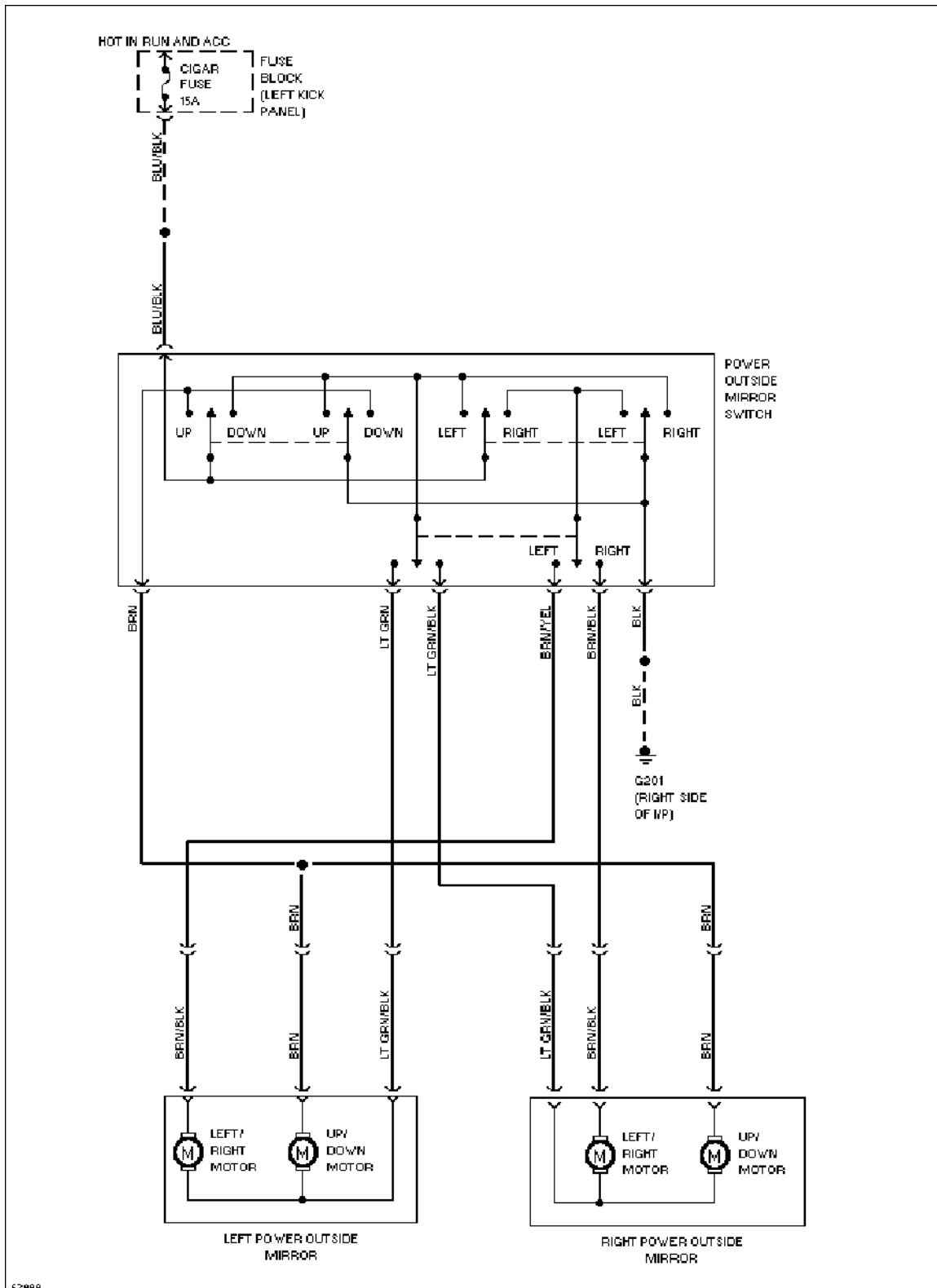

Power Mirror Circuit

# SYSTEM WIRING DIAGRAMS

Article Text (p. 23)

1994 Mazda Miata

For Yorba Linda Miata

Copyright © 1998 Mitchell Repair Information Company, LLC

Saturday, May 10, 2003 11:28AM

## POWER WINDOWS

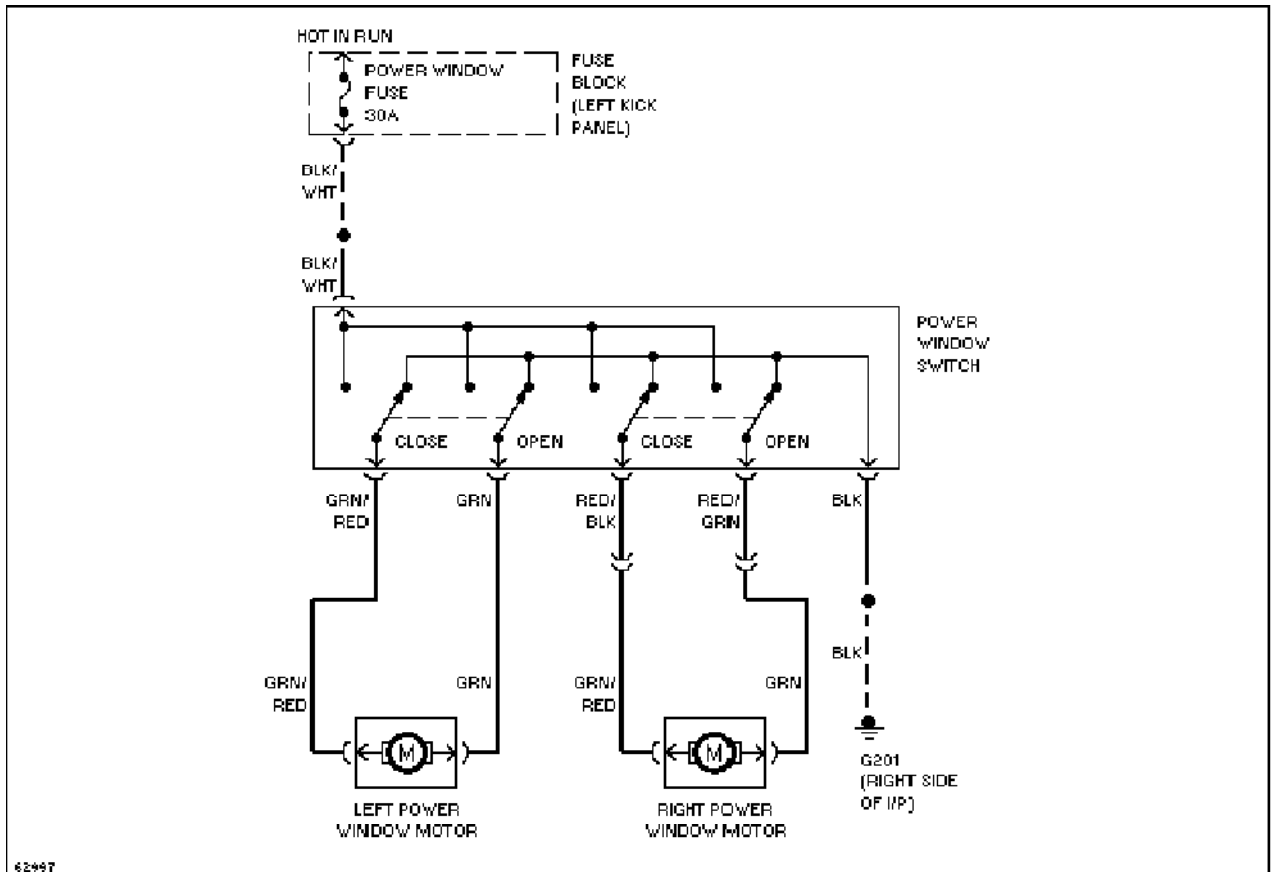

Power Window Circuit

## RADIO

# SYSTEM WIRING DIAGRAMS

Article Text (p. 24)

1994 Mazda Miata

For Yorba Linda Miata

Copyright © 1998 Mitchell Repair Information Company, LLC

Saturday, May 10, 2003 11:28AM

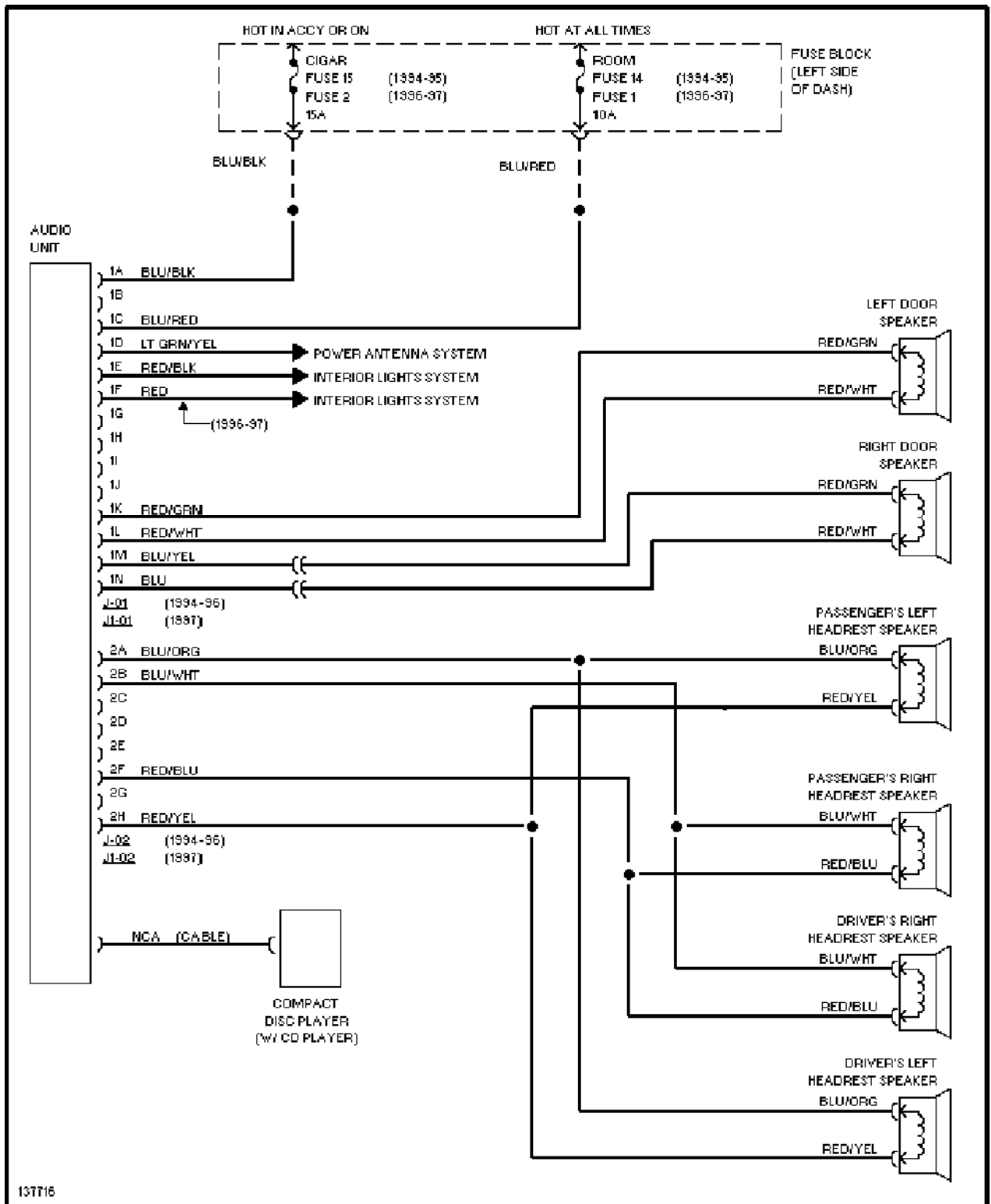

137715

Base Radio

# SYSTEM WIRING DIAGRAMS

Article Text (p. 25)

1994 Mazda Miata

For Yorba Linda Miata

Copyright © 1998 Mitchell Repair Information Company, LLC

Saturday, May 10, 2003 11:28AM

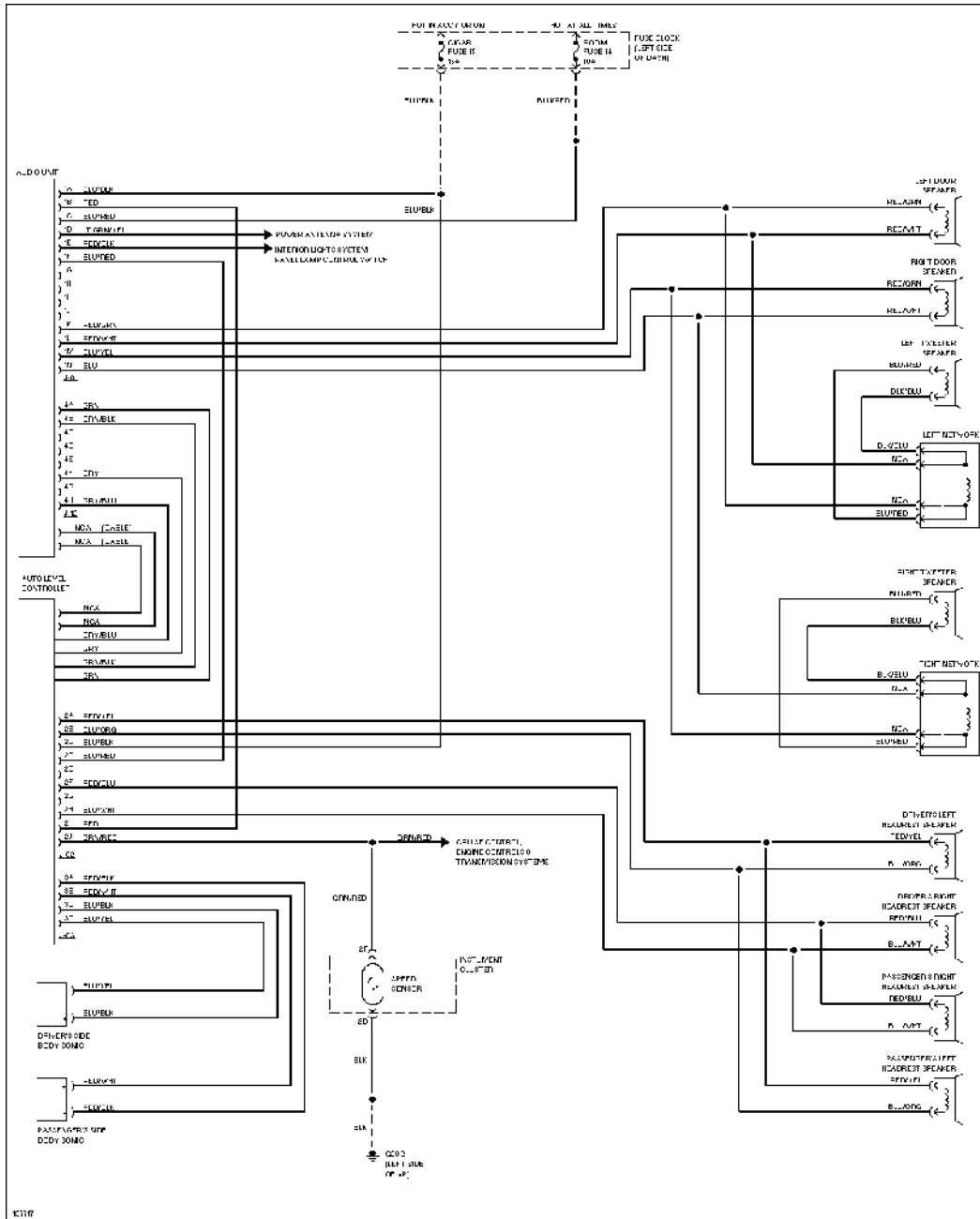

Premium Sound Radio Circuit

## SHIFT INTERLOCKS

# SYSTEM WIRING DIAGRAMS

Article Text (p. 26)

1994 Mazda Miata

For Yorba Linda Miata

Copyright © 1998 Mitchell Repair Information Company, LLC

Saturday, May 10, 2003 11:28AM

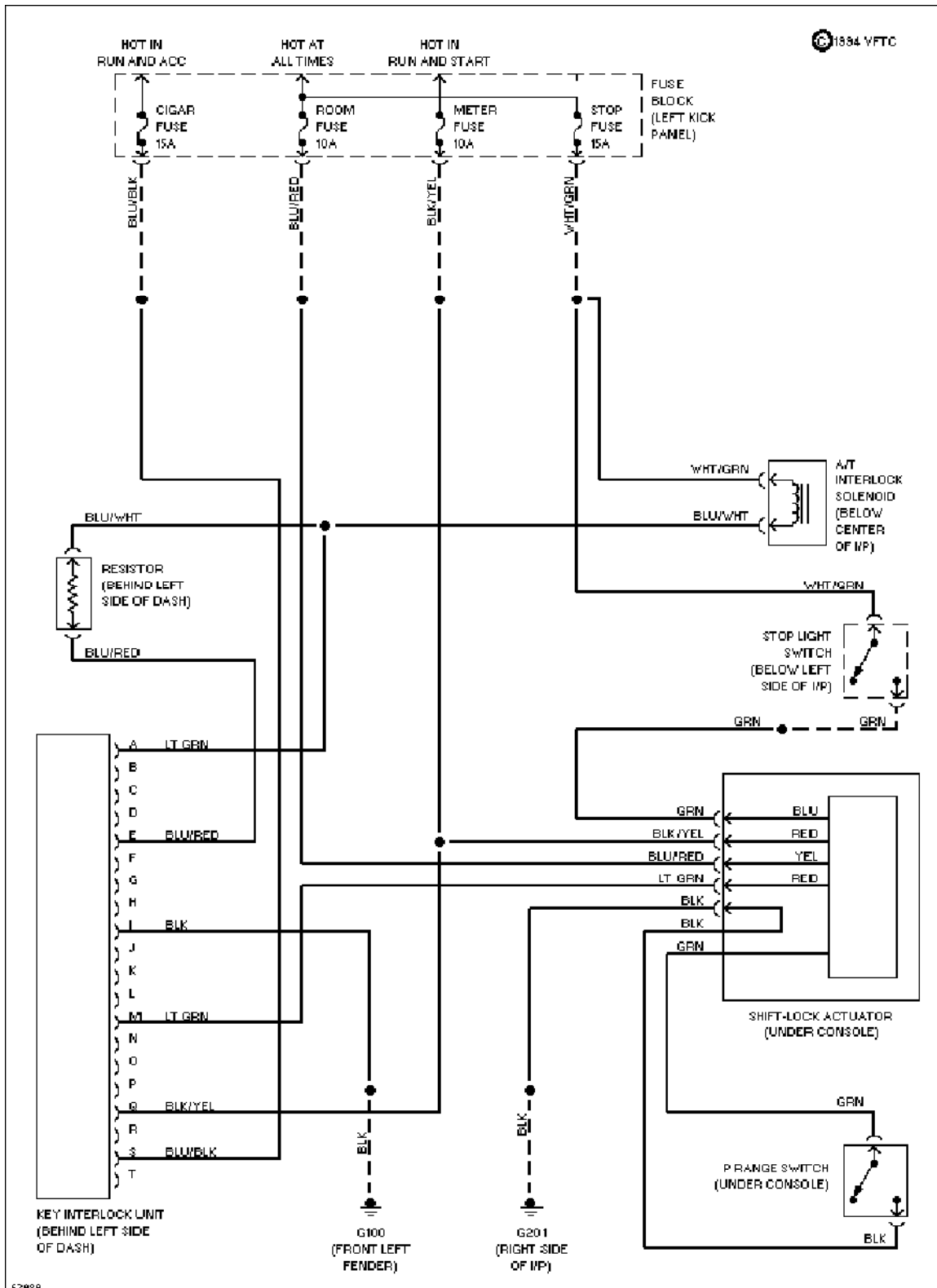

Shift Interlock Circuit

# SYSTEM WIRING DIAGRAMS

Article Text (p. 27)

1994 Mazda Miata

For Yorba Linda Miata

Copyright © 1998 Mitchell Repair Information Company, LLC

Saturday, May 10, 2003 11:28AM

## STARTING/CHARGING

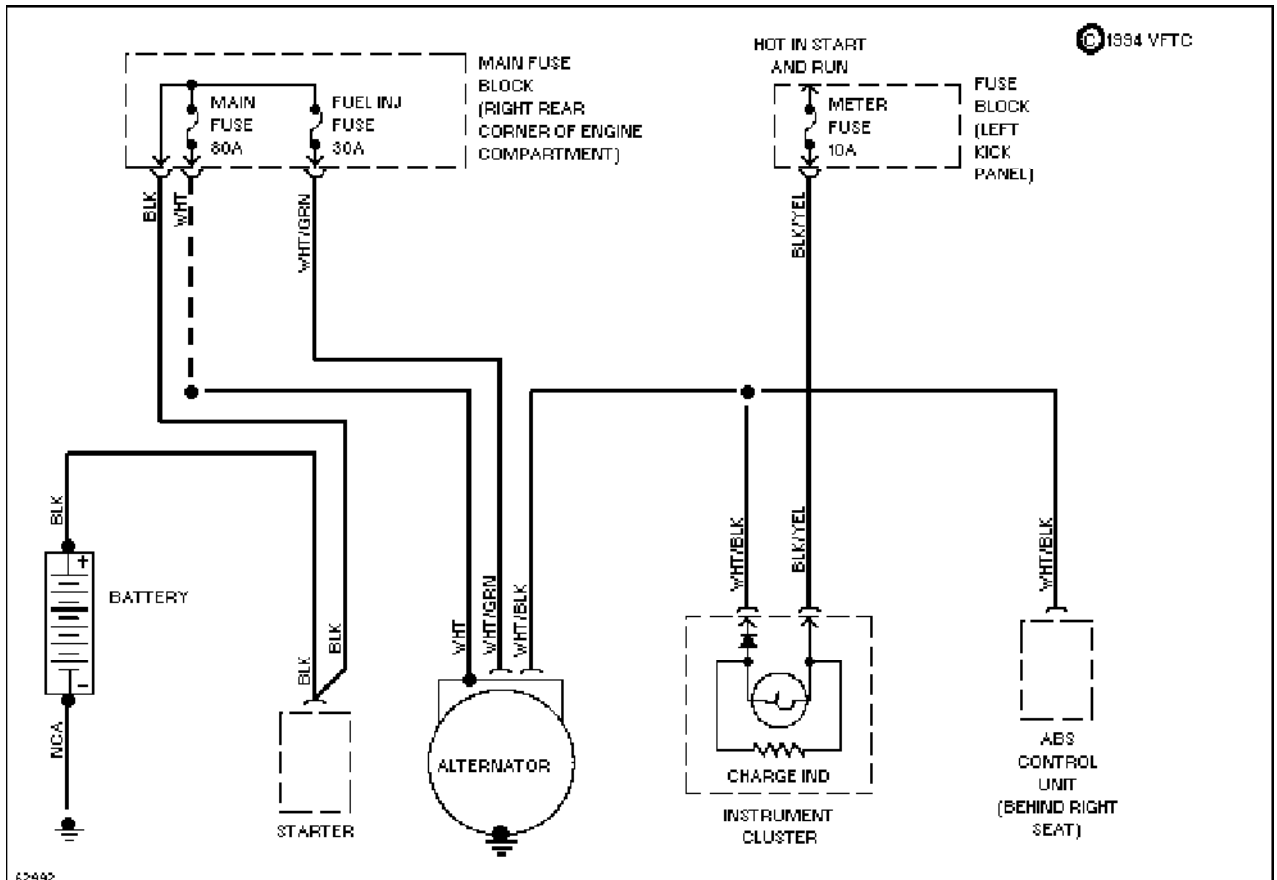

Charging Circuit

# SYSTEM WIRING DIAGRAMS

Article Text (p. 28)

1994 Mazda Miata

For Yorba Linda Miata

Copyright © 1998 Mitchell Repair Information Company, LLC

Saturday, May 10, 2003 11:28AM

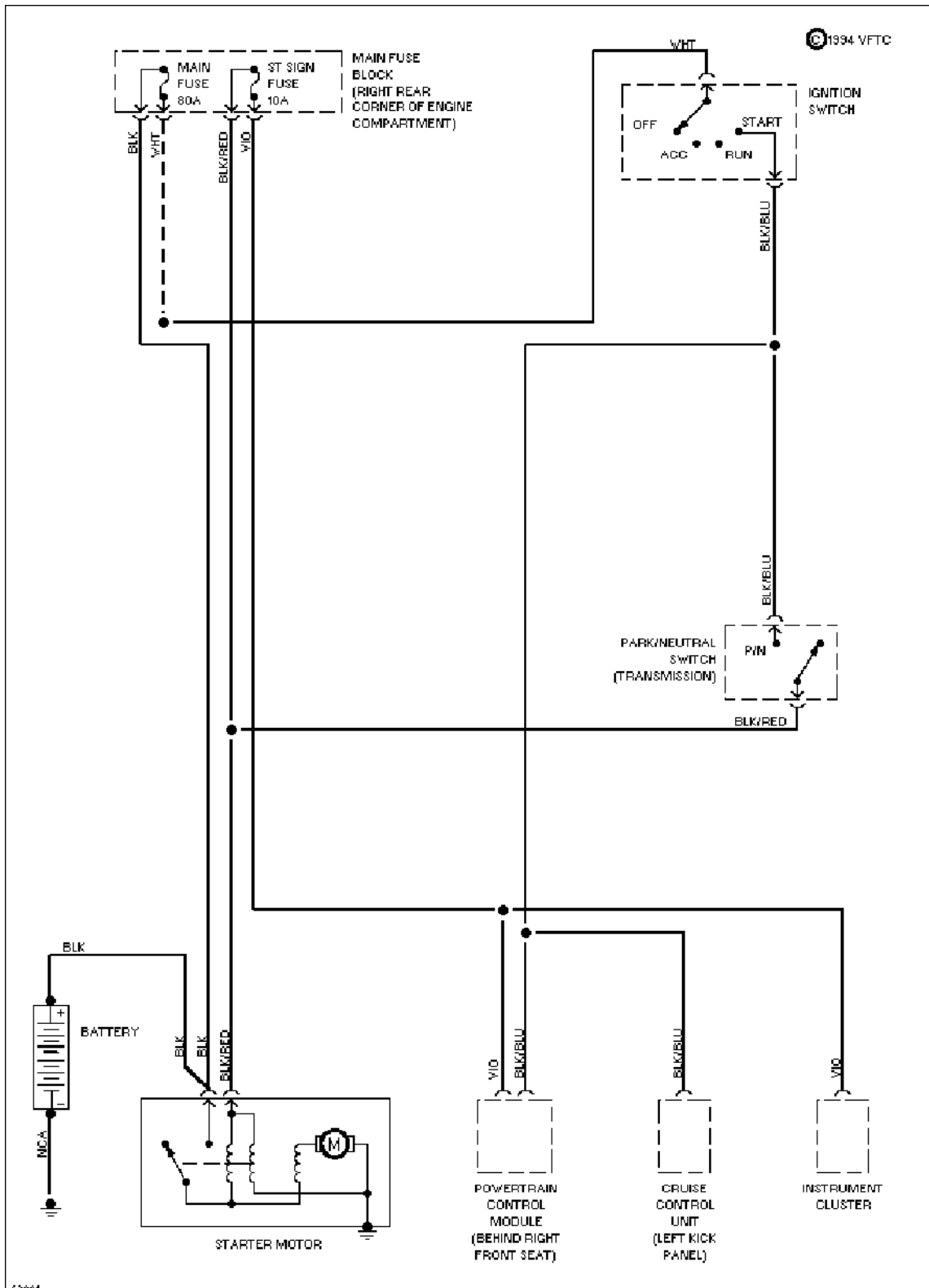

Starting Circuit, A/T

# SYSTEM WIRING DIAGRAMS

Article Text (p. 29)

1994 Mazda Miata

For Yorba Linda Miata

Copyright © 1998 Mitchell Repair Information Company, LLC

Saturday, May 10, 2003 11:28AM

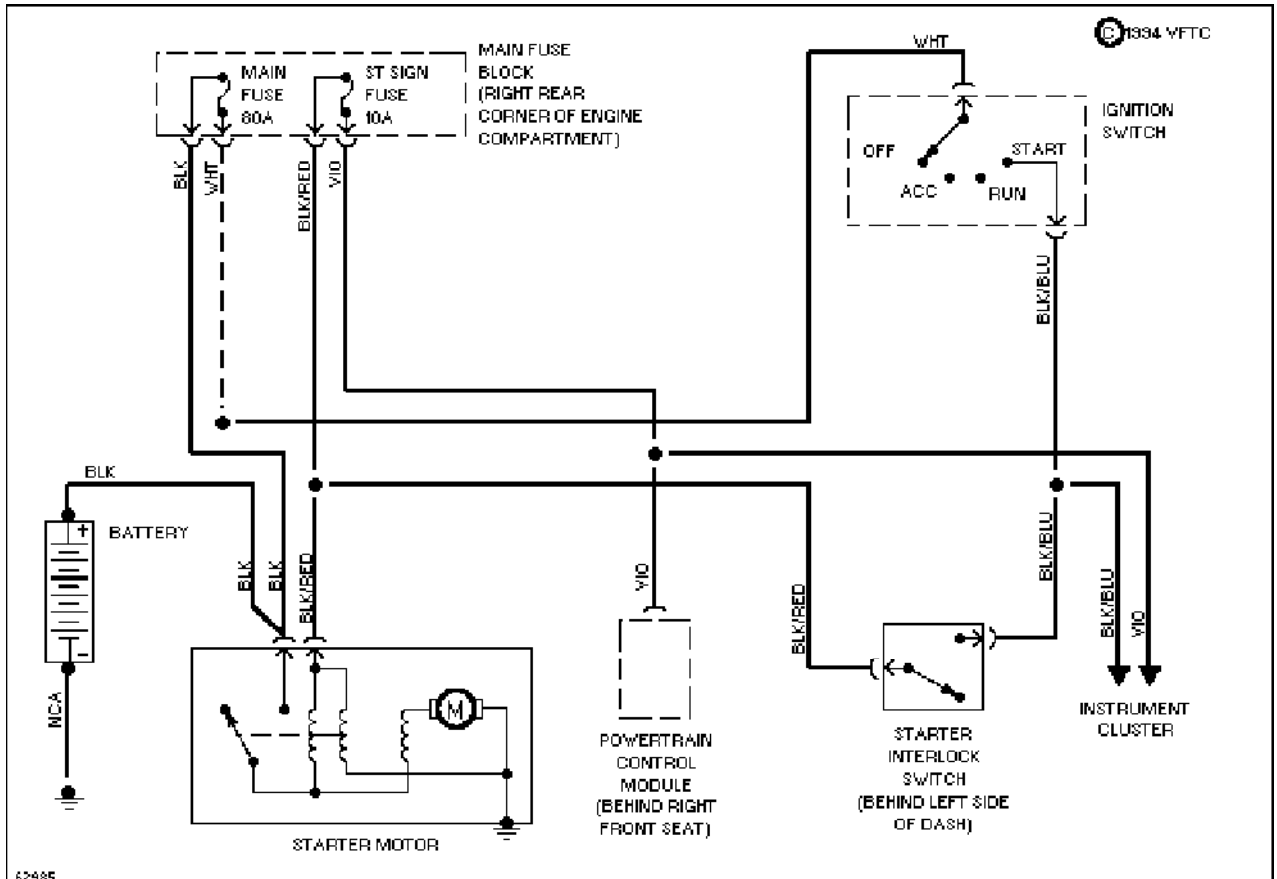

## SUPPLEMENTAL RESTRAINTS

# SYSTEM WIRING DIAGRAMS

Article Text (p. 30)

1994 Mazda Miata

For Yorba Linda Miata

Copyright © 1998 Mitchell Repair Information Company, LLC

Saturday, May 10, 2003 11:28AM

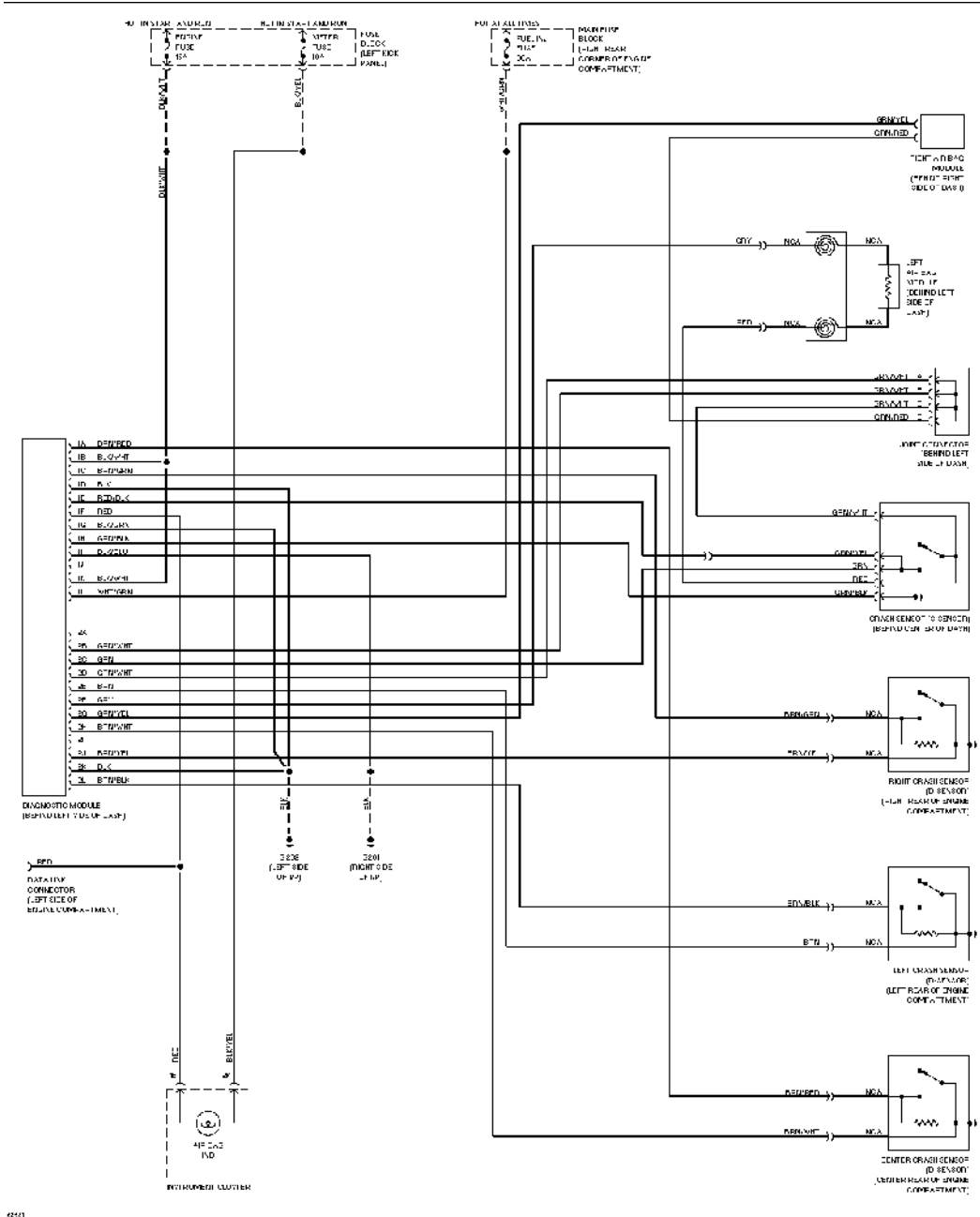

Supplemental Restraint Circuit

## TRANSMISSION

**SYSTEM WIRING DIAGRAMS**  
**Article Text (p. 31)**  
 1994 Mazda Miata  
 For Yorba Linda Miata  
 Copyright © 1998 Mitchell Repair Information Company, LLC  
 Saturday, May 10, 2003 11:28AM

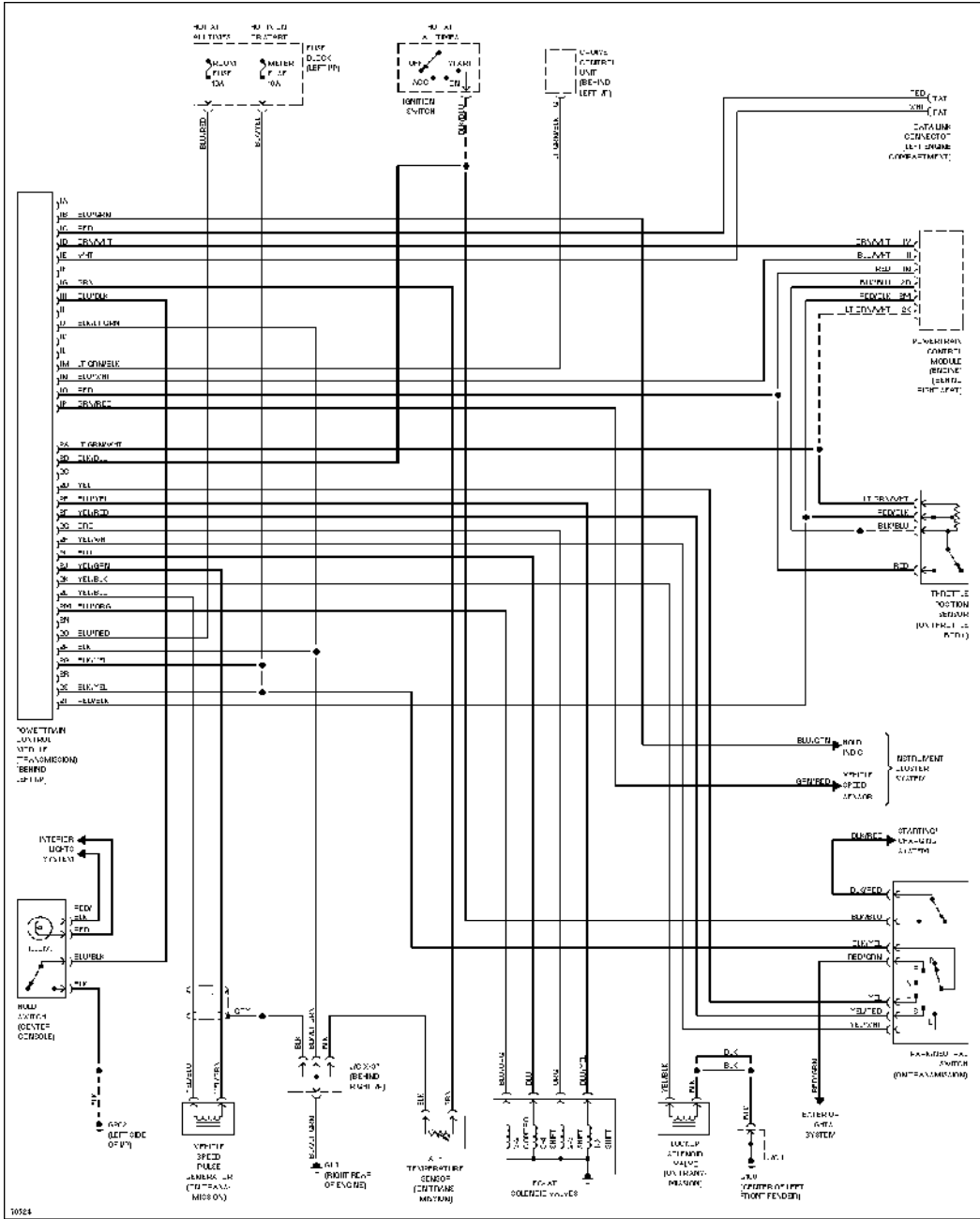

Transmission Circuit

**WARNING SYSTEMS**

# SYSTEM WIRING DIAGRAMS

Article Text (p. 32)

1994 Mazda Miata

For Yorba Linda Miata

Copyright © 1998 Mitchell Repair Information Company, LLC

Saturday, May 10, 2003 11:28AM

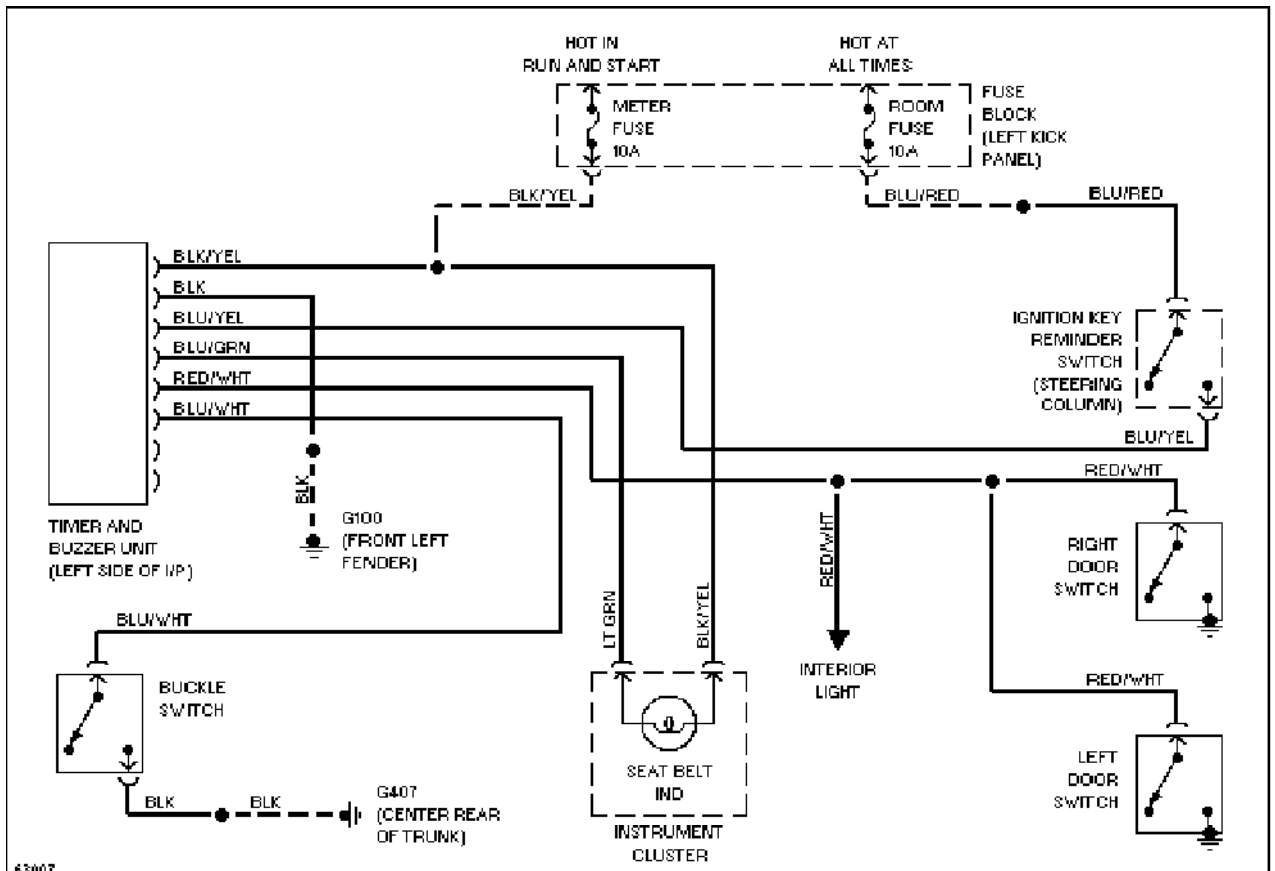

Warning System Circuits

## WIPER/WASHER

# SYSTEM WIRING DIAGRAMS

Article Text (p. 33)

1994 Mazda Miata

For Yorba Linda Miata

Copyright © 1998 Mitchell Repair Information Company, LLC

Saturday, May 10, 2003 11:28AM

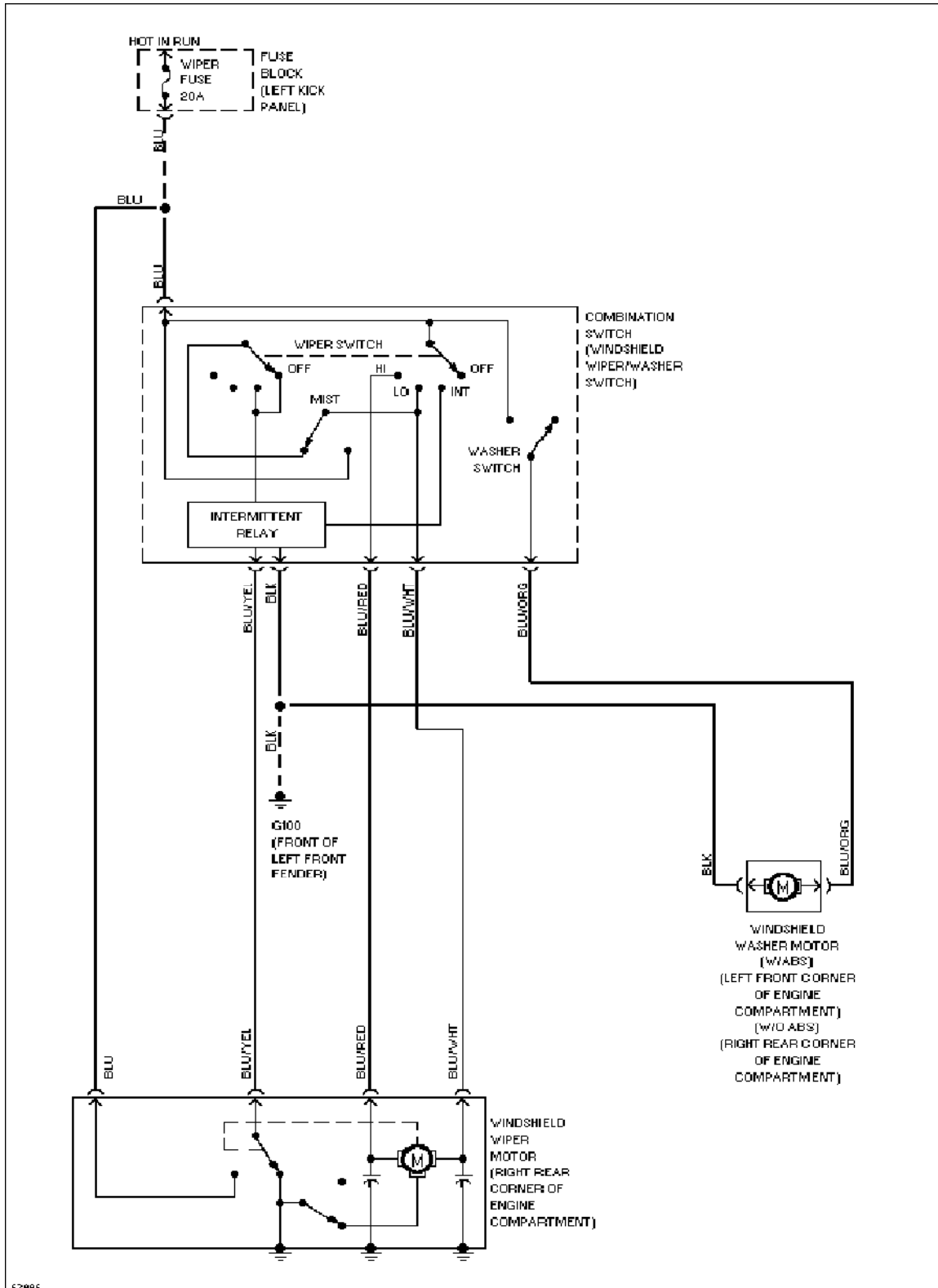

Wiper/Washer Circuit

END OF ARTICLE